

# PATTERN BOOK



**PINTO WORLD CHAMPIONSHIP SHOW®**  
**JUNE 10-22, 2024**  
**BUILT FORD TOUGH LIVESTOCK COMPLEX**  
**TULSA, OKLAHOMA**



# TABLE OF CONTENTS

---

|                                    |       |
|------------------------------------|-------|
| Bareback English Equitation .....  | 20    |
| Bareback Western Horsemanship..... | 27-28 |
| English Equitation .....           | 14-19 |
| English Showmanship.....           | 2-7   |
| Equitation Over Fences .....       | 40    |
| Halter.....                        | 58    |
| Hunter Over Fences In-Hand .....   | 43    |
| Hunter Hack.....                   | 38    |
| Jumping.....                       | 41    |
| Jumping In-Hand.....               | 42    |
| Obstacle Driving.....              | 56    |
| Ranch Horsemanship.....            | 29-30 |
| Ranch Reining.. ..                 | 34    |
| Ranch Riding.....                  | 31-33 |
| Ranch Trail.....                   | 54-55 |
| Reinsmanship.....                  | 57    |
| Trail.....                         | 46-53 |
| Trail in Hand.....                 | 44-45 |
| Western Horsemanship .....         | 21-26 |
| Western Riding.....                | 35-37 |
| Western/Ranch Showmanship .....    | 8-13  |
| Working Hunter Over Fences .....   | 39    |

**Please note:** Many PTHA Equitation, Horsemanship and Showmanship classes have a *Preliminary* and *Final* pattern. The *Final* pattern will ONLY be used if there are more than 25 entries and the class is split according to the Split Classes rule in the 2024 Pinto World Championship Premium Book. In this case, only the recalls will perform the *Final* pattern. The finals class will run after the other age divisions of the same class. If the class is not split, ONLY the *Preliminary* pattern will be used.

# English Showmanship

## Classes

### PRELIM

- 4 - AM Jr Solid
- 5 - AM Sr/El Solid
- 11 - Amateur Novice
- 20 - YA Walk/Trot 11-18

### FINALS

- 22 - YA Walk/Trot 10&U
- 23 - YA Walk/Trot 10 & U Solid
- 629 - AM Pony/Mini/B Mini
- 630 - YA Pony/Mini/B Mini

## Instructions

1. Trot, stop
2. Back until hip is even with Judge
3. Execute turn until facing Judge
4. Walk to Judge, stop
5. Set up
6. Inspection
7. When dismissed, execute  $\frac{3}{4}$  turn
8. Trot, stop
9. Walk to exit

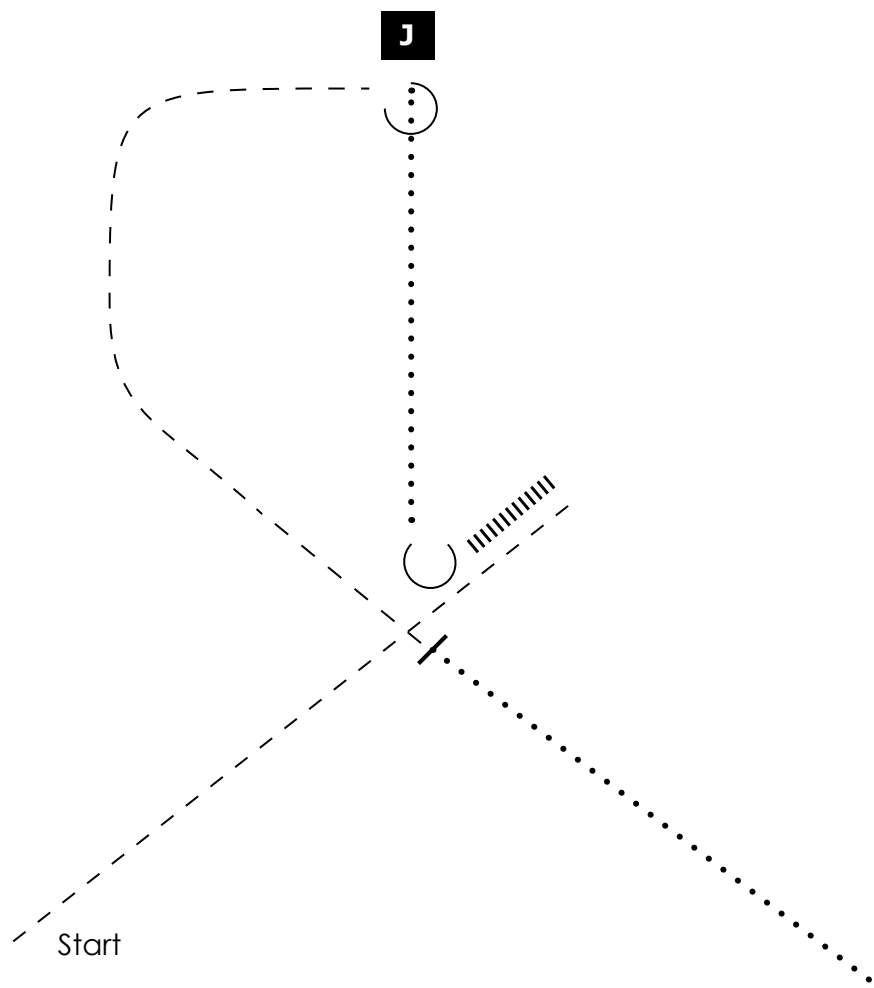

Walk . . . . .

Trot - - - -

Back |||||

Judge



# English Showmanship

## Instructions

1. Walk
2. Trot to Judge, stop
3. Set up
4. Inspection
5. When dismissed, execute  $\frac{1}{4}$  turn
6. Back one horse length
7. Execute  $\frac{1}{2}$  turn
8. Walk, stop
9. Execute 1 turn
10. Trot to exit

## Classes

*PRELIM*  
10 - AM Elite  
14 - YA JR

*FINALS*  
4 - AM Jr Solid  
5 - AM Sr/El Solid  
11 - Amateur Novice  
16 - YA Jr Novice  
17 - YA Sr Novice  
18 - YA Jr Solid  
19 - YA Sr Solid  
20 - YA Walk/Trot 11-18  
21 - YA Walk/Trot 11-18 Solid

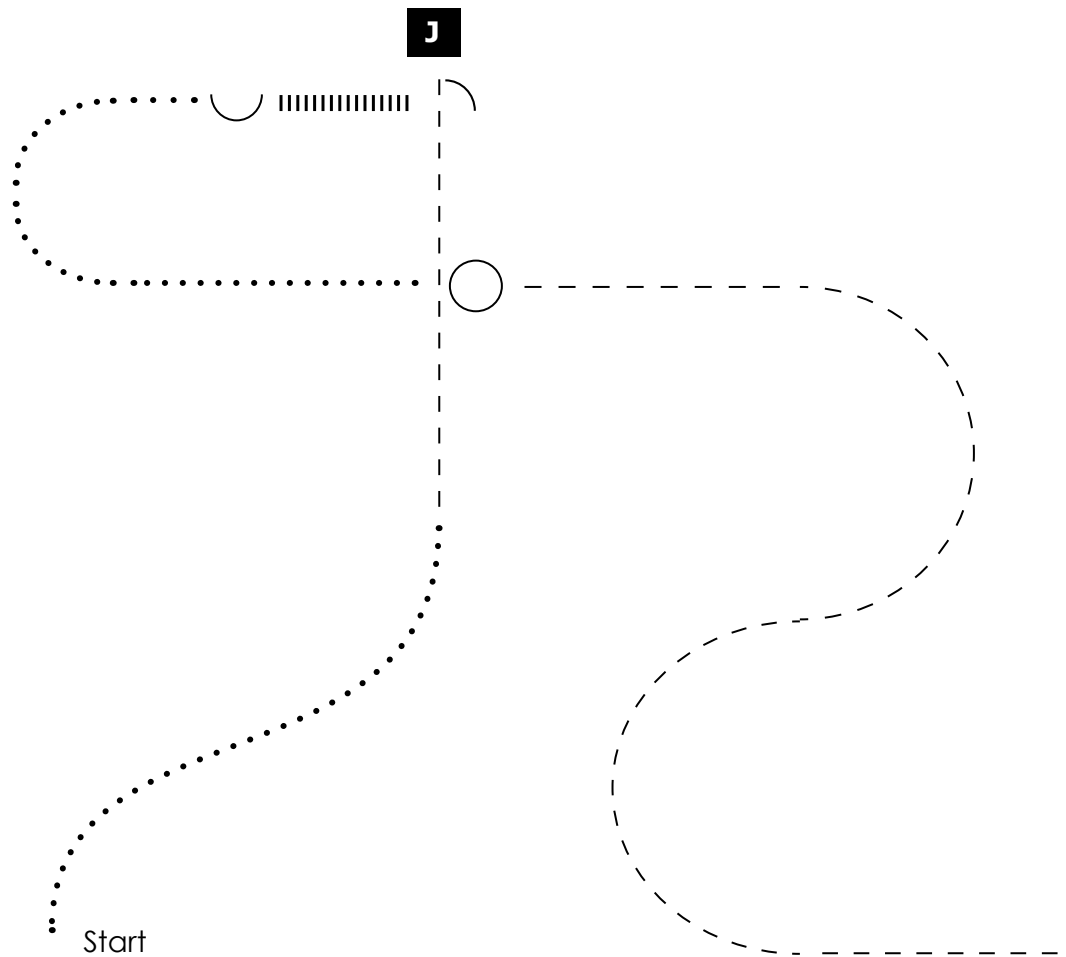

Walk .....

Trot - - - -

Back |||||

Judge

**J**

# English Showmanship

## Classes

### PRELIM

- 8 - AM JR Horse
- 9 - AM SR Horse
- 15 - YA SR Horse

### FINALS

- 10 - AM Elite Horse
- 14 - YA JR Horse

## Instructions

1. Trot, stop when hip is even with Judge
2. Execute  $\frac{1}{4}$  turn
3. Set up
4. Inspection
5. When dismissed, back one horse length
6. Execute 1 turn
7. Trot circle, stop
8. Execute  $\frac{1}{2}$  turn
9. Walk
10. Trot to exit

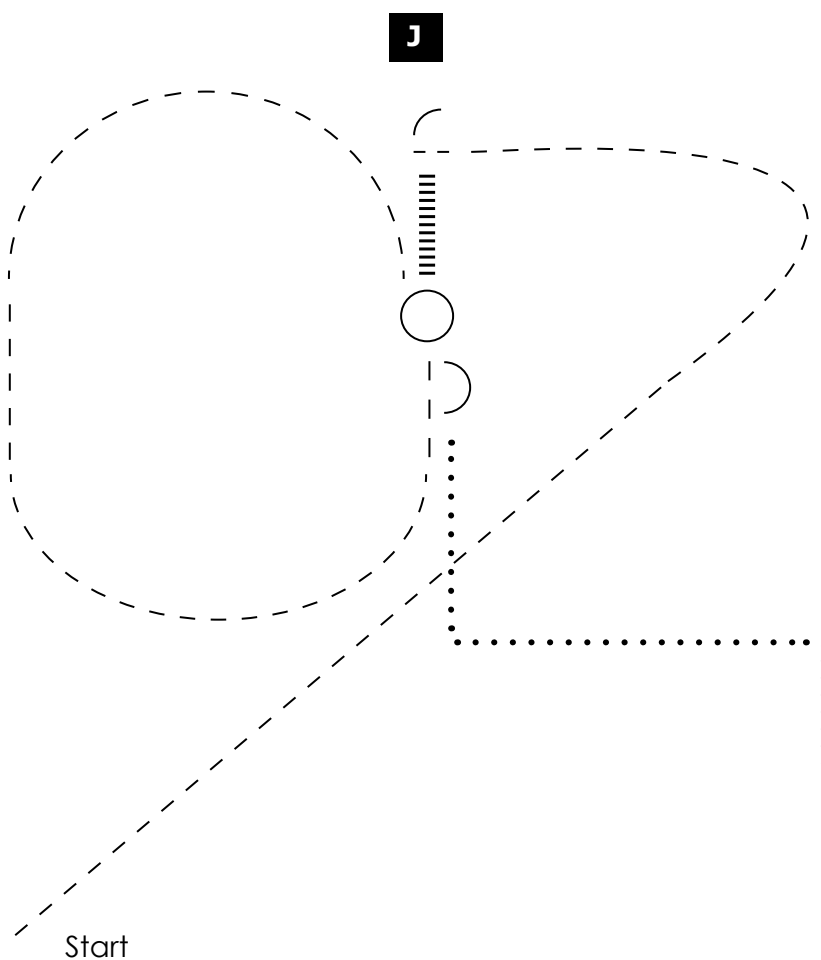

Walk .....

Trot - - - -

Back |||||||||

Judge



# English Showmanship

## Instructions

1. Trot
2. Walk to Judge, stop
3. Set up
4. Inspection
5. When dismissed, back one horse length, execute  $\frac{1}{4}$  turn, back one horse length, execute  $\frac{1}{4}$  turn, back one horse length
6. Trot
7. Walk
8. Trot
9. Extended trot

## Classes

- FINALS  
8 - AM JR Horse  
9 - AM SR Horse  
15 - YA SR Horse

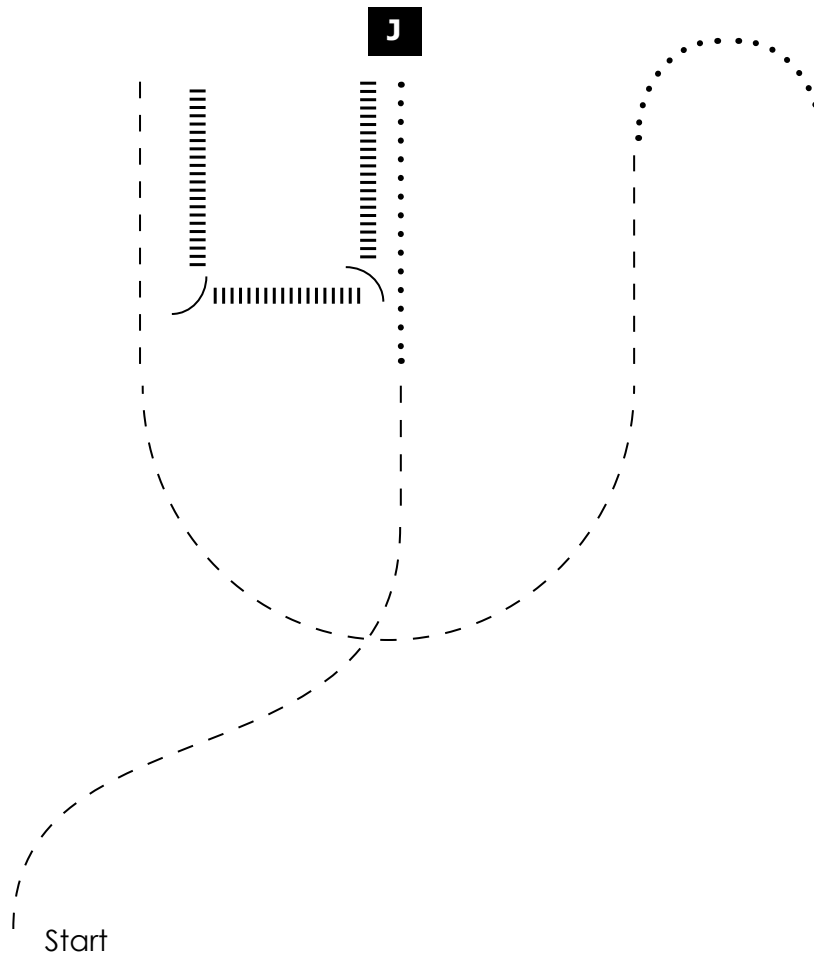

Walk .....

Trot - - - -

Extended Trot — — — —

Back |||||

Judge



# English Showmanship

## Classes

PRELIM

- 1 - AM Jr Walk/Trot
- 2 - AM Sr Walk/Trot
- 3 - AM Elite Walk/Trot
- 6 - AM Jr Walk/Trot Solid Horse
- 7 - AM Sr/Elite Walk/Trot Solid Horse

## Instructions

1. Walk, stop
2. Back until hip is even with Judge
3. Execute turn until facing Judge
4. Walk to Judge, stop
5. Set up
6. Inspection
7. When dismissed, execute  $\frac{3}{4}$  turn
8. Walk, stop
9. Walk to exit.

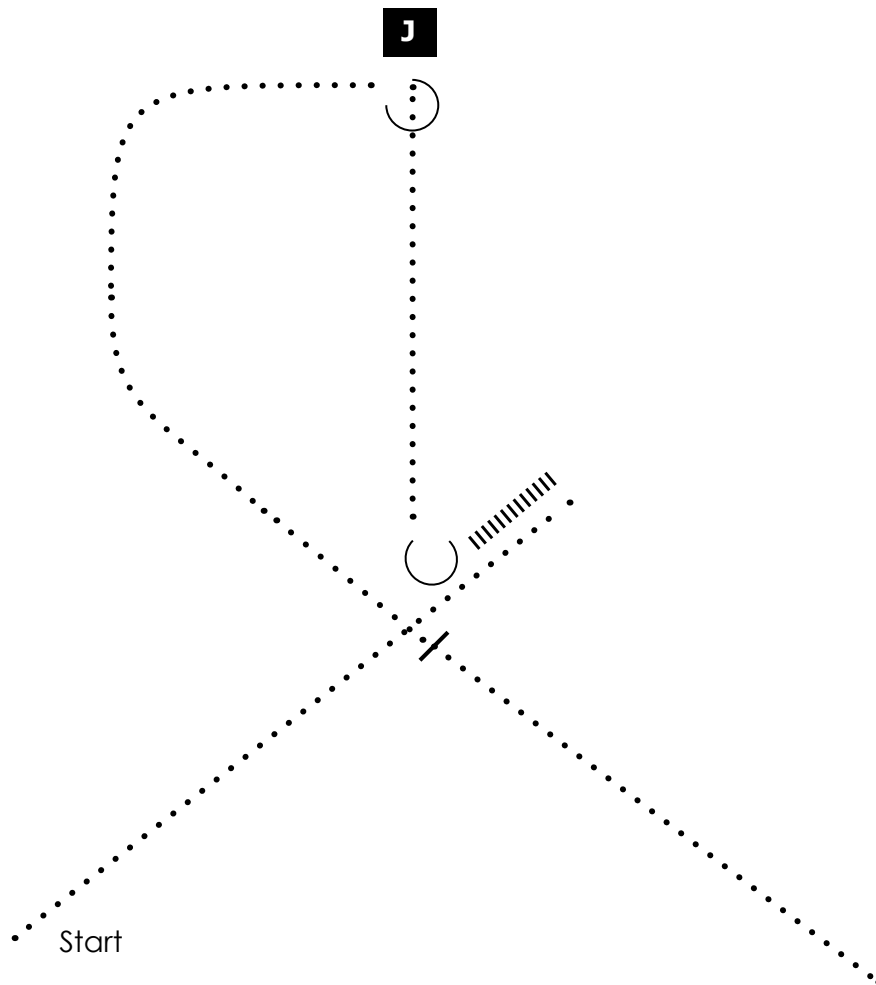

Walk    . . . . .

Back    |||||

Judge    **J**

# English Showmanship

## Instructions

1. Walk to Judge, stop
2. Set up
3. Inspection
4. When dismissed, execute  $\frac{1}{4}$  turn
5. Back one horse length
6. Execute  $\frac{1}{2}$  turn
7. Walk, stop
8. Execute 1 turn
9. Walk to exit

## Classes

### FINALS

- 1 - AM Jr Walk/Trot
- 2 - AM Sr Walk/Trot
- 3 - AM Elite Walk/Trot
- 6 - AM Jr Walk/Trot Solid Horse
- 7 - AM Sr/Elite Walk/Trot Solid Horse

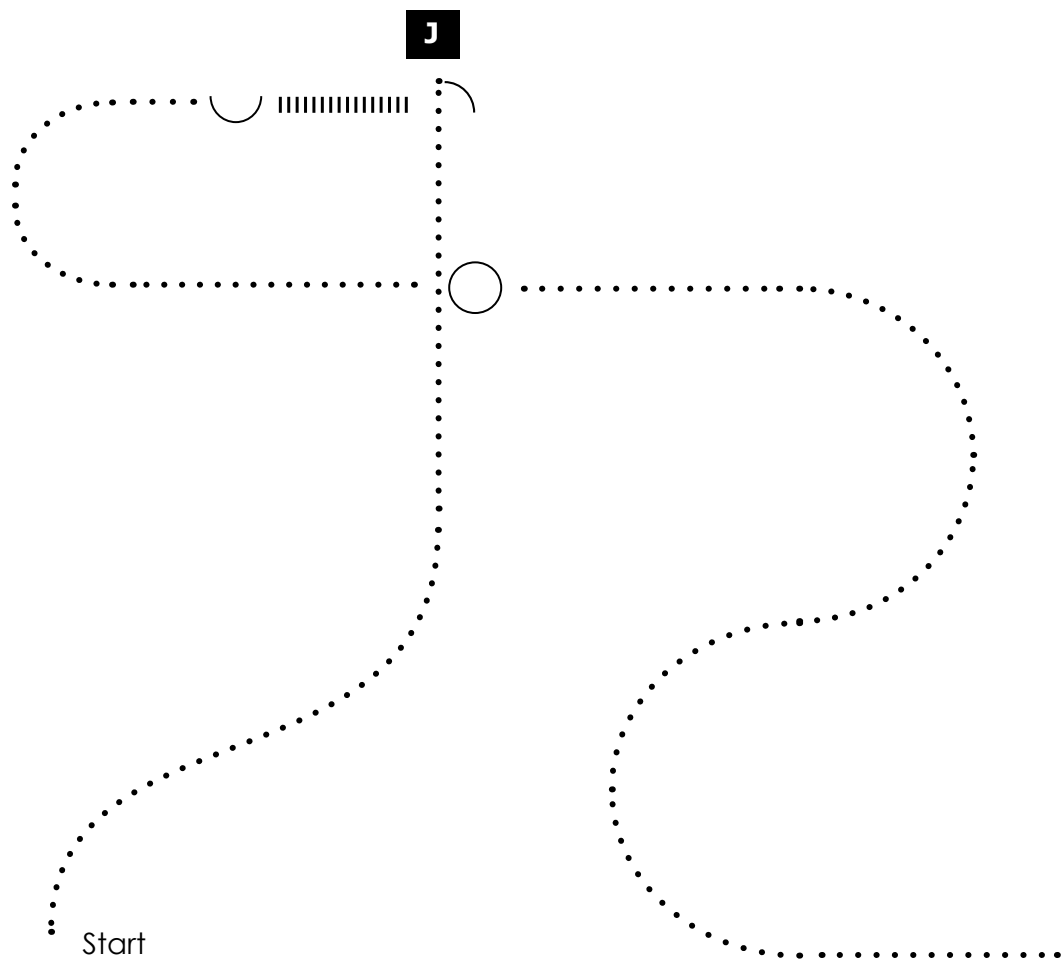



# Western/Ranch Showmanship

## Classes

### PRELIM

- 480 - YA Walk/Trot 11-18
- 481 - YA Walk/Trot 10&U
- 613 - AM Novice
- 624 - AM Novice Solid

### FINALS

- 142 - YA Ranch Walk/Trot 11-18
- 143 - YA Ranch
- 144 - YA Ranch Walk/Trot 11-18
- 145 - YA Ranch Solid
- 147 - AM Ranch
- 149 - AM Ranch Solid
- 452 - YA Walk/Trot 10&U Solid
- 453 - YA Leadline
- 454 - YA Leadline Solid
- 714 - AM Pony/Mini/B Mini
- 715 - YA Walk/Trot 10&U Mini/BMini
- 716 - YA Walk/Trot 11-18 Mini/B Mini
- 717 - YA Pony/Mini/B Mini  
11-18 Solid

## Instructions

1. Walk, stop
2. Back one horse length
3. Execute ¼ turn, trot, stop
4. Execute ¼ turn, walk to Judge, stop
5. Set up
6. Inspection
7. When dismissed, back one horse length
8. Execute ¾ turn
9. Trot, stop
10. Walk to exit

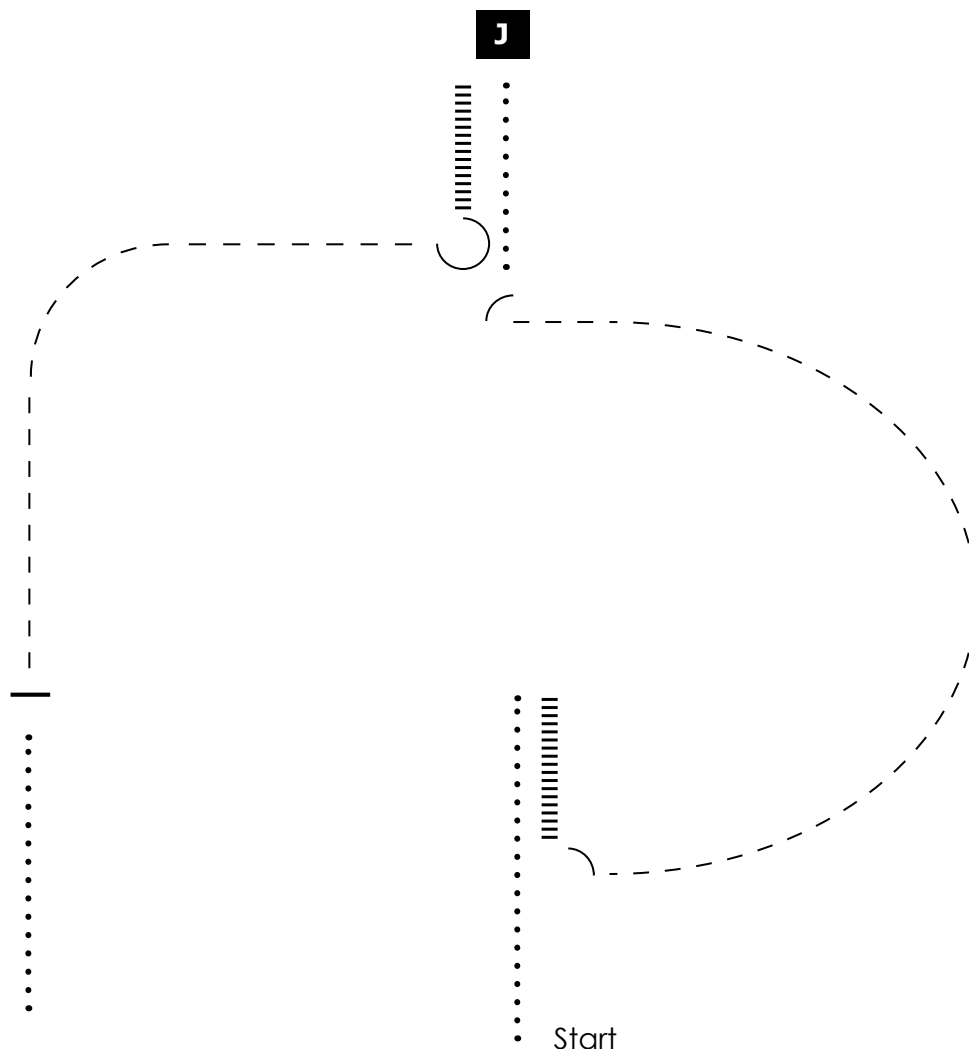

Walk ..... Trot - - - -

Back |||||

Judge





# Western Showmanship

## Classes

*PRELIM*  
477 - YA SR  
611 - AM JR  
619 - AM SR

*FINALS*  
476 - YA Jr  
612 - AM Elite  
620 - AM JR Solid  
621 - AM Sr/El Solid

## Instructions

1. Trot, stop
2. Execute 1/2 turn
3. Walk, stop
4. Back one horse length, execute 1/4 turn
5. Trot half circle, stop when hip is even with Judge, execute 1/4 turn
6. Set up
7. Inspection
8. When dismissed, back one horse length
9. Execute 3/4 turn
10. Trot, stop, walk to exit

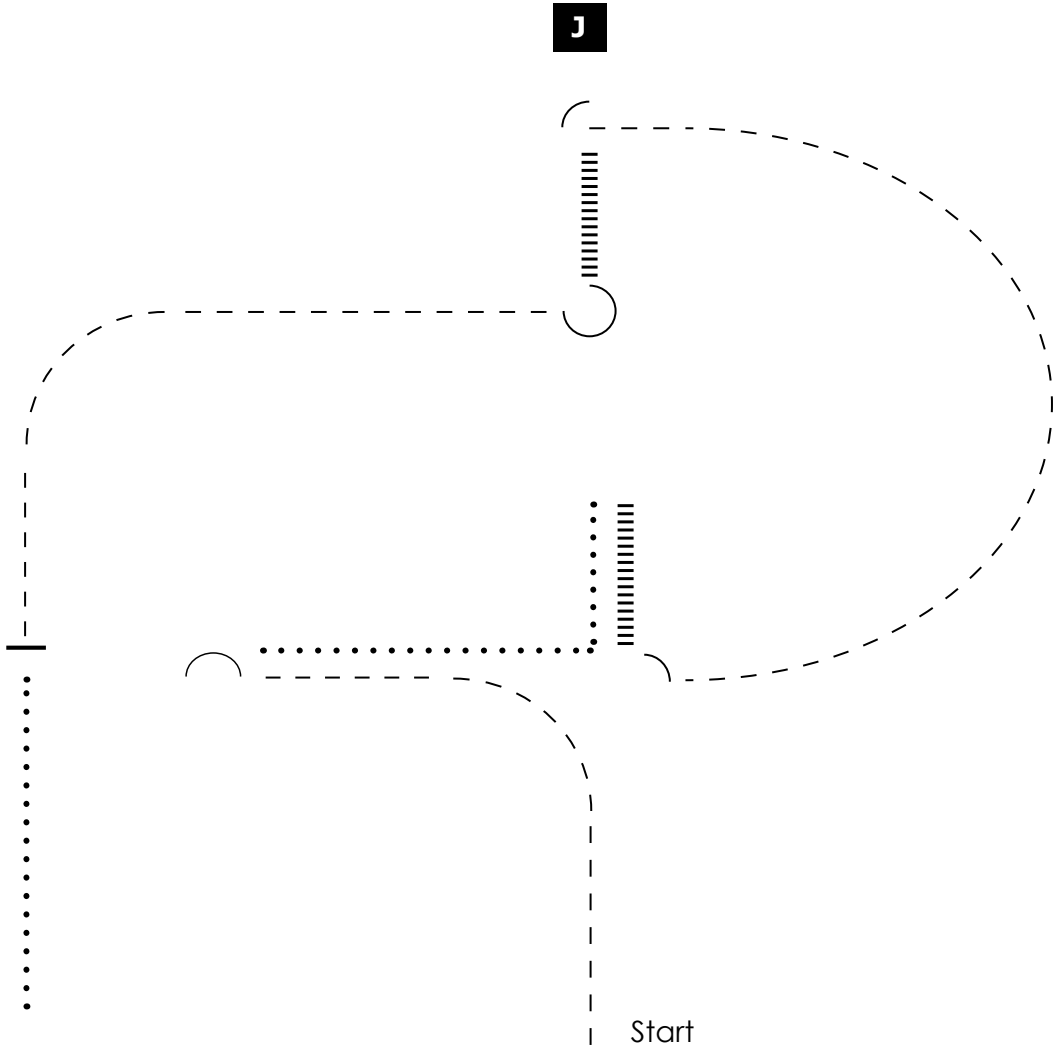

Walk ..... Trot - - - - Extended Trot — — — — Back ||||| Judge **J**

# Western Showmanship

## Instructions

1. Back two horse lengths
2. Execute 1½ turn
3. Trot to Judge, stop
4. Set up
5. Inspection
6. When dismissed, execute ½ turn
7. Trot
8. Walk
9. Trot
10. Extended trot to exit

## Classes

FINALS  
477 - YA SR  
611 - AM JR  
619 - AM SR

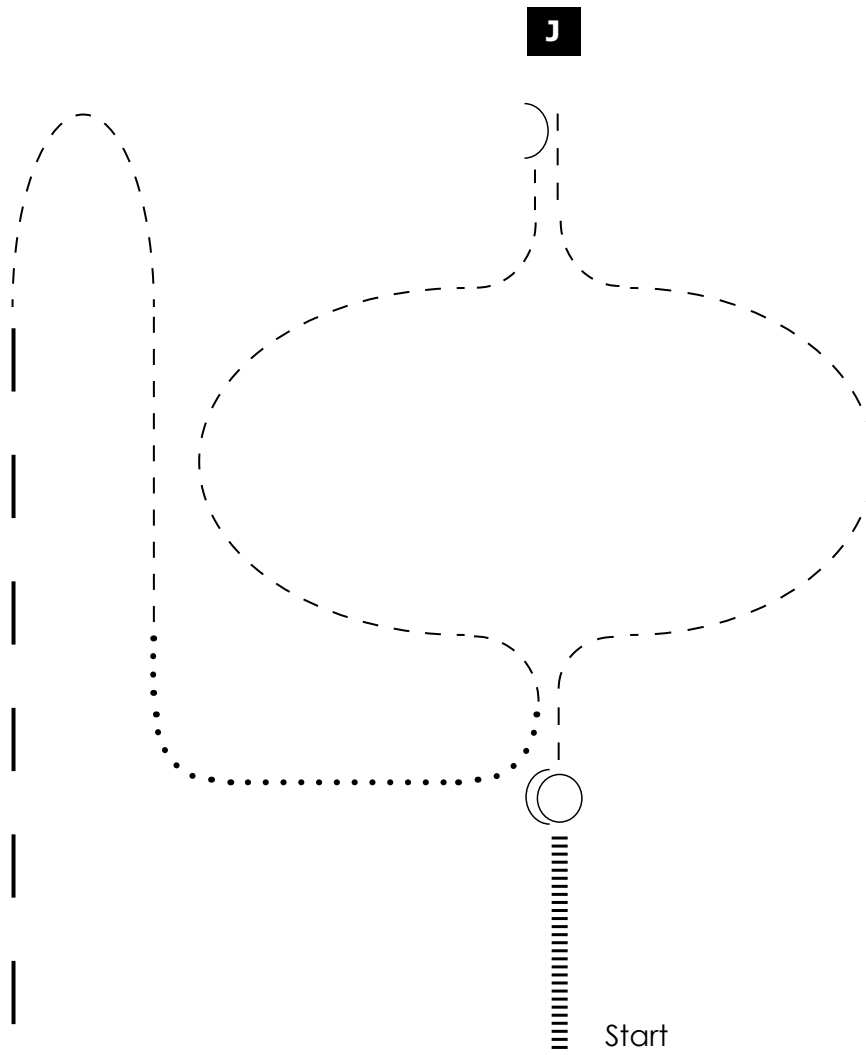

Walk .....

Trot - - - - -

Extended Trot — — — — —

Back |||||

Judge

J

# Western/Ranch Showmanship

## Classes

### PRELIM

622 - AM Jr Walk/Trot  
Solid

623 - AM Sr/El Walk/Trot  
Solid

676 - AM Jr Walk/Trot

677 - AM Sr Walk/Trot

678 - AM Elite Walk/Trot

### FINALS

146 - AM Ranch Walk/Trot

148 - AM Ranch Walk/Trot Solid

## Instructions

1. Walk, stop, back one horse length
2. Execute ¼ turn
3. Walk half circle, stop when hip is even with Judge
4. Execute ¼ turn
5. Walk to Judge, stop
6. Set up
7. Inspection
8. Back one horse length
9. Execute ¾ turn
10. Walk, stop, walk

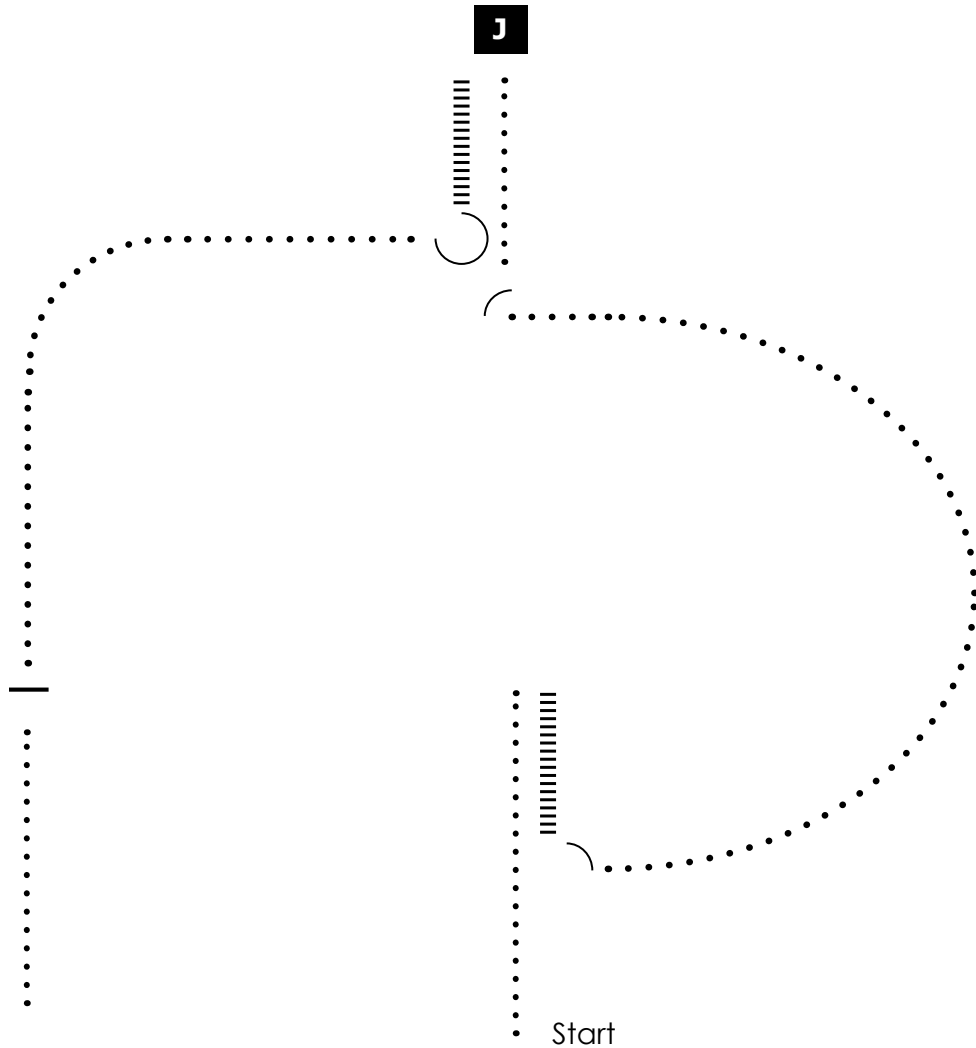

Walk .....

Back |||||

Judge **J**

# Western Showmanship

## Instructions

1. Back two horse lengths
2. Execute 1½ turn
3. Walk to Judge, stop
4. Set up
5. Inspection
6. Execute ½ turn
7. Walk to exit.

## Classes

### FINALS

- 622 - AM Jr Walk/Trot Solid
- 623 - AM Sr/El Walk/Trot Solid
- 676 - AM Jr Walk/Trot
- 677 - AM Sr Walk/Trot
- 678- AM Elite Walk/Trot
- 713 - AM Walk/Trot Pony/Mini/B Mini

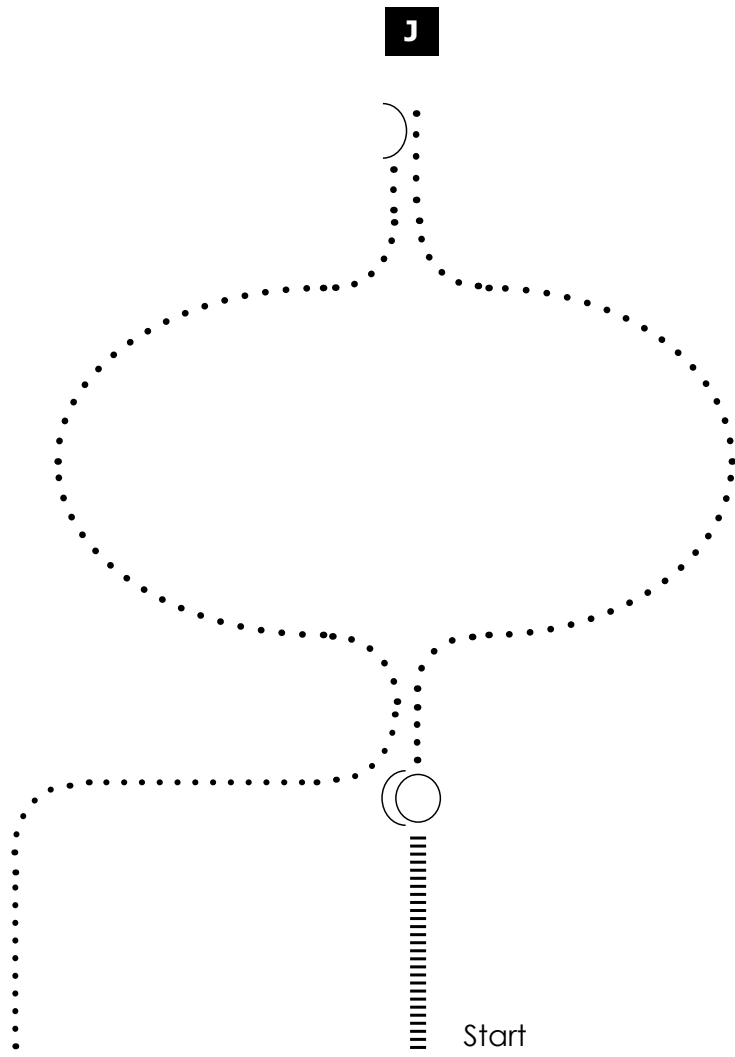

Walk . . . . .

Back |||||

Judge **J**

# English Equitation

## Classes

PRELIM

107 - AM Novice

108 - AM Novice Solid

## Instructions

1. Walk
2. Canter, left lead
3. Trot
4. Canter, right lead, stop
5. Execute  $\frac{1}{2}$  right on the forehand
6. Back one horse length
7. Sitting trot
8. Trot to exit.

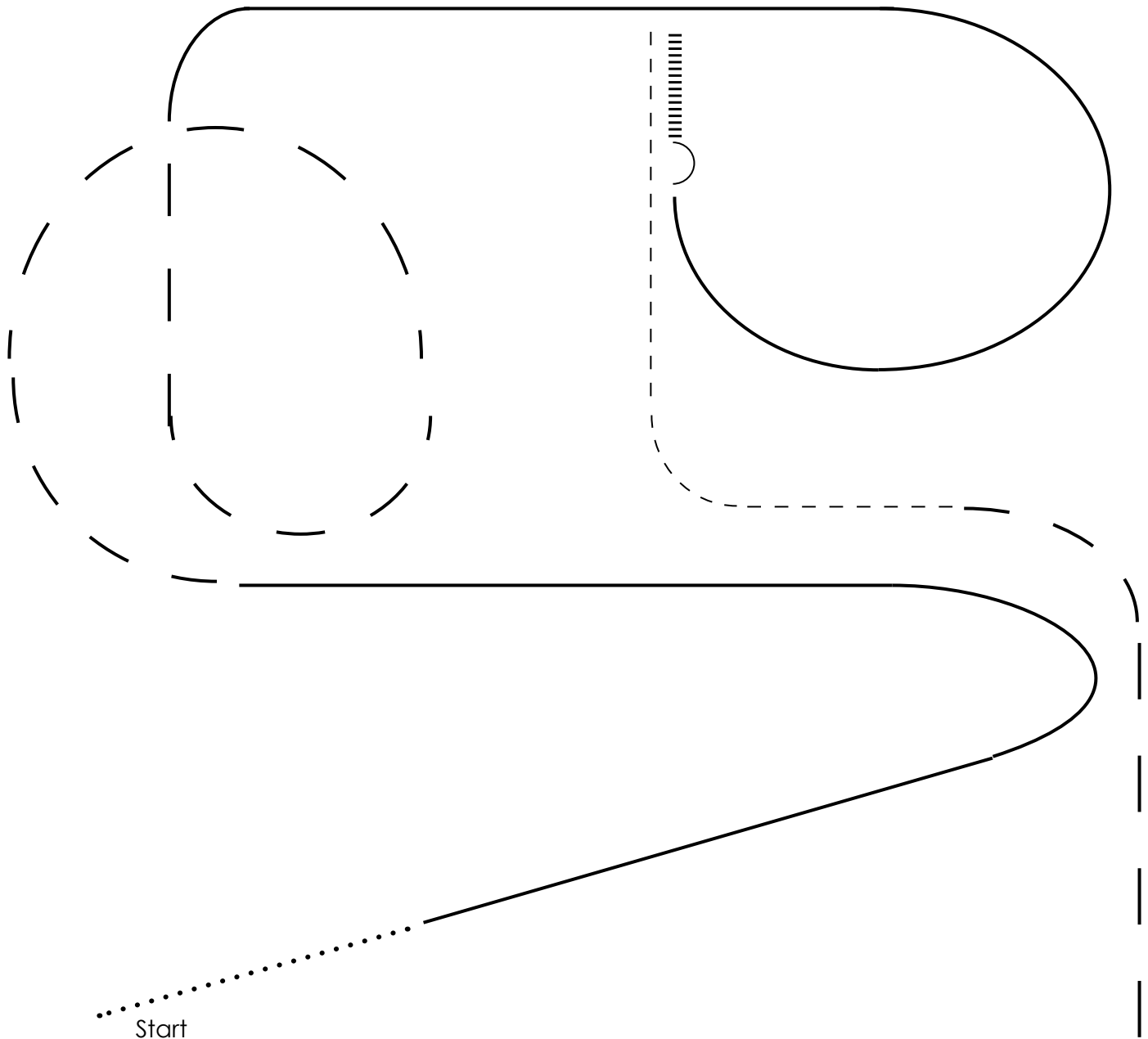

Walk    . . . . .

Sitting Trot    - - - - -

Trot    -    -

Canter    ———

Back    |||||

# English Equitation

## Instructions

1. Back one horse length
2. Execute ½ turn left on the forehand
3. Canter, right lead
4. Walk several strides
5. Canter, left lead
6. Trot
7. Sitting trot
8. Trot to exit

## Classes

### PRELIM

- 47 - YA JR
- 106 - AM Elite

### FINALS

- 49 - YA Jr Solid
- 50 - YA Sr Solid
- 121 - YA Jr Novice
- 122 - YA Sr Novice
- 56 - YA Novice Solid
- 107 - AM Novice
- 108 - AM Novice Solid
- 112 - AM JR Solid
- 113 - AM SR/EL Solid

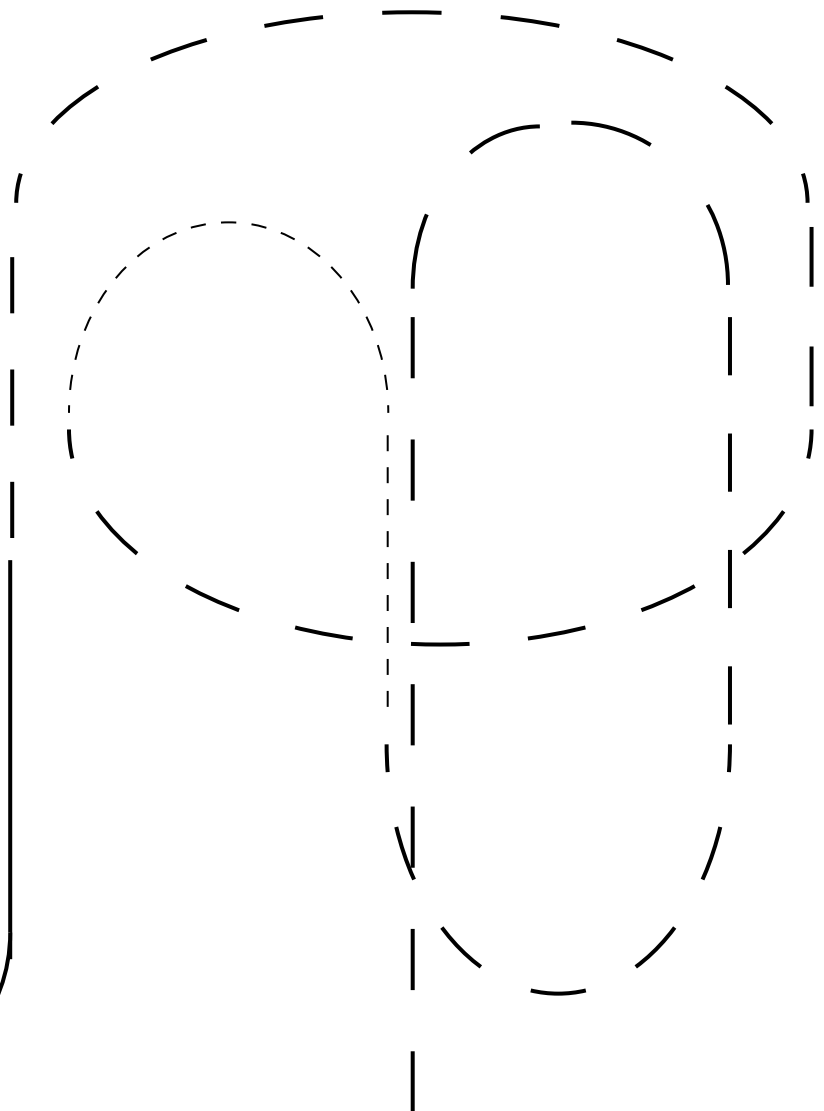
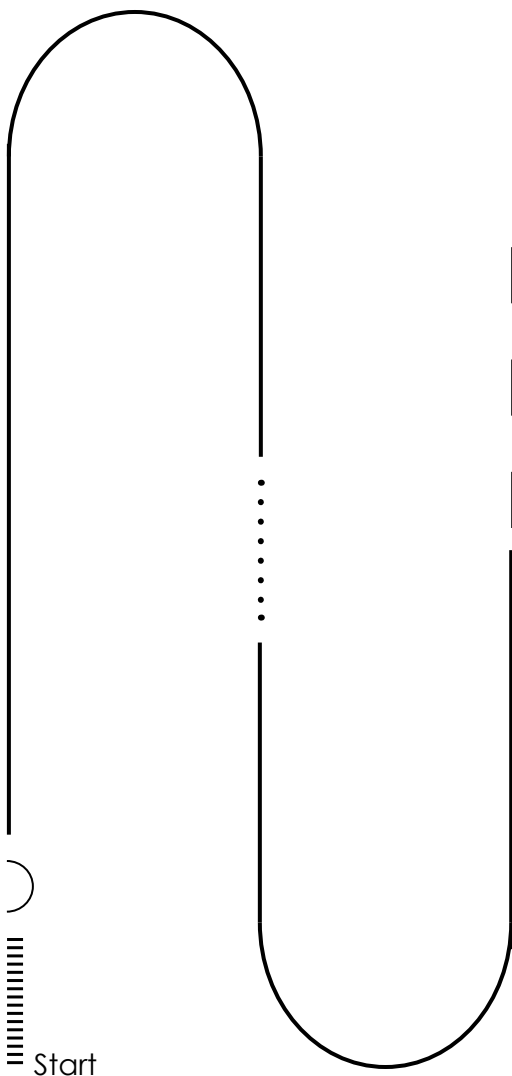

Walk    . . . . .

Sitting Trot    - - - -

Trot    — — —

Canter    —————

Back    |||||



# English Equitation

## Classes

PRELIM  
48 - YA SR  
104 - AM JR  
105 - AM SR

FINALS  
47 - YA JR  
106 - AM Elite

## Instructions

1. Execute ½ turn left on the forehand
2. Trot
3. Sitting trot
4. Canter, left lead
5. Trot
6. Canter, right lead
7. Walk
8. Canter, left lead, stop
9. Back two horse lengths
10. Walk to exit

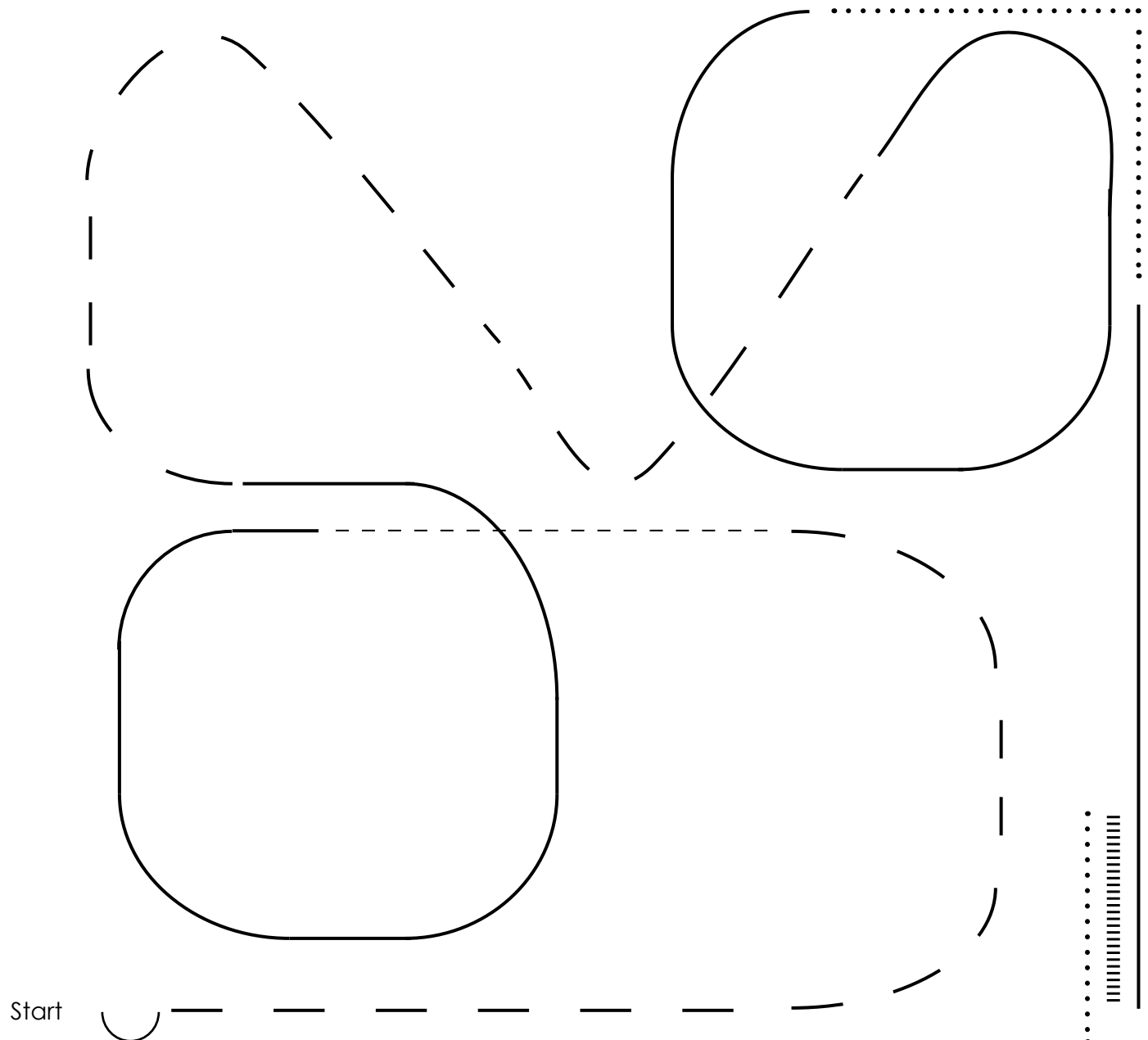

Walk ..... Sitting Trot - - - - Trot — — — Canter ———

# English Equitation

## Instructions

1. Trot
2. Canter, left lead
3. Change leads, simple or flying
4. Canter, right lead
5. Hand gallop, stop
6. Back one horse length
7. Execute ½ turn right on the forehand
8. Trot
9. Walk
10. Sitting trot to exit

## Classes

FINALS  
48 - YA SR  
104 - AM JR  
105 - AM SR

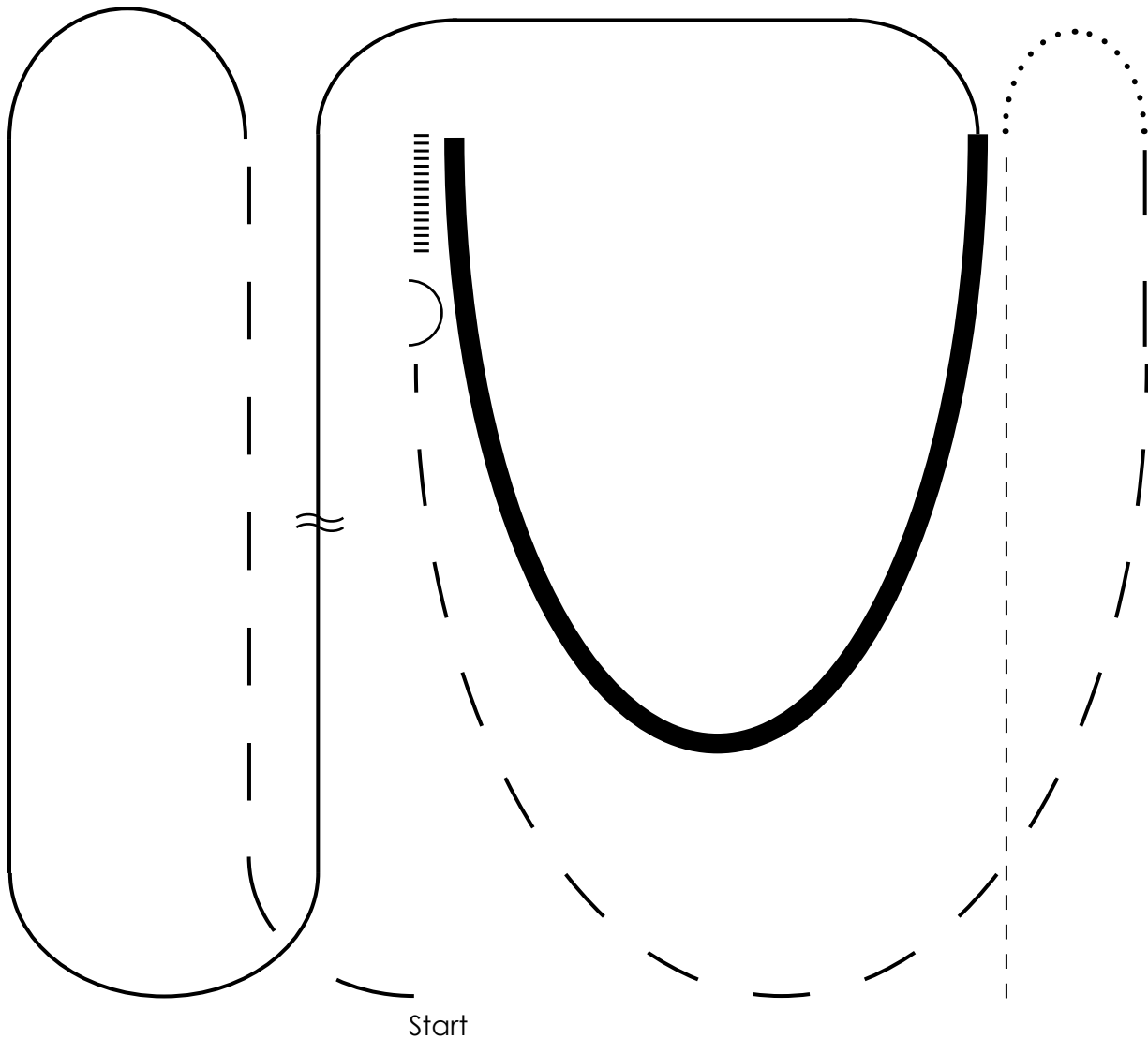

Walk .....

Sitting Trot - - - -

Trot — — — Canter ————

Back |||||

Change Leads ))

Hand Gallop —————

# English Equitation

## Classes

### PRELIM

- 51 - YA Walk/Trot 11-18
- 52 - YA Walk/Trot 11-18 Solid

### FINALS

- 53 - YA Leadline Walk/Trot
- 54 - YA Leadline Walk/Trot Solid
- 55 - YA Walk/Trot 10&U
- 57 - YA Walk/Trot 10&U Solid

## Instructions

1. Walk
2. Trot
3. Stop
4. Back one horse length
5. Execute ¼ turn right on the forehand
6. Sitting trot
7. Trot to exit

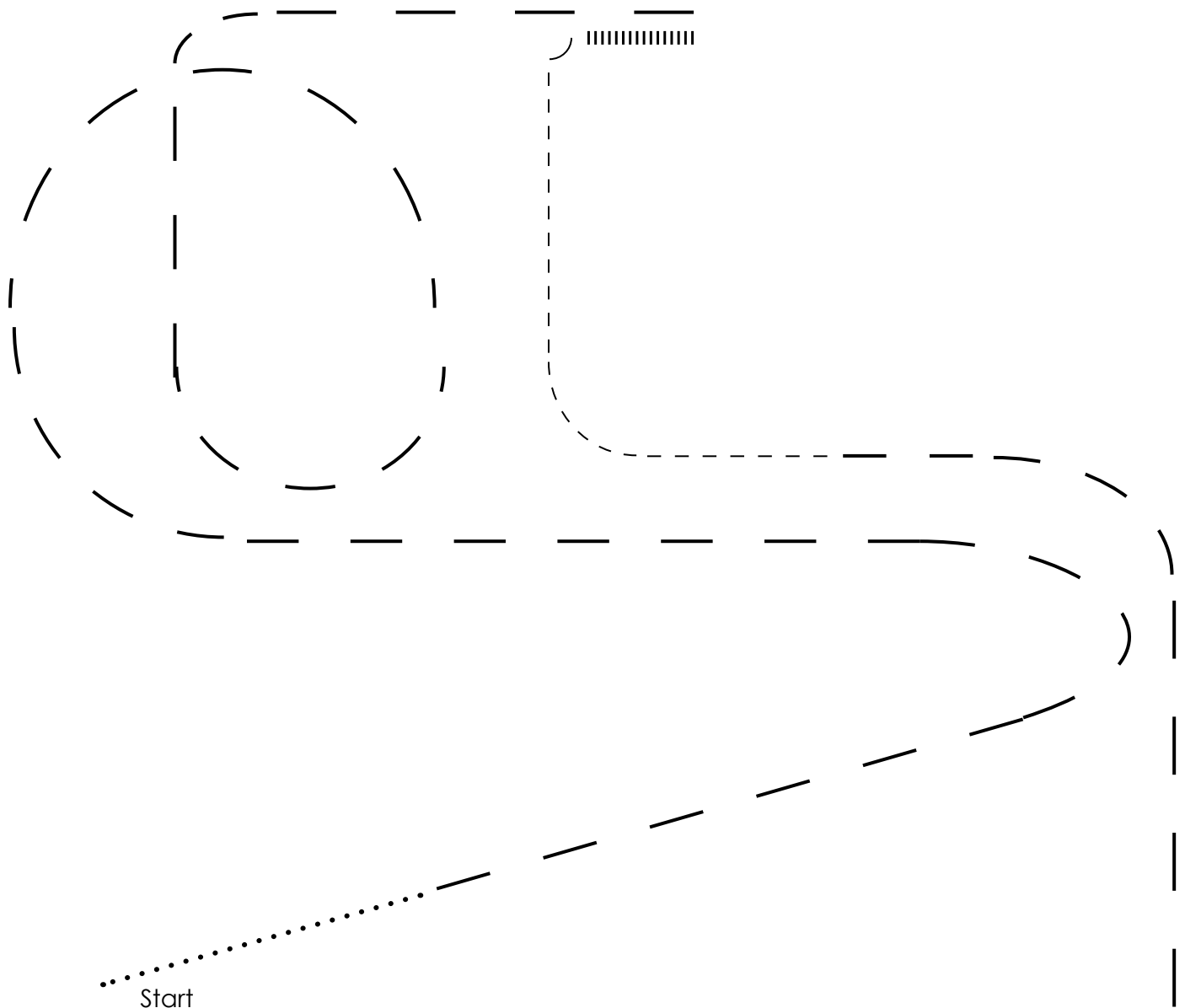

Walk ..... Sitting Trot - - - - Trot - - - - Back |||||

# English Equitation

## Instructions

1. Sitting trot
2. Walk
3. Trot, stop
4. Back one horse length
5. Execute ½ turn left on the forehand
6. Trot
7. Walk
8. Sitting trot to exit

## Classes

- FINALS*
- 51 - YA Walk/Trot 11-18
  - 52 - YA W/T 11-18 Solid
  - 109 - AM Jr Walk/Trot
  - 110 - AM Sr Walk/Trot
  - 111 - AM Elite Walk/Trot
  - 114 - AM Jr Walk/Trot Solid
  - 115 - AM Sr/El Walk/Trot Solid

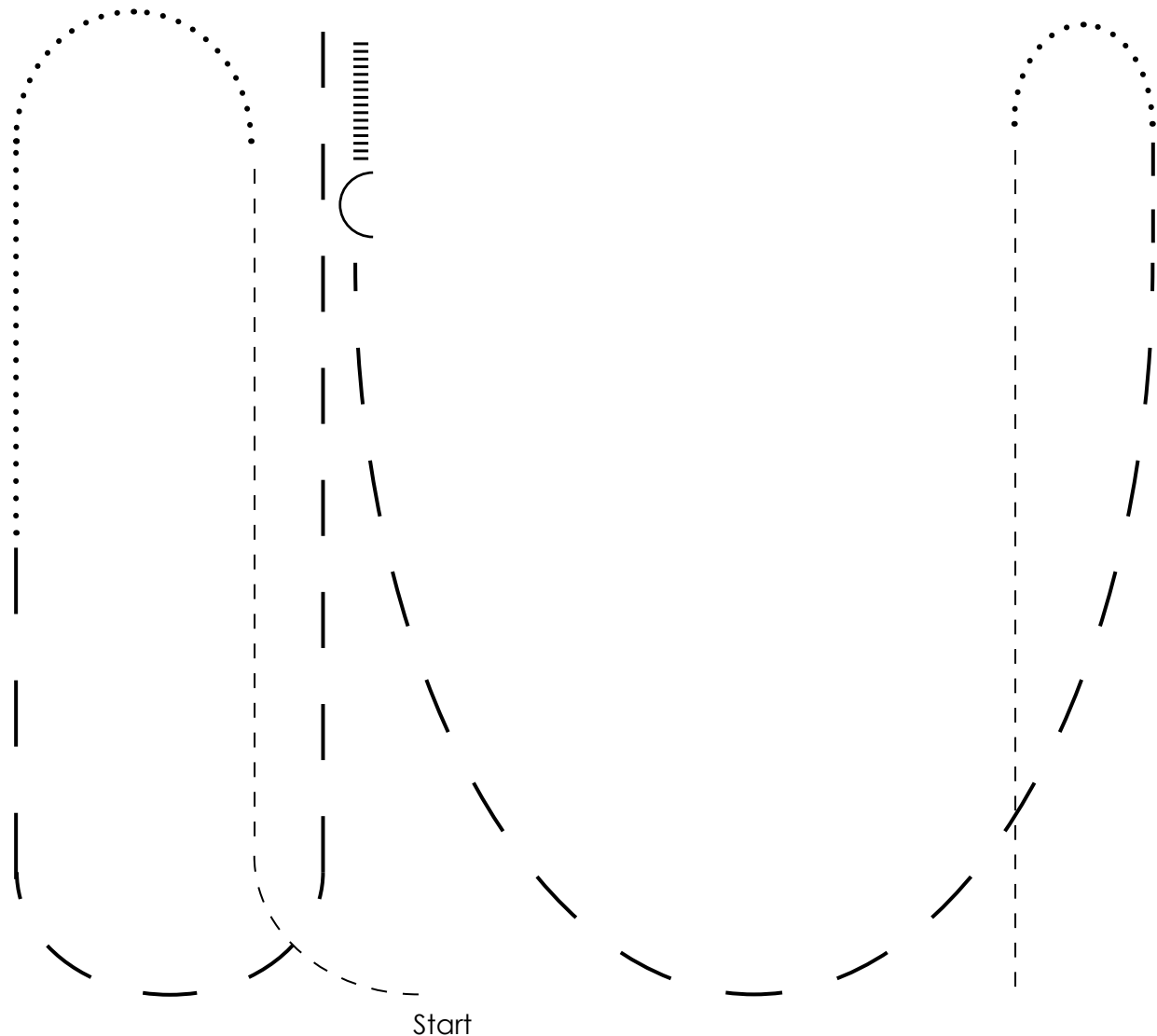

Walk ..... Sitting Trot - - - - Trot - - - - Back |||||

# Bareback English Equitation

## Classes

*FINALS*  
 12 - AM  
 13 - AM Solid  
 24 - YA Jr  
 25 - YA Sr  
 26 - YA Solid

## Instructions

1. Sitting trot
2. Stop
3. Back one horse length
4. Canter, left lead
5. Trot
6. Walk several strides
7. Canter right lead
8. Trot
9. Stop, execute  $\frac{3}{4}$  turn right on the forehand
10. Walk to exit

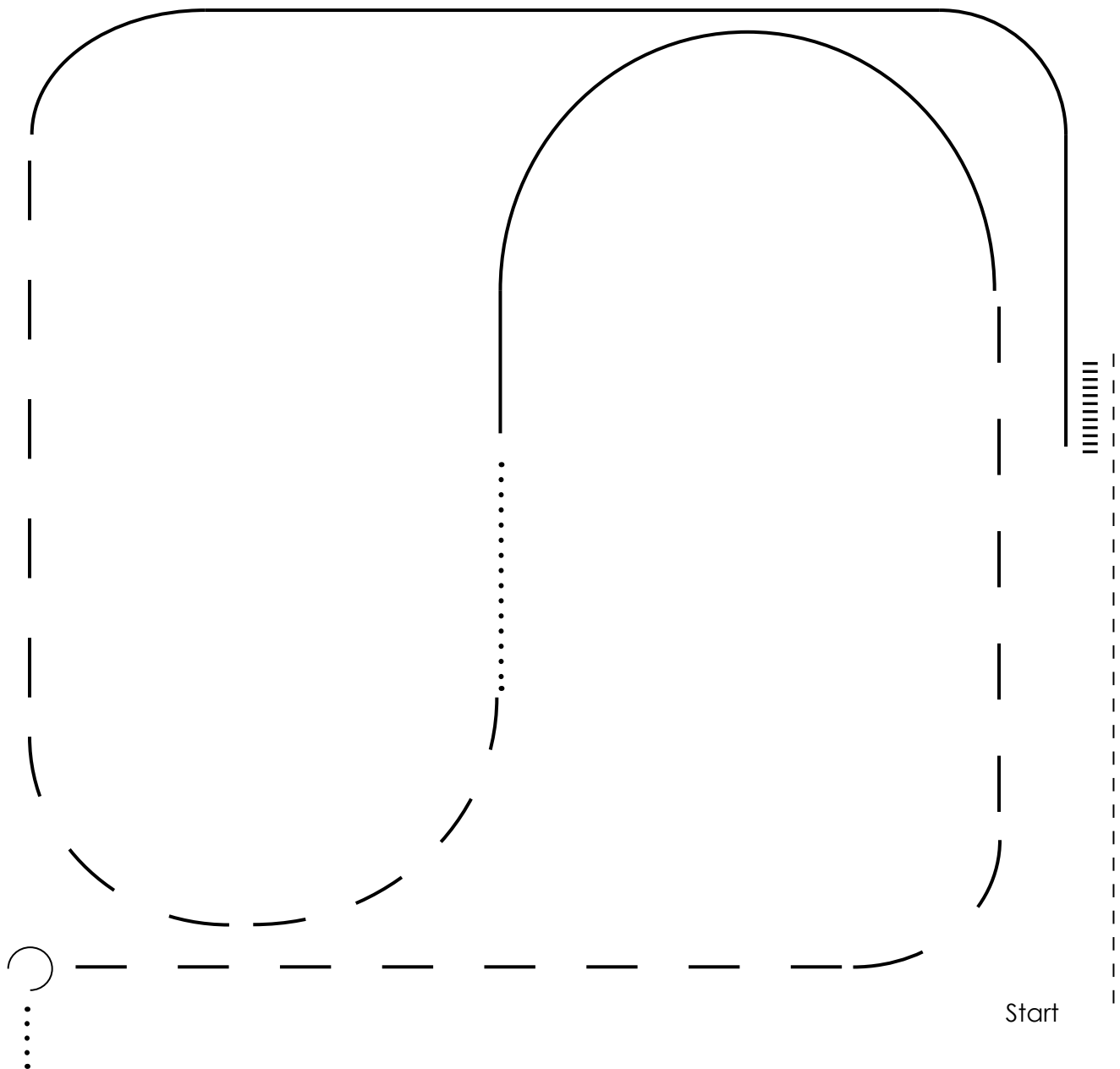

Walk .....      Sitting Trot - - - -      Trot — — — —  
 Canter —————      Back |||||

# Western Horsemanship

## Instructions

- 1. Jog
- 2. Walk
- 3. Lope, right lead, stop
- 4. Execute 1 turn left on the haunches
- 5. Extended jog
- 6. Jog circle
- 7. Lope, left lead, stop
- 8. Back one horse length

## Classes

- PRELIM
- 617 - AM Novice
- 628 - AM Novice Solid

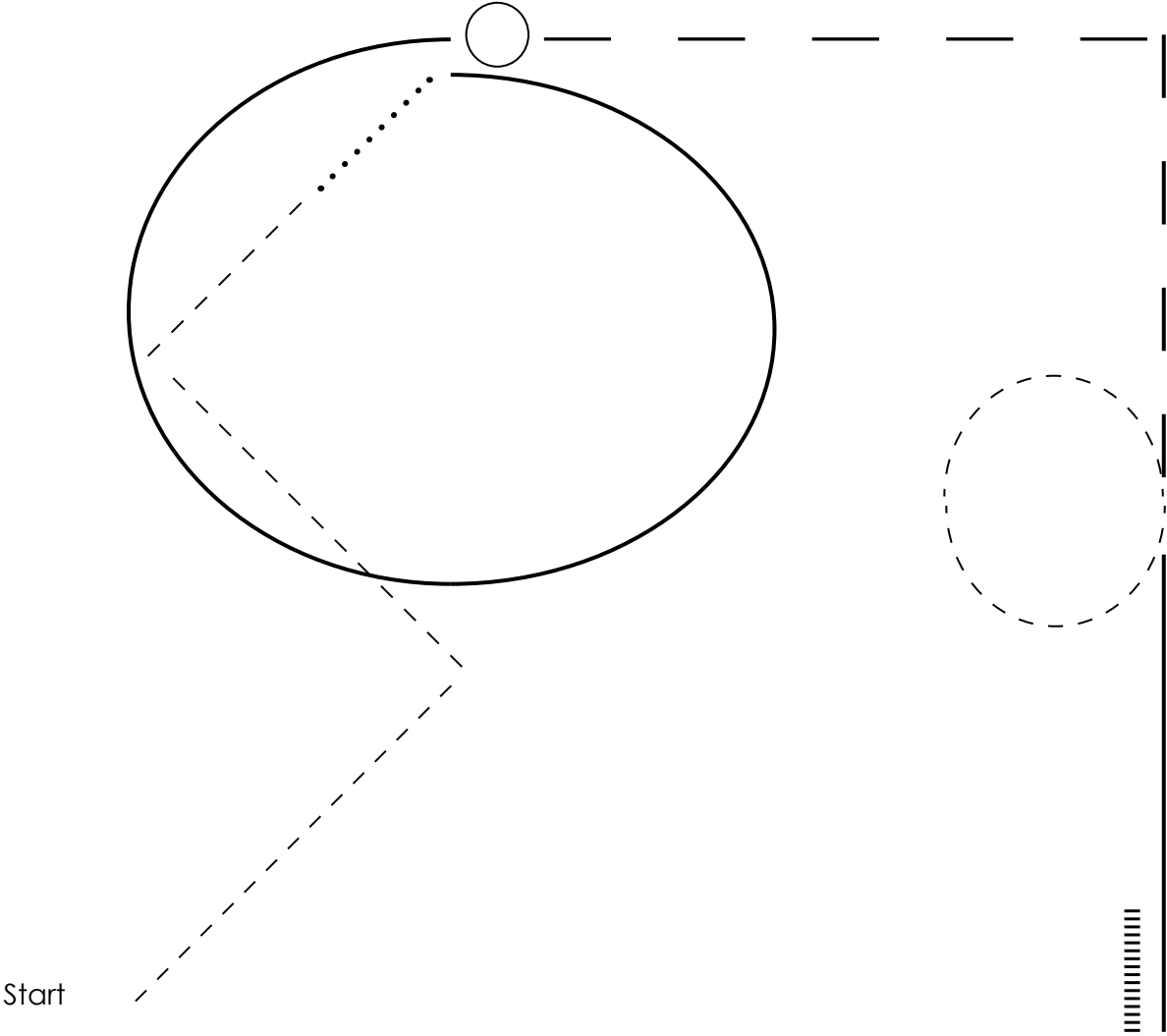

Walk ..... Jog - - - - Ext. Jog - - - -  
Lope - - - - Back |||||

# Western Horsemanship

## Classes

1. Lope, left lead, stop
2. Execute 1 turn left on the haunches
3. Back one horse length
4. Lope, right lead
5. Jog
6. Extended jog, stop
7. Execute ¼ turn right on the haunches
8. Walk
9. Jog to exit

## Instructions

### PRELIM

- 551 - YA JR
- 616 - AM Elite
- 679 - AM JR Solid
- 680 - AM Sr/El Solid

### FINALS

- 548 - YA Jr Solid
- 549 - YA Sr Solid
- 550 - YA Novice Solid
- 553 - YA Jr Novice
- 554 - YA Sr Novice
- 617 - AM Novice
- 628 - AM Novice Solid

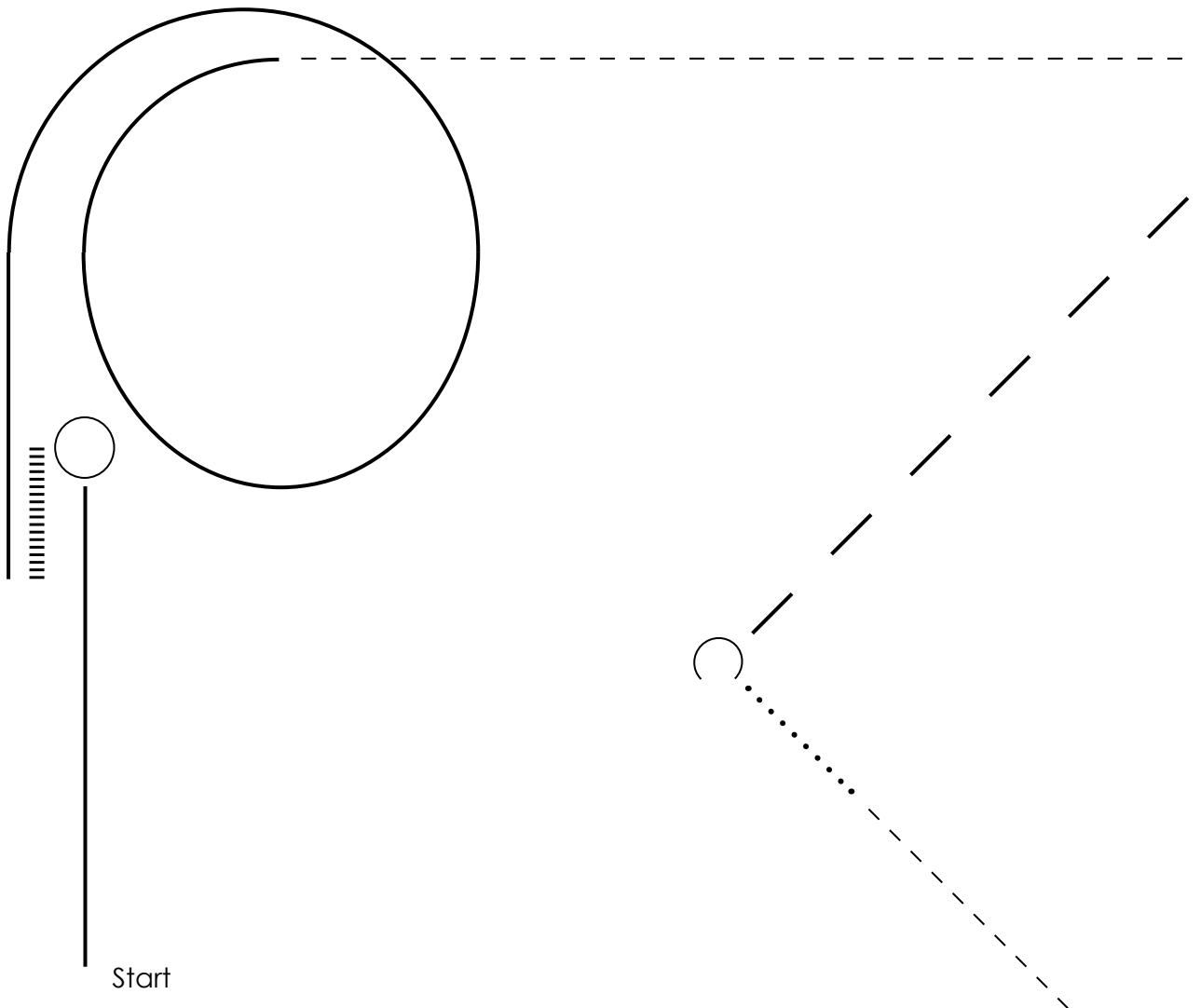

Walk    . . . . .

Jog    - - - -

Ext. Jog    — — —

Lope    —————

Back    |||||

# Western Horsemanship

## Instructions

1. Jog, stop
2. Execute  $\frac{3}{4}$  turn left on the haunches
3. Lope, right lead
4. Walk
5. Lope, left lead
6. Jog
7. Extended jog, stop
8. Back one horse length
9. Jog to exit

## Classes

### PRELIM

- 552 - YA SR
- 614 - AM JR
- 615 - AM SR

### FINAL

- 551 - YA JR
- 616 - AM Elite
- 679 - AM Jr Solid
- 680 - AM Sr/El Solid

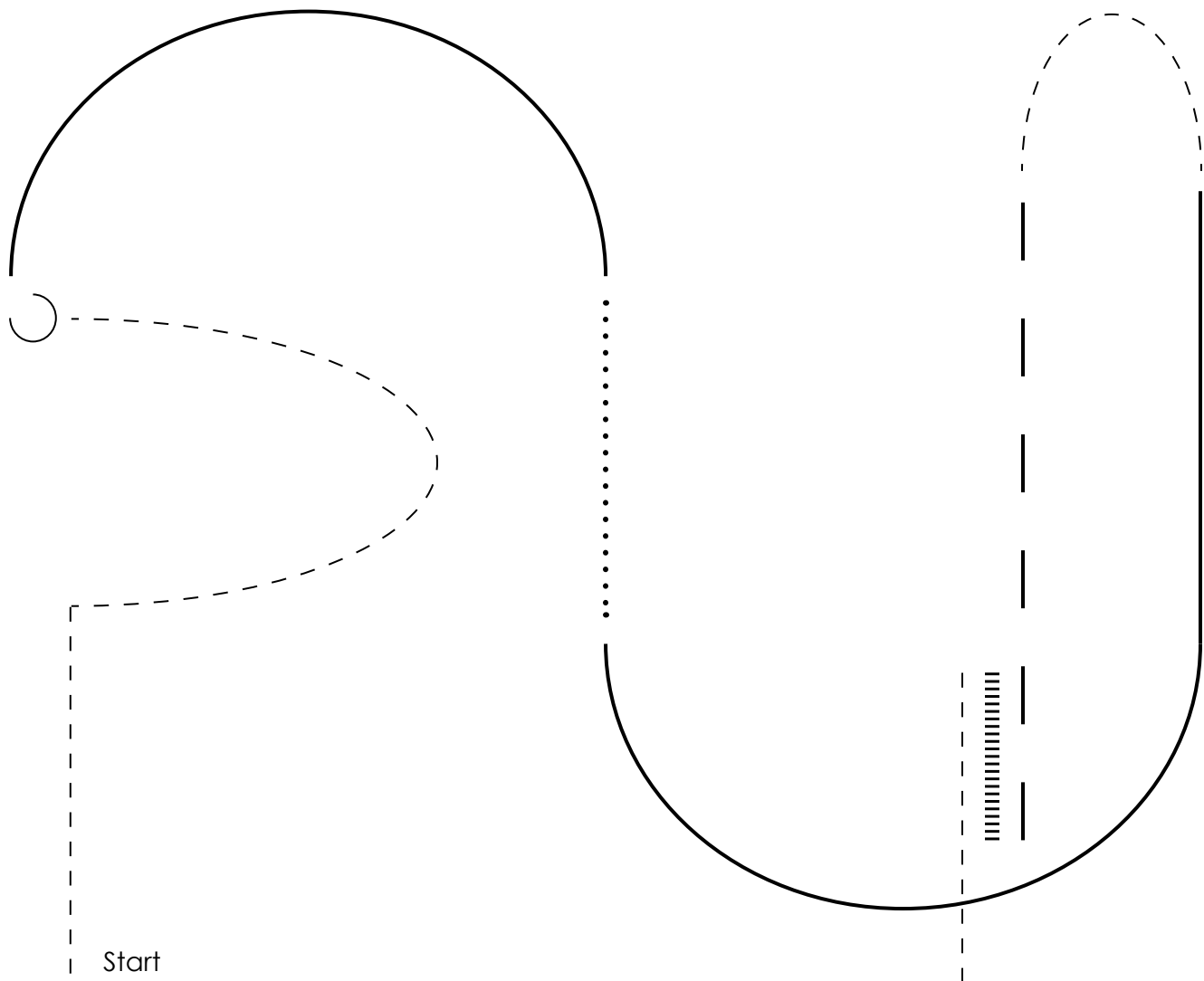

Walk .....

Jog - - - -

Ext. Jog — — — —

Lope —————

Back |||||





# Western Horsemanship

## Instructions

1. Jog
2. Extended jog, stop
3. Execute 1 turn right on the haunches
4. Extended jog
5. Jog, stop
6. Back one horse length
7. Walk to exit

## Classes

### PRELIM

- 524 - YA Walk/Trot 11-18
- 525 - YA Walk/Trot 11-18 Solid
- 526 - YA Walk/Trot 10&U
- 625 - AM Jr Walk/Trot
- 626 - AM Sr Walk/Trot
- 627 - AM Elite Walk/Trot
- 681 - AM Jr Walk/Trot Solid
- 682 - AM Sr/El Walk/Trot Solid

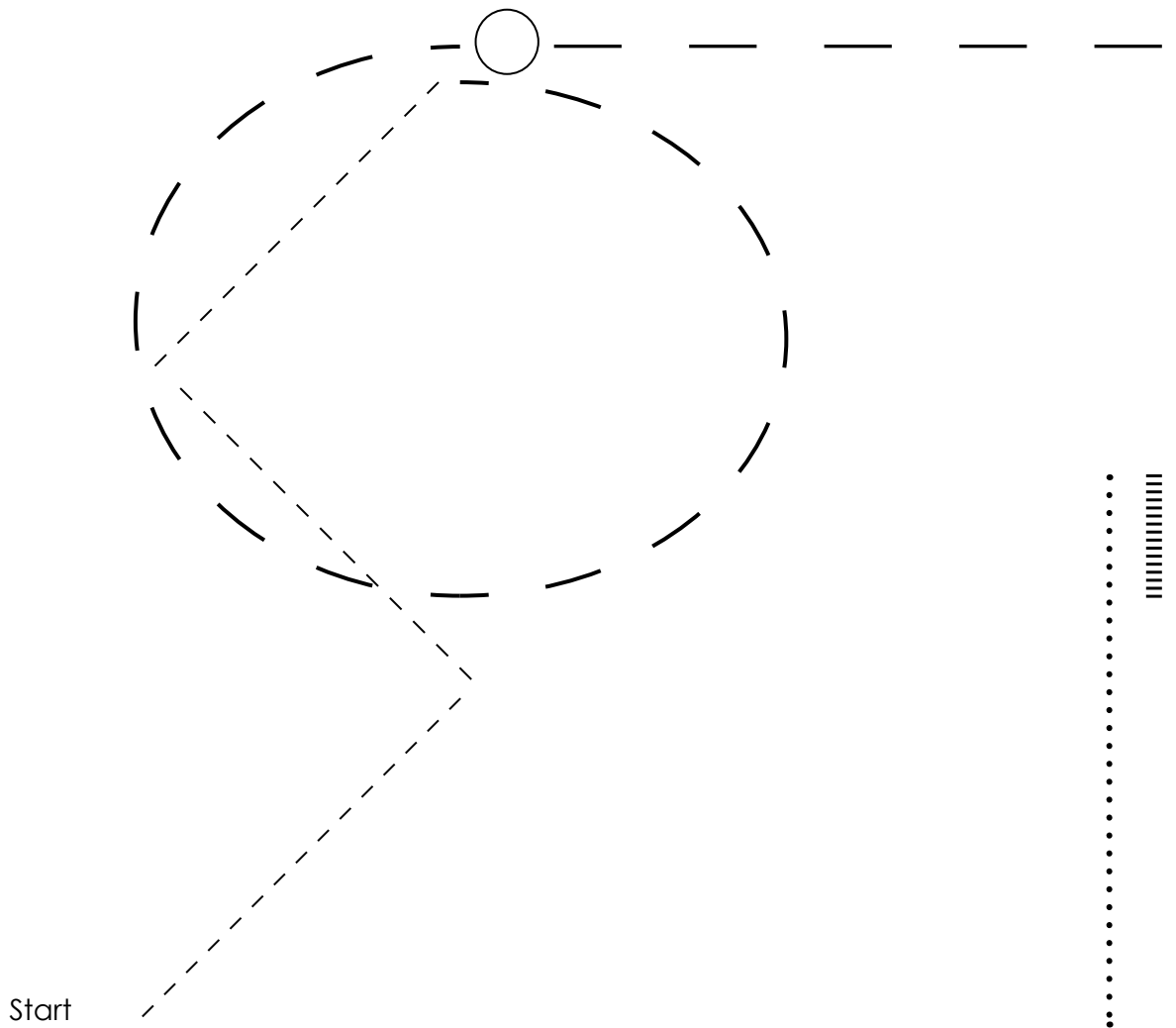

Walk .....

Jog - - - -

Ext. Jog — — — —

Back |||||

# Western Horsemanship

## Classes

### FINALS

- 524 - YA Walk/Trot 11-18
- 525 - YA Walk/Trot 11-18 Solid
- 526 - YA Walk/Trot 10&U
- 527 - YA Walk/Trot 10&U Solid
- 528 - YA Leadline Walk/Trot
- 529 - YA Leadline Walk/Trot Solid
- 625 - AM Jr Walk/Trot
- 626 - AM Sr Walk/Trot
- 627 - AM Elite Walk/Trot
- 681 - AM Jr Walk/Trot Solid
- 682 - AM Sr/El Walk/Trot Solid

## Instructions

1. Walk
2. Jog, stop
3. Execute  $\frac{3}{4}$  turn left on the haunches
4. Extended jog
5. Jog
6. Extended jog
7. Walk, stop
8. Back one horse length
9. Walk to exit.

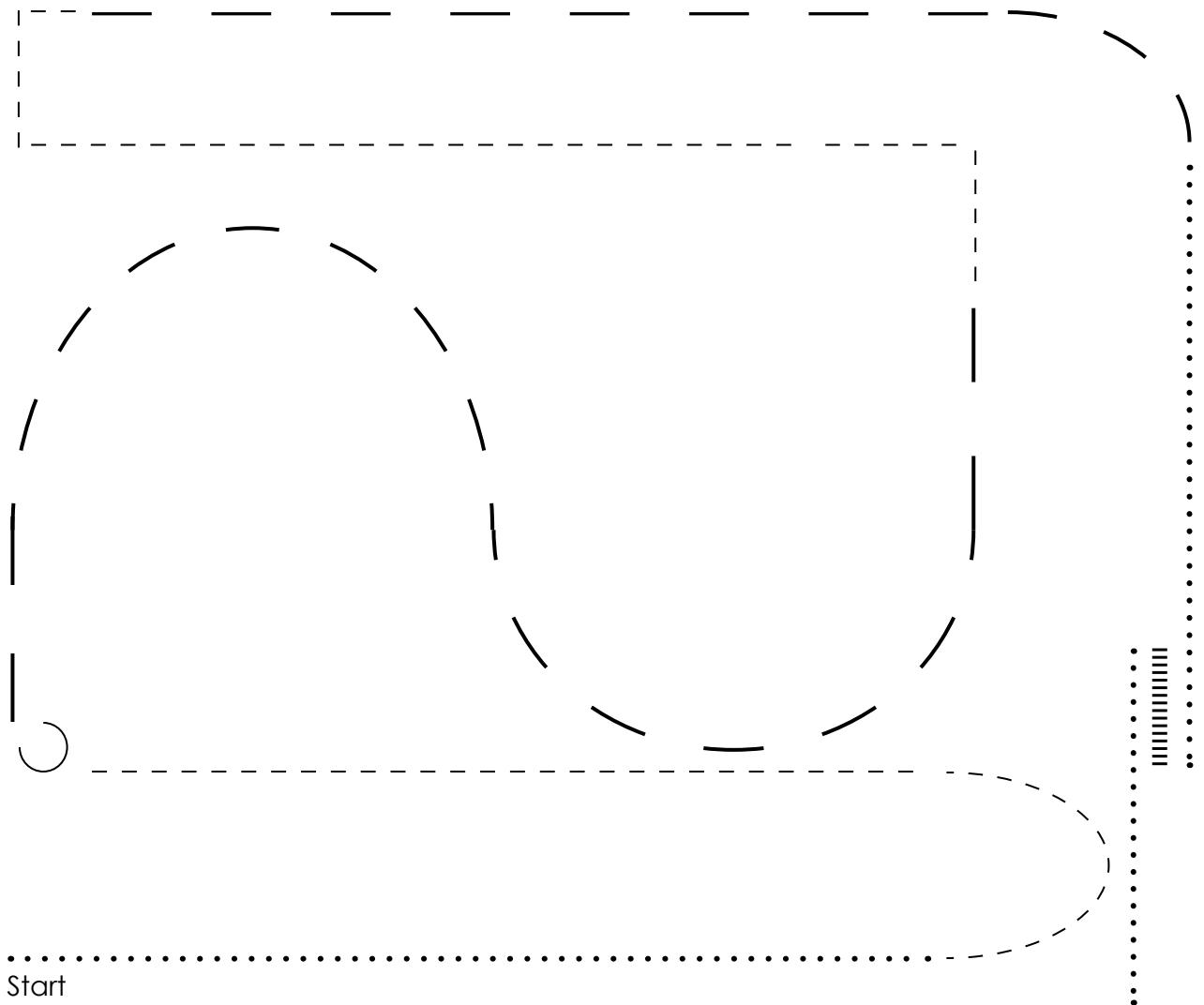

Start

Walk ..... Jog - - - - Ext. Jog — — — — Back |||||

# Bareback Western Horsemanship

## Instructions

1. Walk several strides
2. Lope, left lead
3. Extended jog
4. Lope, right lead
5. Jog, stop
6. Execute  $\frac{3}{4}$  turn left on the haunches
7. Back two horse lengths
8. Execute  $\frac{1}{2}$  turn right on the haunches
9. Walk to exit

## Classes

PRELIM  
545 - YA Solid  
546 - YA Jr  
547 - YA Sr

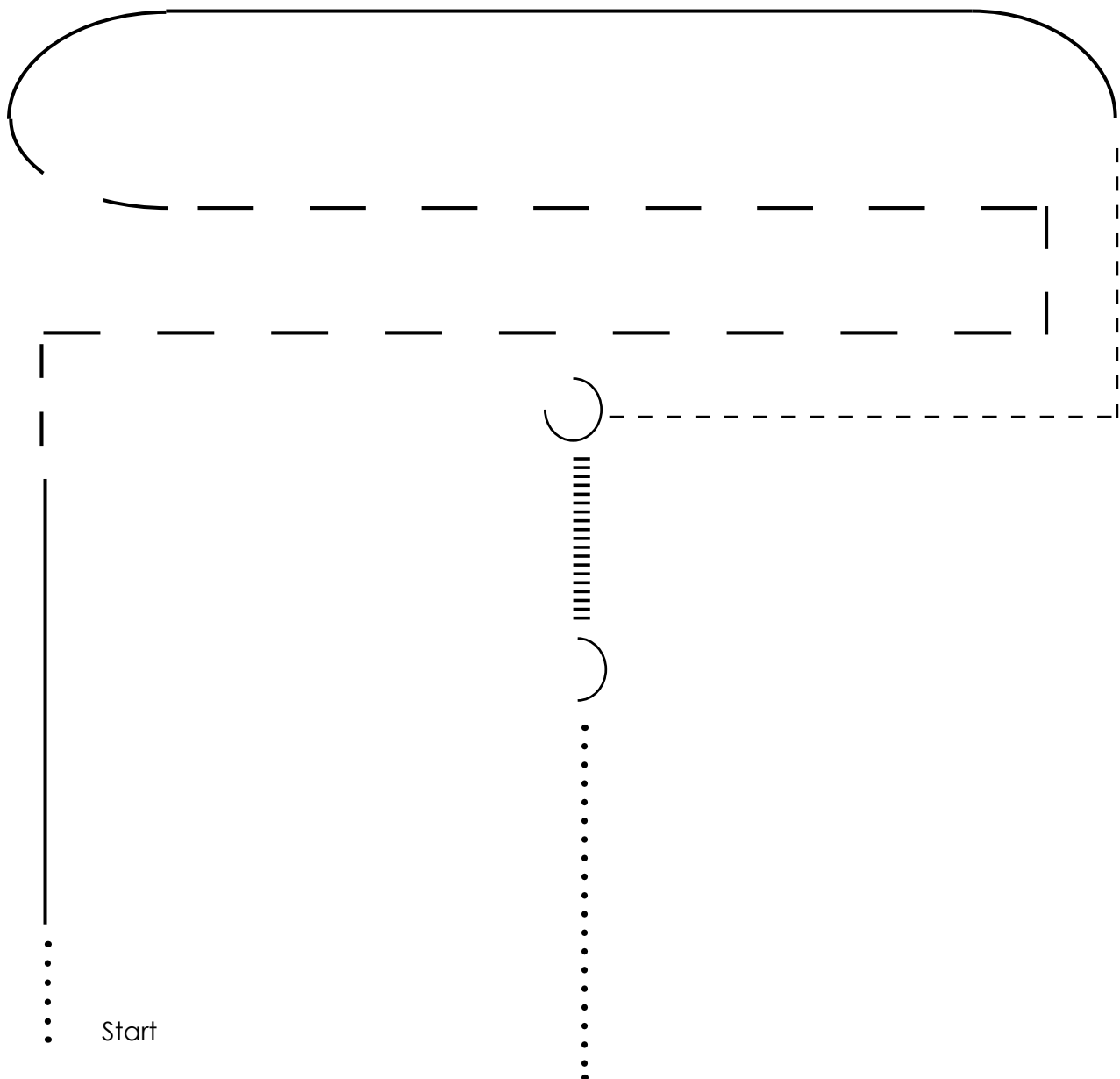

Walk . . . . .

Jog - - - -

Lope ————

Back |||||

# Bareback Western Horsemanship

## Classes

*FINALS*  
 545 - YA Solid  
 546 - YA Jr  
 547 - YA Sr  
 570 - AM  
 571 - AM Solid

## Instructions

1. Walk
2. Jog
3. Lope, right lead
4. Jog
5. Lope, left lead, stop
6. Execute  $\frac{3}{4}$  turn left on the haunches
7. Back one horse length
8. Extended jog to exit

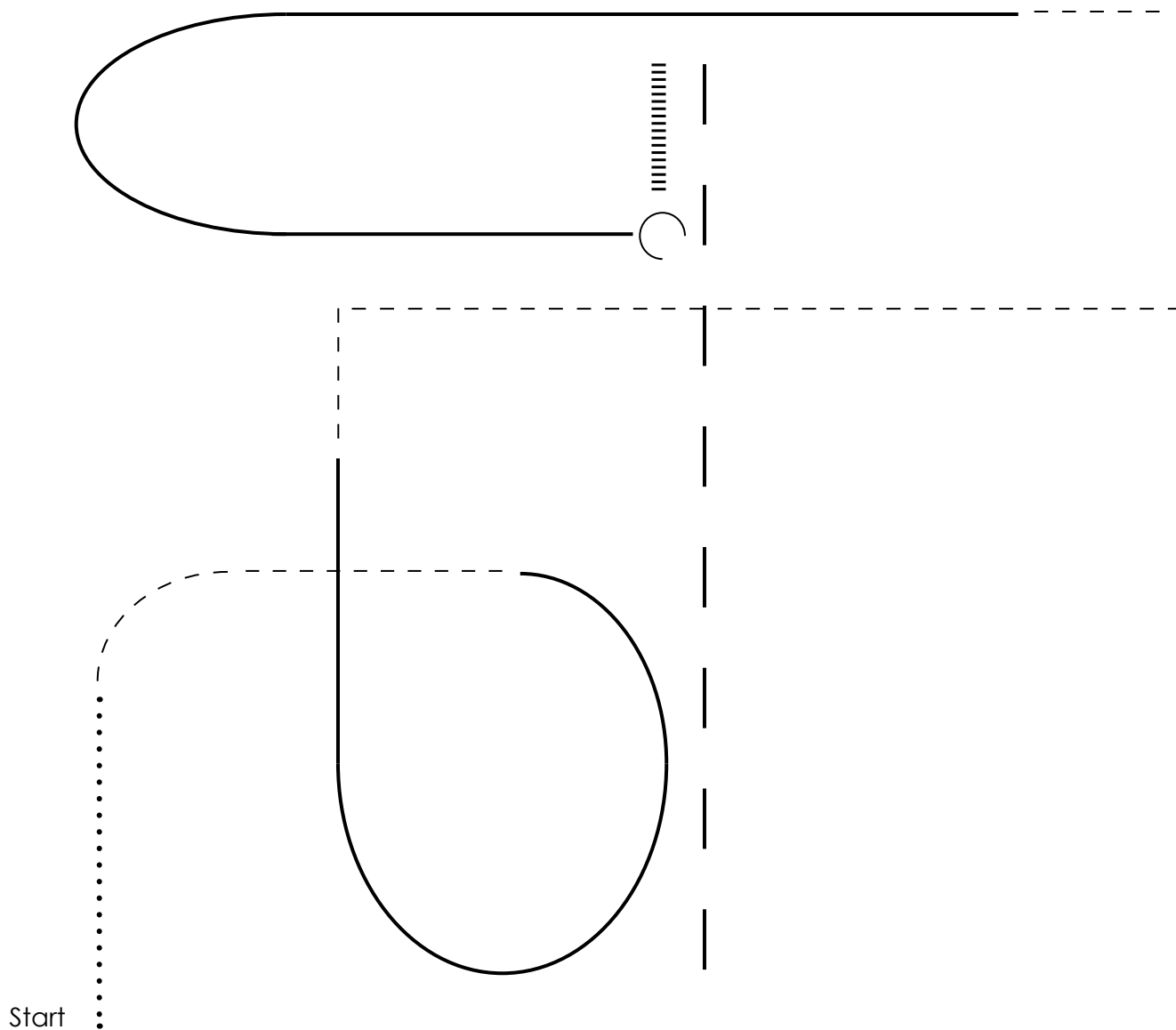

Walk .....

Jog - - - -

Ext. Jog - - - -

Lope ————

Back |||||

# Ranch Horsemanship

## Instructions

1. Back two horse lengths
2. Execute 1½ turn right on the haunches
3. Jog
4. Lope, right lead
5. Extended jog
6. Lope, left lead
7. Walk to exit.

## Classes

- 39 - YA
- 41 - YA Solid
- 43 - AM
- 45 - AM Solid

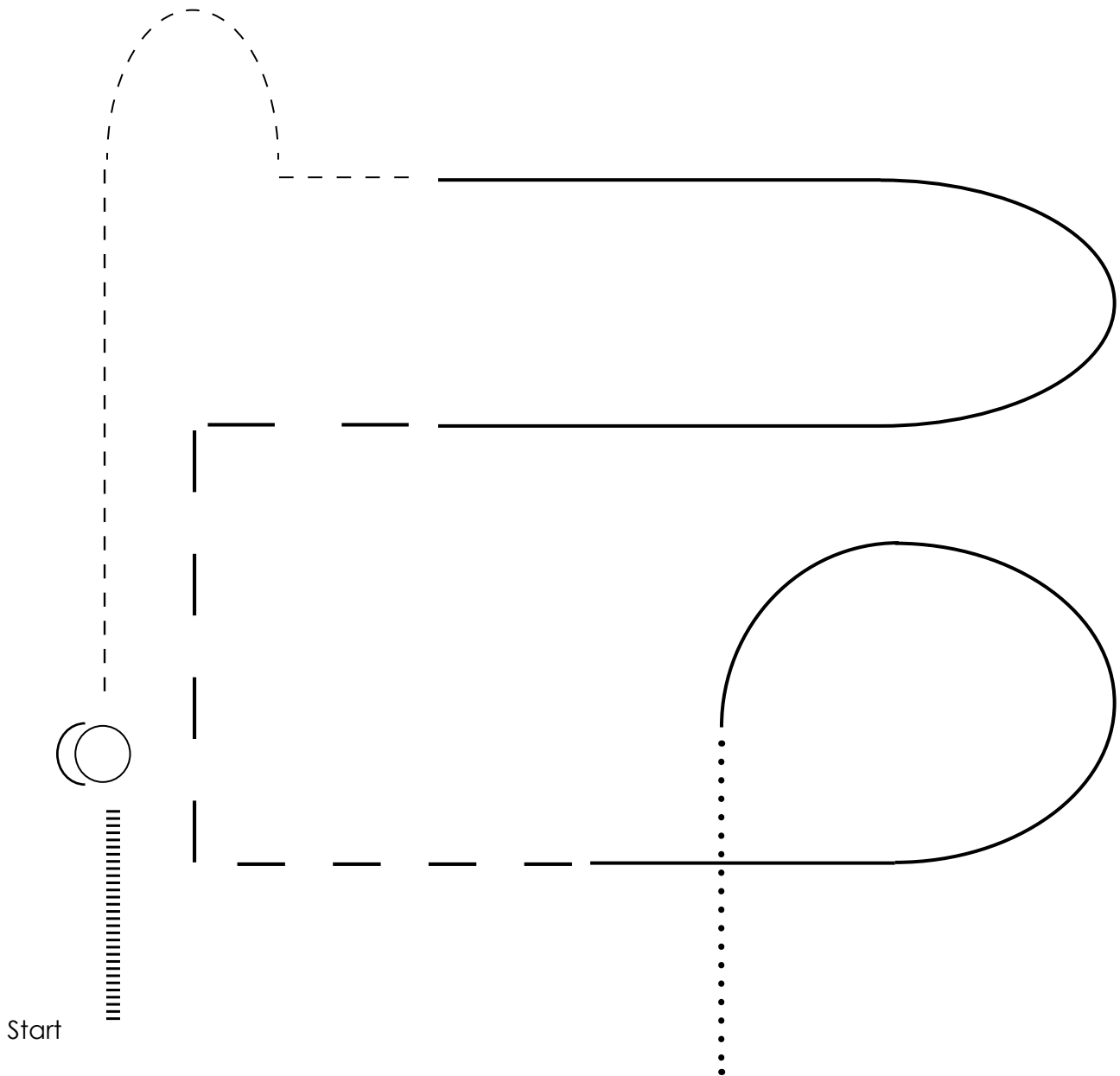

Walk    ······

Jog    - - - -

Ext. Jog    — — —

Lope    —————

Back    |||||

# Ranch Horsemanship

## Classes

- 40 - YA Walk/Trot 11-18
- 42 - YA Walk/Trot 11-18 Solid
- 44 - AM Walk/Trot
- 46 - AM Walk/Trot Solid

## Instructions

1. Back two horse lengths
2. Execute 1½ turn right on the haunches
3. Jog
4. Walk
5. Extended jog
6. Jog
7. Walk to exit.

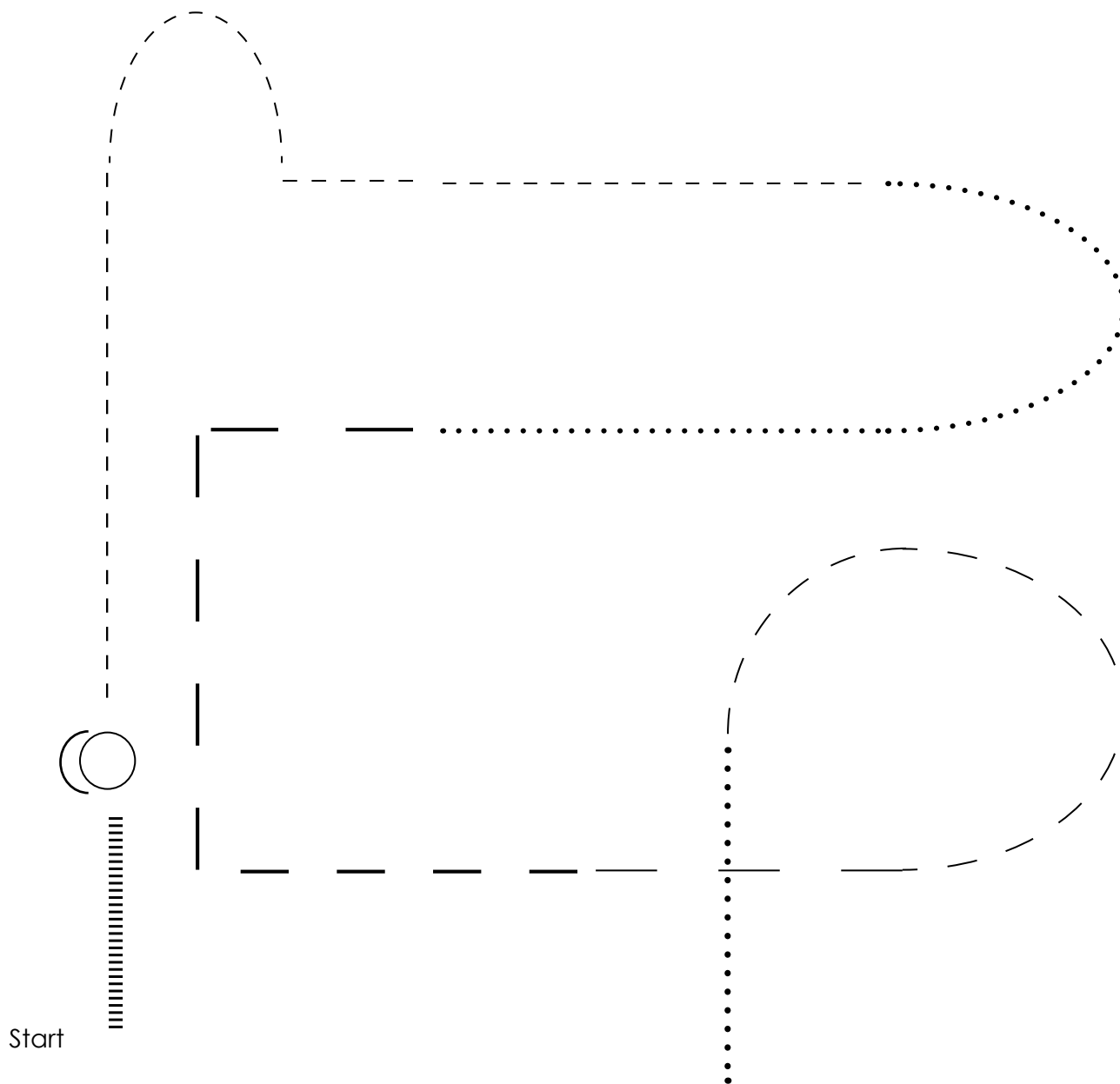

Walk    . . . . .

Jog    - - - - -

Ext. Jog    — — — — —

Back

|||||

# Ranch Riding

## Classes

- 86 - OP JR
- 87 - OP SR
- 88 - OP JR Solid
- 89 - OP SR Solid

## Instructions

### Pattern #15

1. Extended trot
2. Stop, roll back right
3. Lope right lead
4. Extended lope (right lead)
5. Trot
6. Walk
7. Walk over logs
8. Walk
9. Trot
10. Stop, 360 left
11. Lope left lead
12. Stop and back

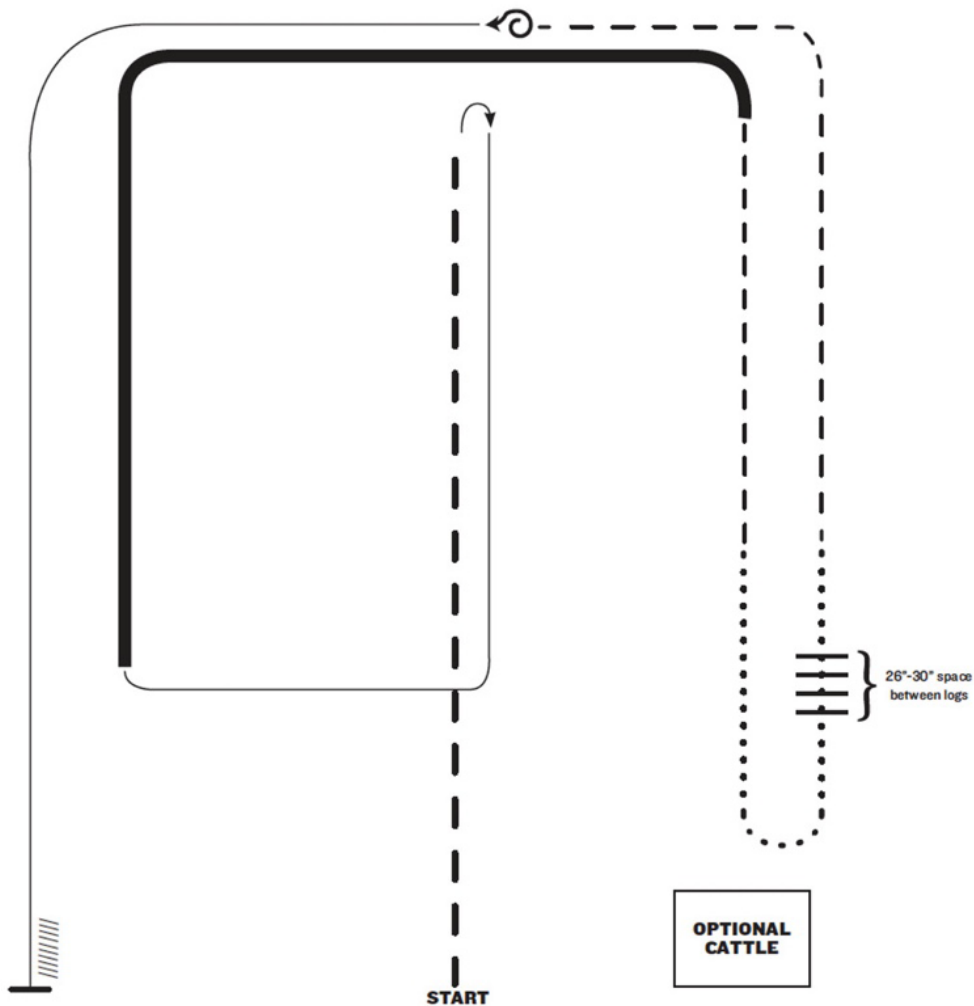



# Ranch Riding

## Instructions

### Pattern #12

1. Walk
2. Trot
3. Trot logs
4. Side pass right
5. 1 ½ turns right
6. Extended lope (right lead)
7. Lope right lead
8. Extended trot
9. Lope left lead
10. Walk
11. Trot
12. Stop and back

## Classes

- 90 - AM
- 92 - AM Solid
- 94 - YA
- 96 - YA Solid

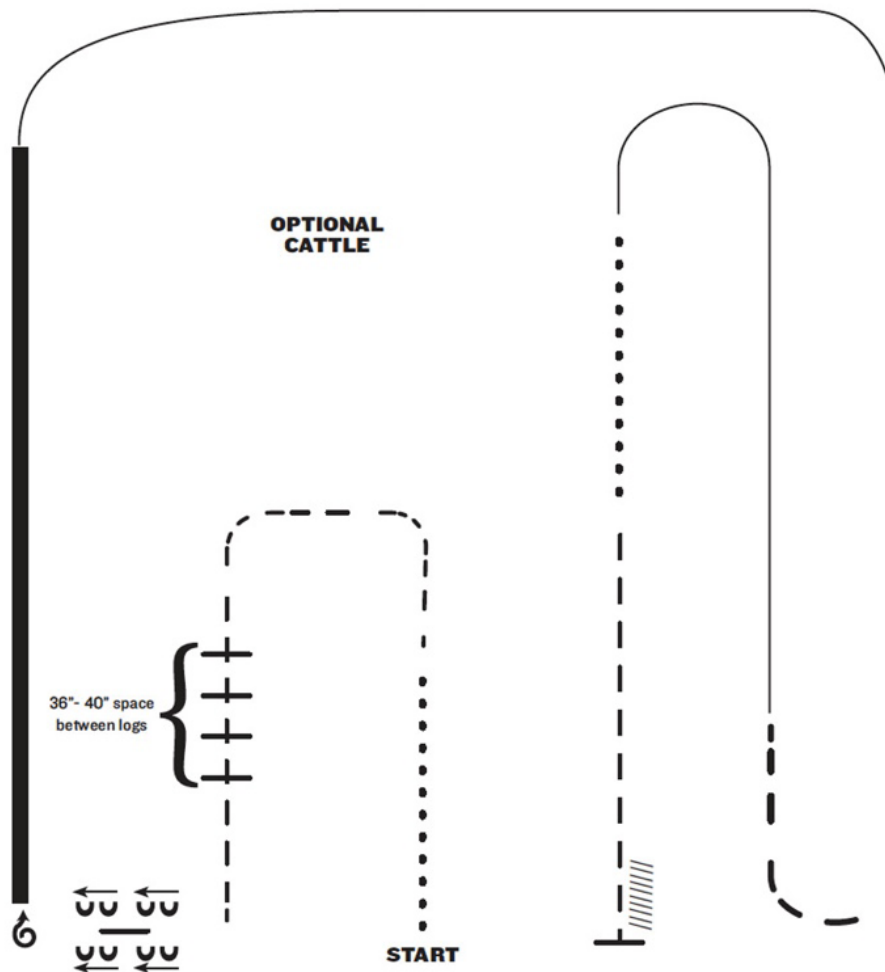

# Ranch Riding

## Classes

- 91 - AM Walk/Trot
- 93 - AM Walk/Trot Solid
- 95 - YA Walk/Trot 11-18
- 97 - YA Walk/Trot 11-18 Solid

## Instructions

1. Walk
2. Trot over logs
3. Stop, sidepass right
4. Execute 1/2 turn right
5. Extended trot
6. Trot
7. Walk
8. Trot, extended trot
9. Stop, execute 1 turn left
10. Back one horse length

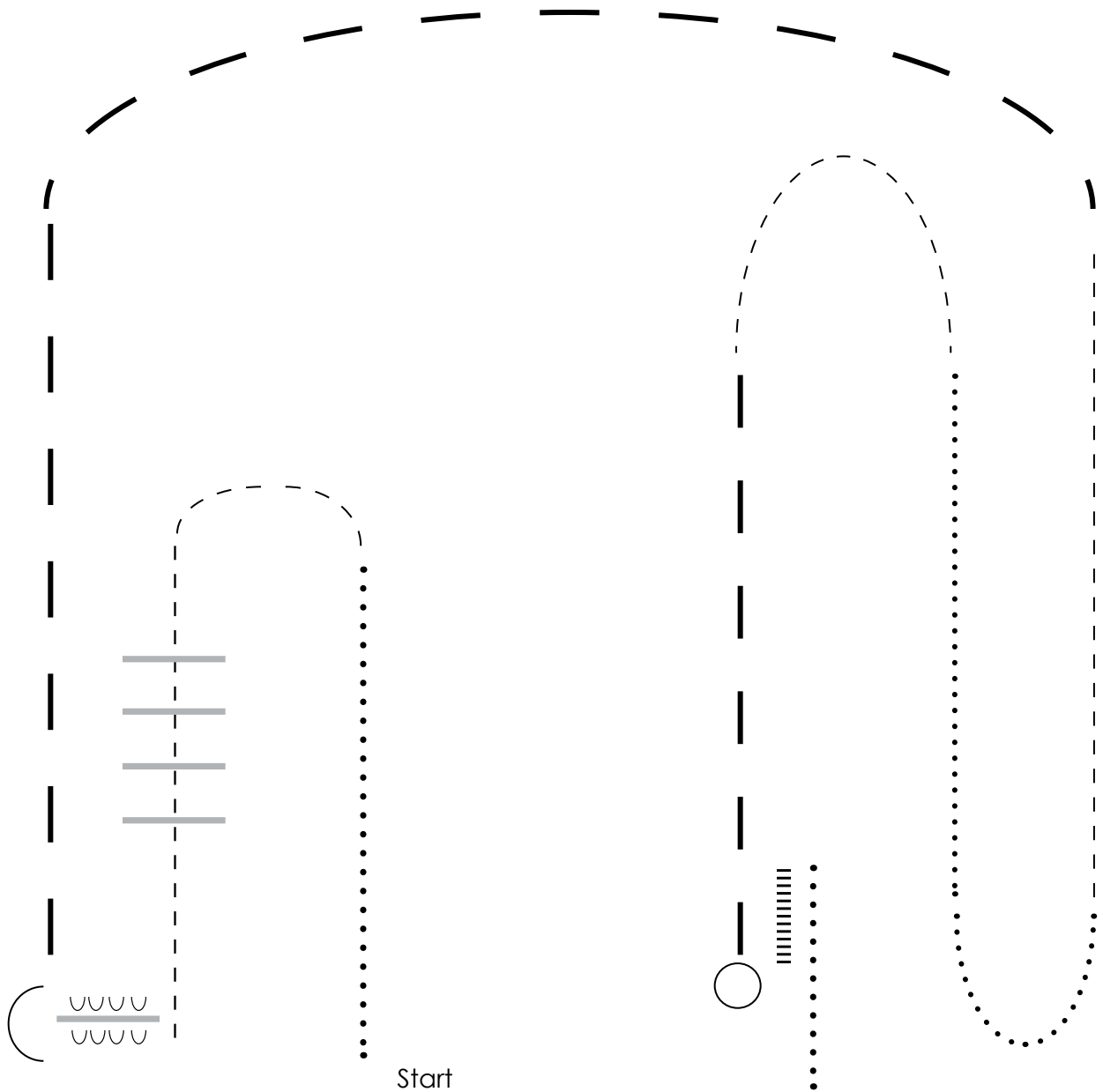

# Ranch Reining

## Instructions

### Pattern #5

1. Run up center of arena past the end marker and do a sliding stop.
2. Complete 3 1/2 spins to the left.
3. Run down to opposite end of arena, past the end marker and do a sliding stop.
4. Complete 3 1/2 spins to the right.
5. Run past the center marker and do a sliding stop. Back at least 10 feet. Complete 1/4 turn to the left; hesitate.
6. Beginning on right lead, complete two circles to the right - the first one small and slow, the second one large and fast. Change leads at center of arena.
7. Complete two circles to the left - the first one small and slow, the second one large and fast. Change leads at center of arena.
8. Begin a large circle to the right but do not close this circle. Run down the right side of the arena, past the center marker and do a sliding stop at least 20 feet from the fence. Hesitate to show completion of pattern.

## Classes

- 98 - OP
- 99 - OP Solid
- 100 - AM
- 101 - AM Solid
- 102 - YA
- 103 - YA Solid

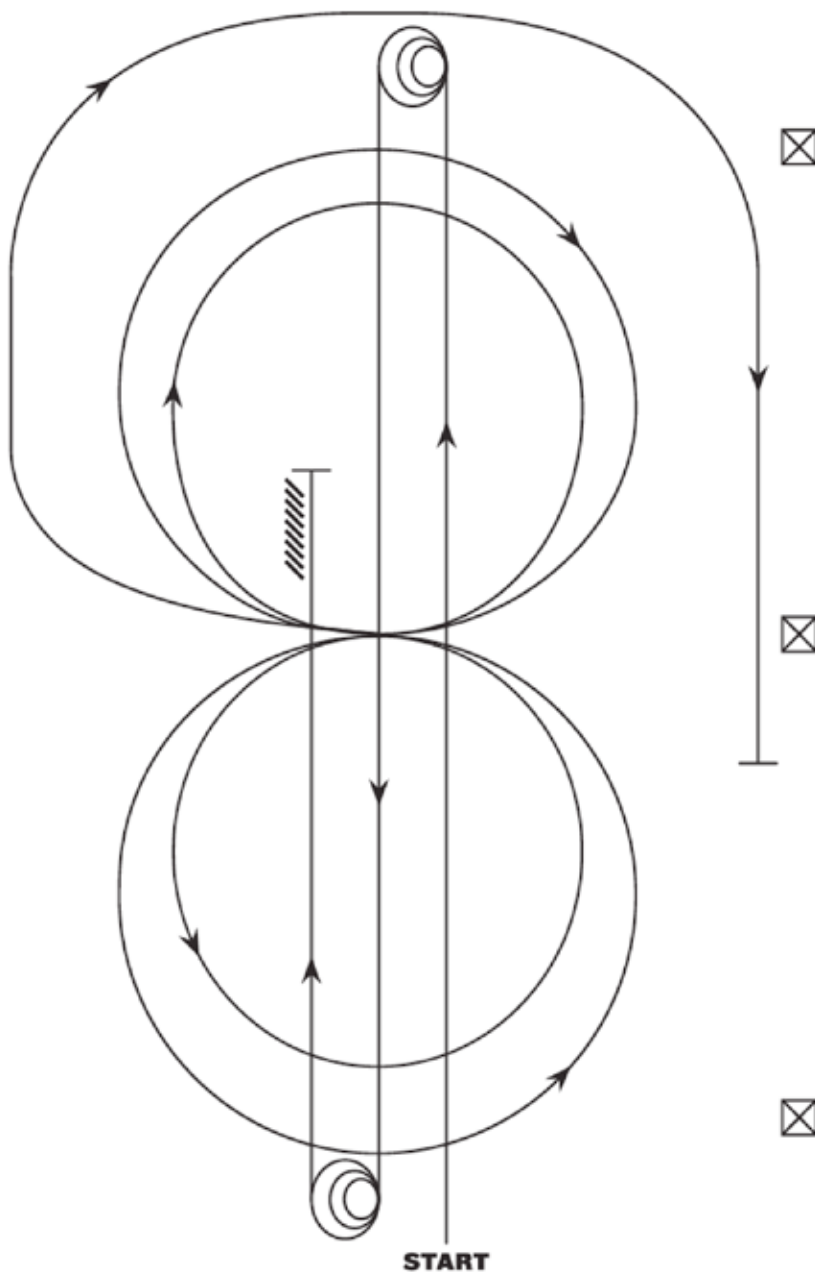

# Western Riding

## Instructions

## Classes

### WESTERN RIDING PATTERN #2

1. Walk, transition to jog, jog over log
2. Transition to left lead lope
3. First crossing change
4. Second crossing change
5. Third crossing change
6. Circle and first line change
7. Second line change
8. Third line change
9. Fourth line change
10. Lope over log
11. Lope, stop & back

- 340 - YA Jr
- 341 - YA Sr
- 342 - YA Solid
- 463 - AM
- 464 - AM Solid

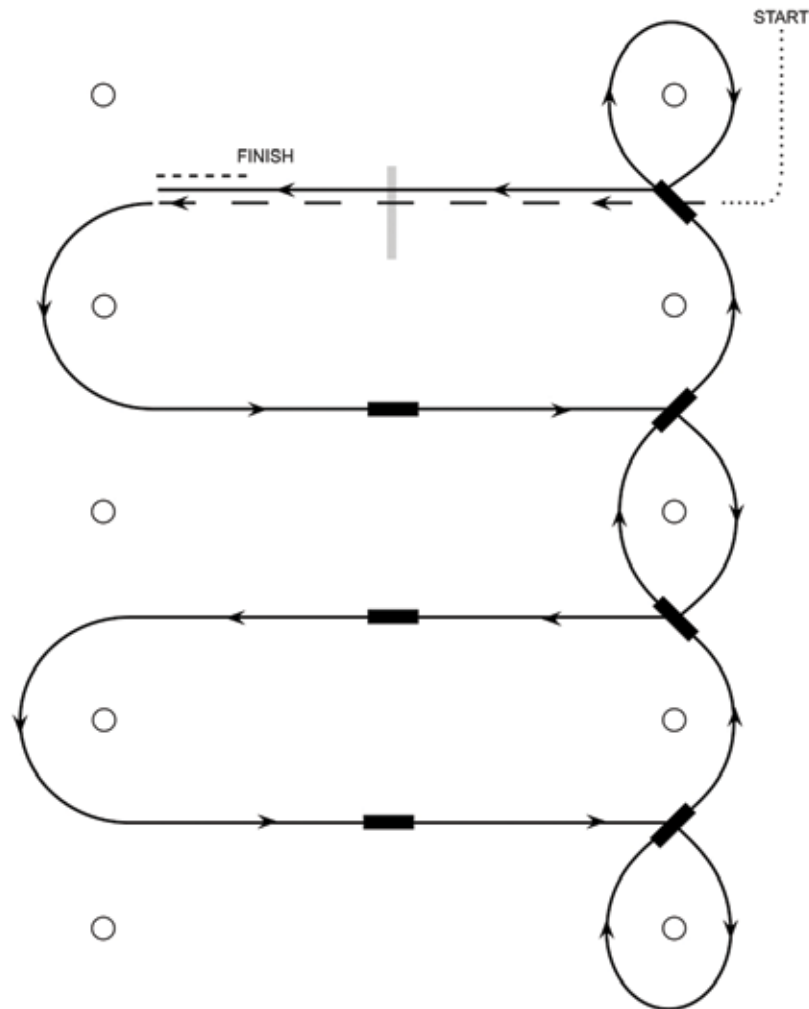

# Western Riding

## Classes

461 - Open Solid  
462 - Open

## Instructions

### WESTERN RIDING PATTERN #3

1. Walk, transition to jog, jog over log
2. Transition to left lead lope
3. First crossing change
4. Lope over log.
5. Second crossing change
6. First line change
7. Second line change
8. Third line change
9. Fourth line change
10. Third crossing change
11. Fourth crossing change
12. Lope up the center, stop & back

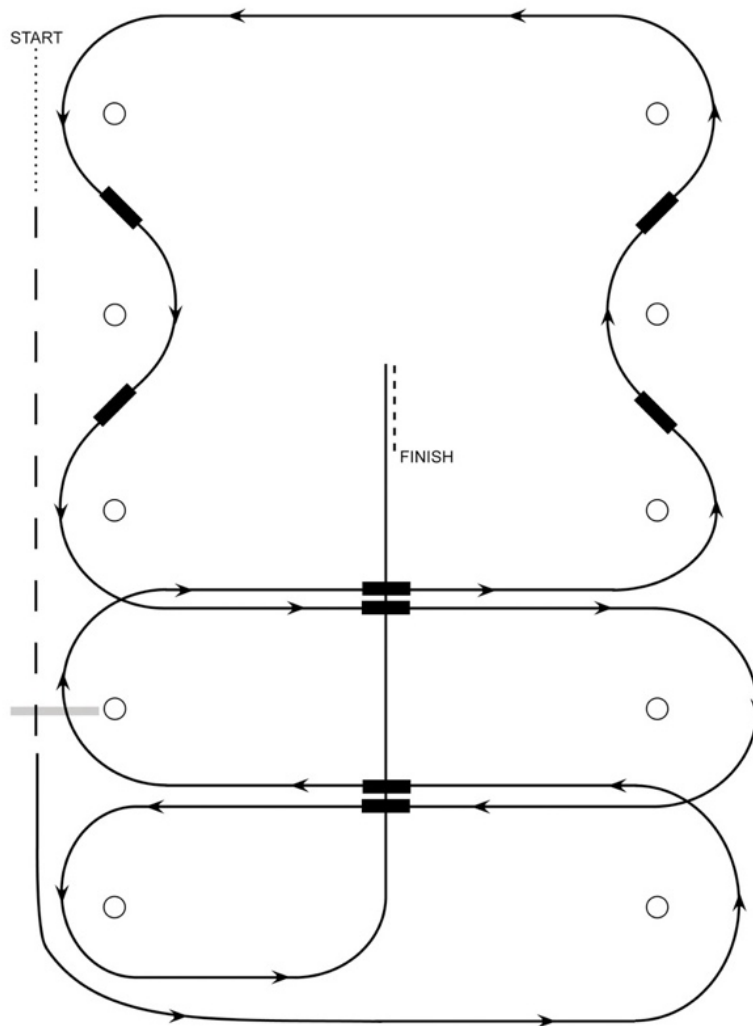

# Western Riding

## Classes

460 - Open, Green

## Instructions

### GREEN WESTERN RIDING PATTERN #3

1. Walk, transition to log, jog over log.
2. Transition to right lead and lope around end.
3. First line change.
4. Second line change, lope around end of arena.
5. First crossing change.
6. Second crossing change.
7. Third crossing change.
8. Lope over log.
9. Lope, stop and back.

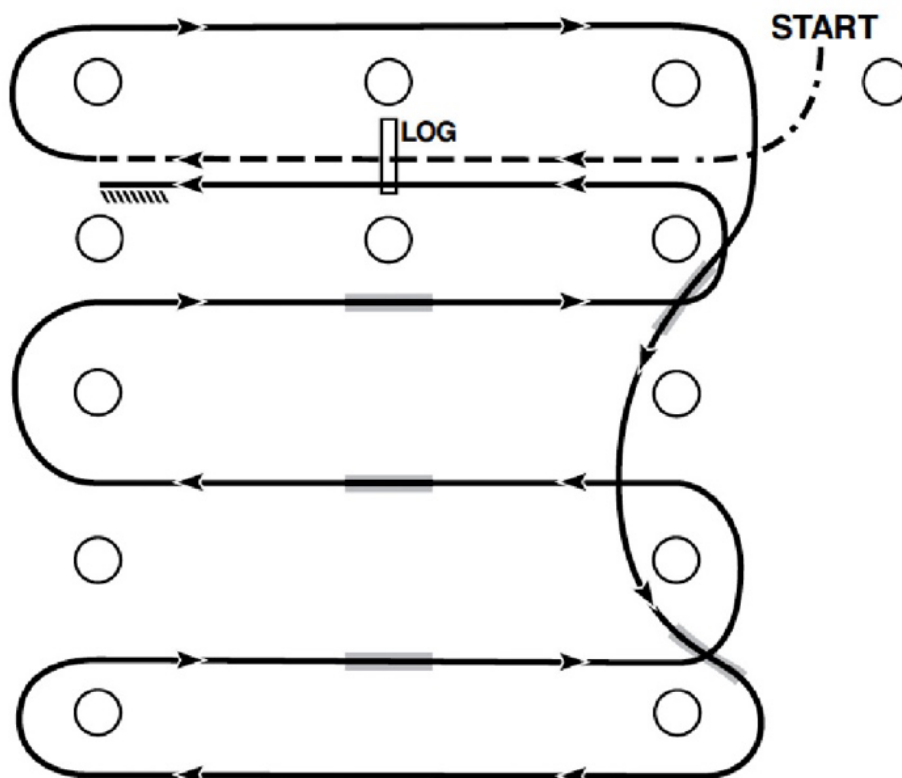

# Hunter Hack

## Classes

1. Canter over fences.
2. After 2nd fence, hand gallop to marker.
3. Halt and back at marker.

## Instructions

- 234 - AM Novice, 2'3"-2'9"
- 235 - YA Novice, 2'3"-2'9"
- 236 - Open, 2'3"-2'9"
- 237 - Open Solid, 2'3"-2'9"
- 238 - AM, 2'3"-2'9"
- 239 - AM Solid, 2'3"-2'9"
- 240 - YA, 2'3"-2'9"
- 241- YA Solid, 2'3"-2'9"

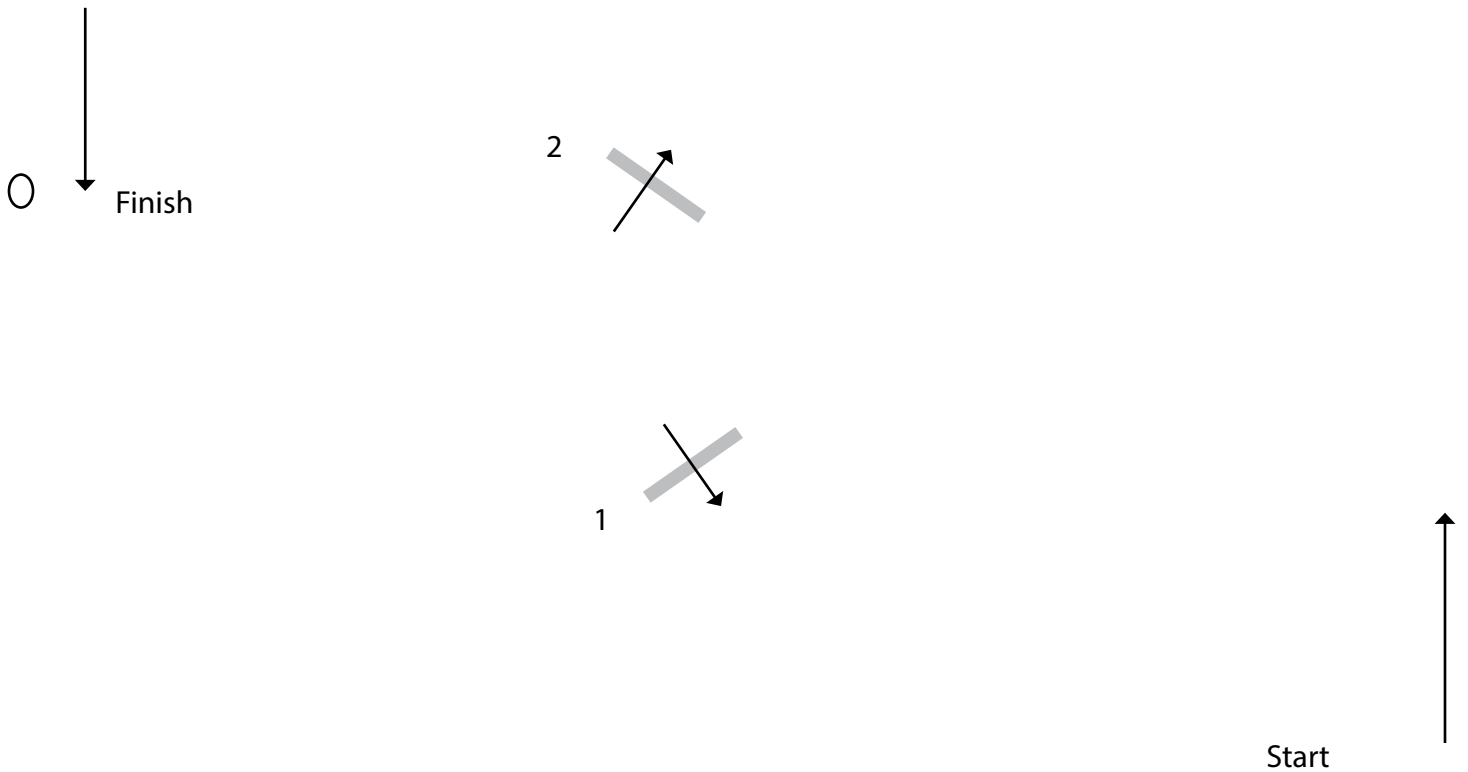

Course by Hailey Rogge

Path ———

Fence ———

# Working Hunter Over Fences

## Instructions

Jump fences 1-8

## Classes

- 227 - Open Green, 2'3"-2'9"
- 228 - Open Solid, 2'3"-2'9"
- 229 - AM, 2'3"-2'9"
- 230 - AM Solid, 2'3"-2'9"
- 231 - Open 2'3"-2'9"

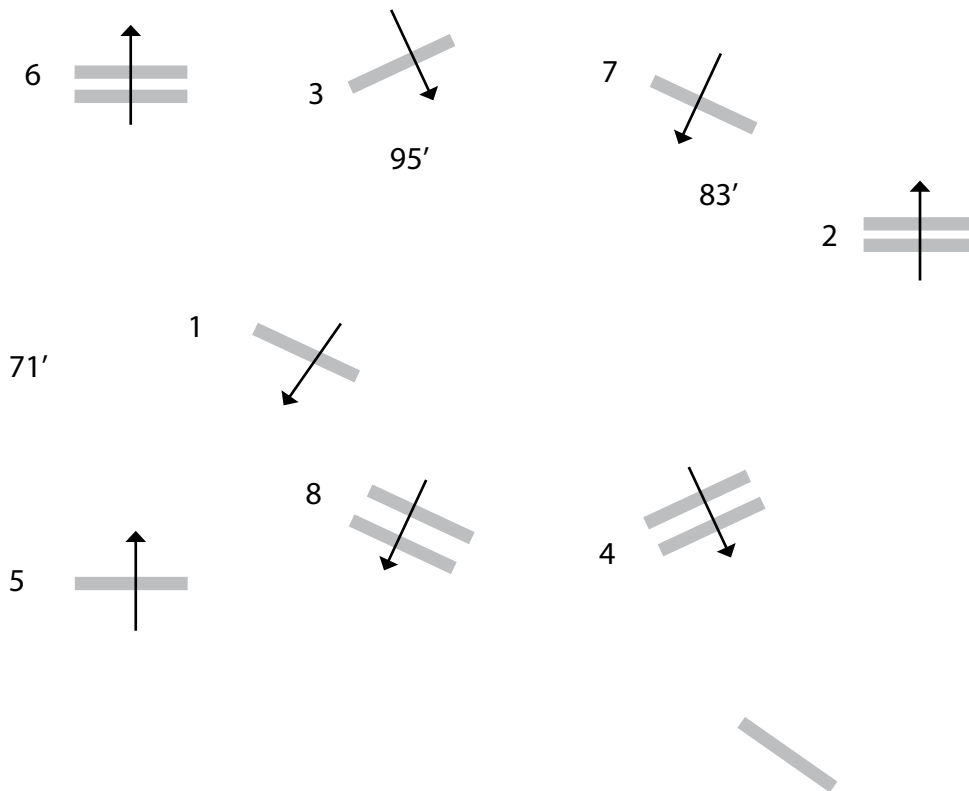

Course by Hailey Rogge

Path ———

Fence ———



# Equitation Over Fences

## Classes

232 - AM, 2'3"-2'9"

## Instructions

Jump fences 1-8

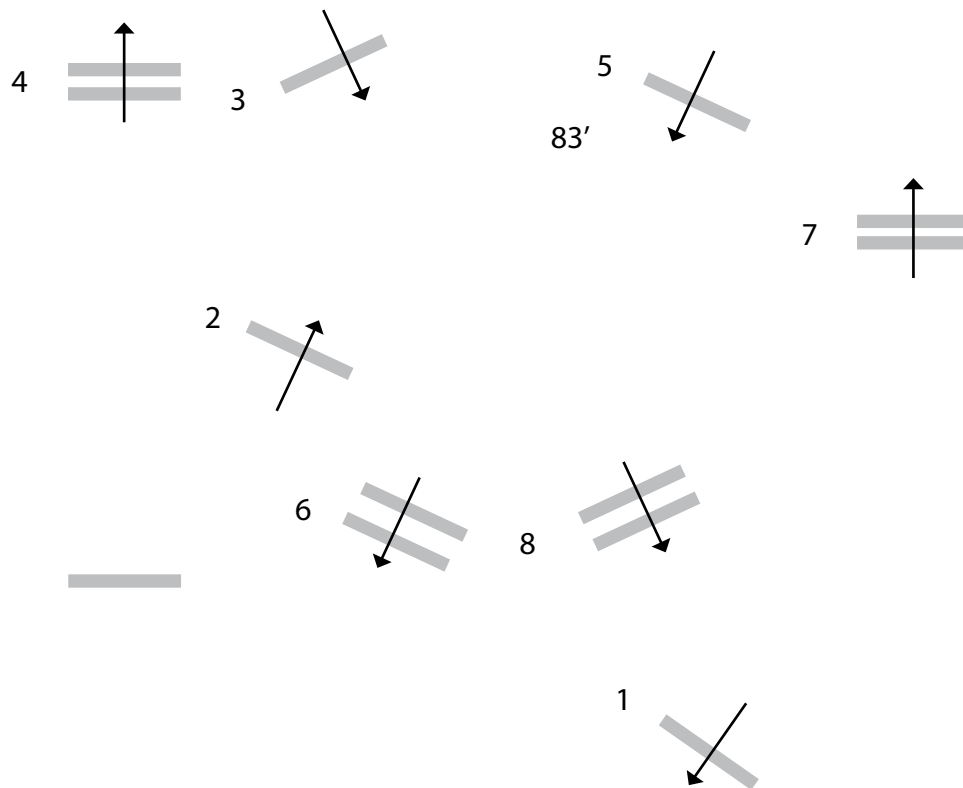

Course by Hailey Rogge

Path ———

Fence ———

# Jumping

## Instructions

Jump fences 1-9

JUMP OFF 1, 2, 6, 7, 8, 9

## Classes

233 - Open 2'3"-2'9"

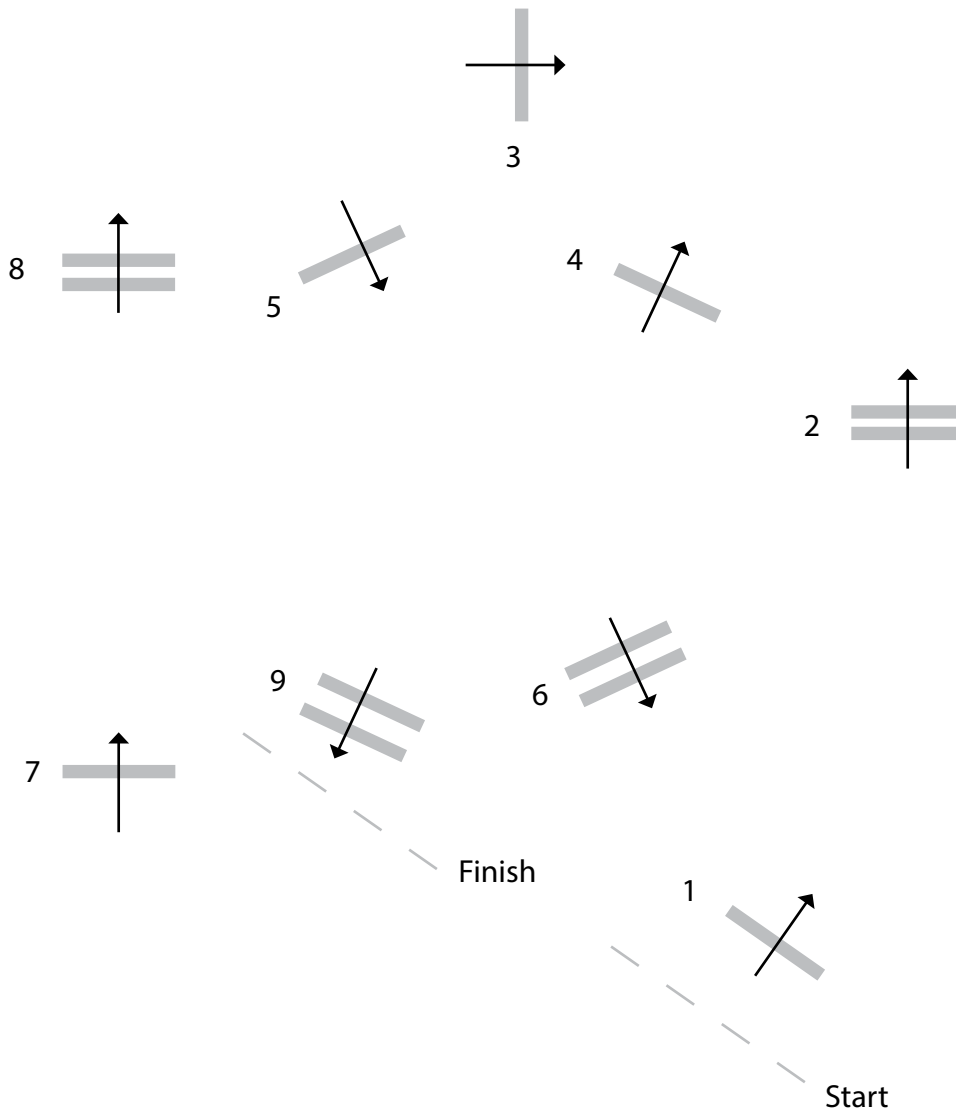

Course by Hailey Rogge

Path ———

Fence ———

# Jumping In-hand

## Classes

- 637 - Miniature
- 638 - B Miniature
- 639 - Solid Miniature/B Miniature
- 640 - Pony
- 641 - AM Miniature/B Miniature/Pony
- 642 - YA Miniature/B Miniature/Pony

## Instructions

- Jump fences 1-6
- Jump off 1-6

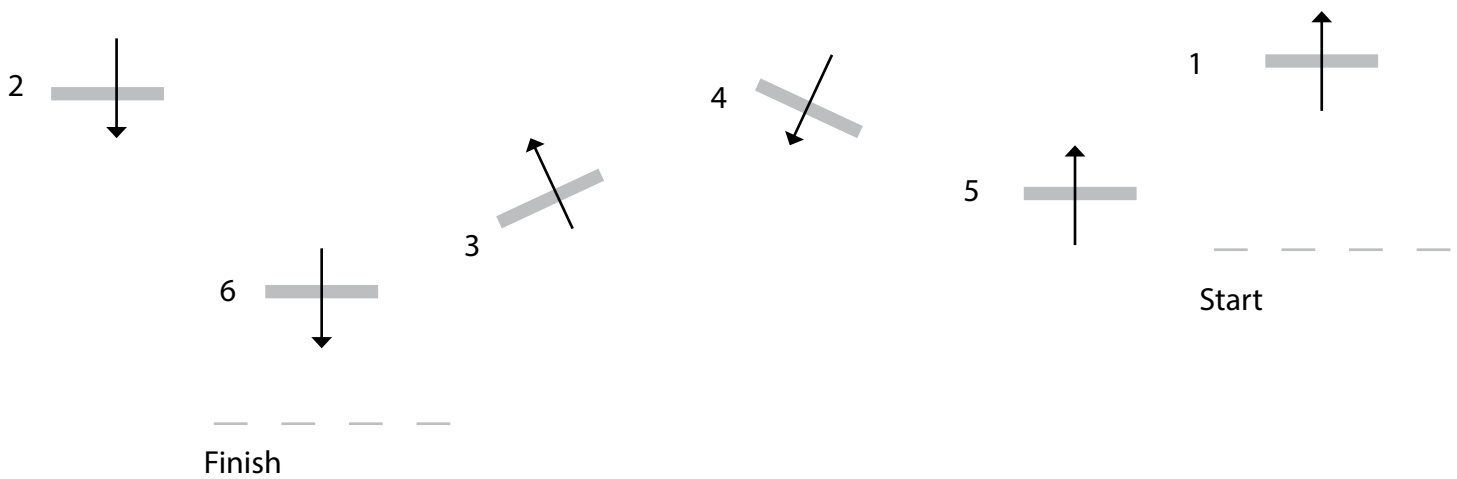

# Hunter Over Fences In-hand

## Instructions

Jump fences 1-6

## Classes

- 631 - Miniature
- 632 - AM Miniature/B Miniature/Pony
- 633 - YA Miniature/B Miniature/Pony
- 634 - B Miniature
- 635 - Solid Miniature/B Miniature
- 636 - Pony

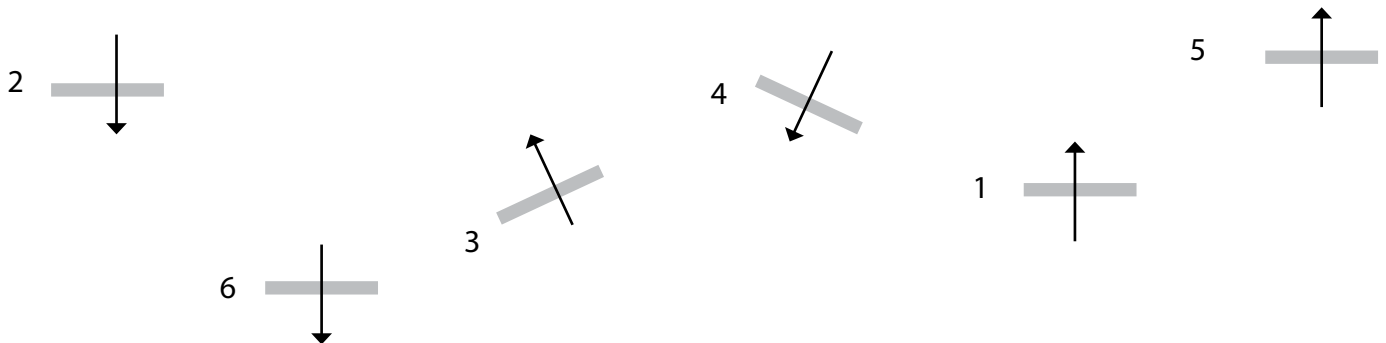

Tim Kimura • Copyright 2024 • All Rights Reserved

Path 

Fence 

# Trail In-Hand

## Classes

- 534 - OP Miniature
- 535 - OP B Miniature
- 536 - OP Solid Miniature/B Miniature
- 537 - AM Mini/B Mini
- 538 - YA Mini/B Mini
- 539 - OP Pony
- 540 - AM Pony
- 541 - YA Pony

## Instructions

1. Walk into box, execute 1 turn, either direction, walk out of box
2. Jog through serpentine and over poles
3. Jog over poles
4. Stop or break to walk, walk over poles
5. Jog over poles
6. Stop or break to walk, walk over poles and up to gate, work gate, left hand
7. Sidepass right, back around corner and between poles
8. Walk out of chute and over poles to exit

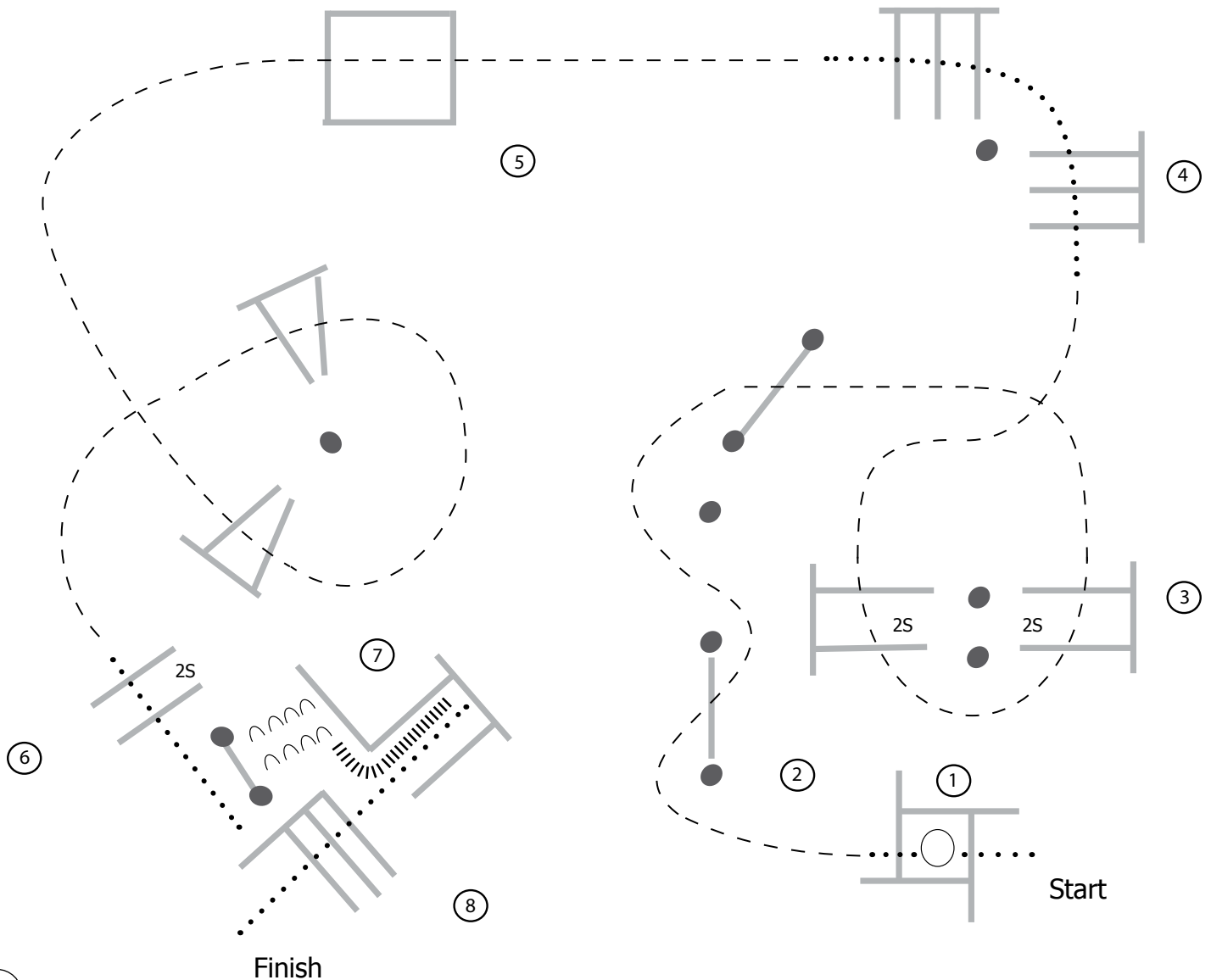

Tim Kimura • Copyright 2024 • All Rights Reserved

Walk .....

Jog - - -

Back|||||||

# Trail In-Hand

## Instructions

1. Start at gate, work gate, left hand
2. Walk between poles and over bridge
3. Jog through serpentine
4. Stop or break to walk, walk into box, execute 1 turn right, walk out of box
5. Jog over poles
6. Jog into chute, back around corner and between poles
7. Walk out of chute, walk over poles

## Classes

- 588 - AM Yearling
- 589 - AM Yearling Solid
- 590 - OP Yearling
- 591 - OP Yearling Solid
- 592 - AM Two-Year Old
- 593 - AM Two-Year Old Solid
- 594 - OP Two-Year Old
- 595 - OP Two-Year Old Solid

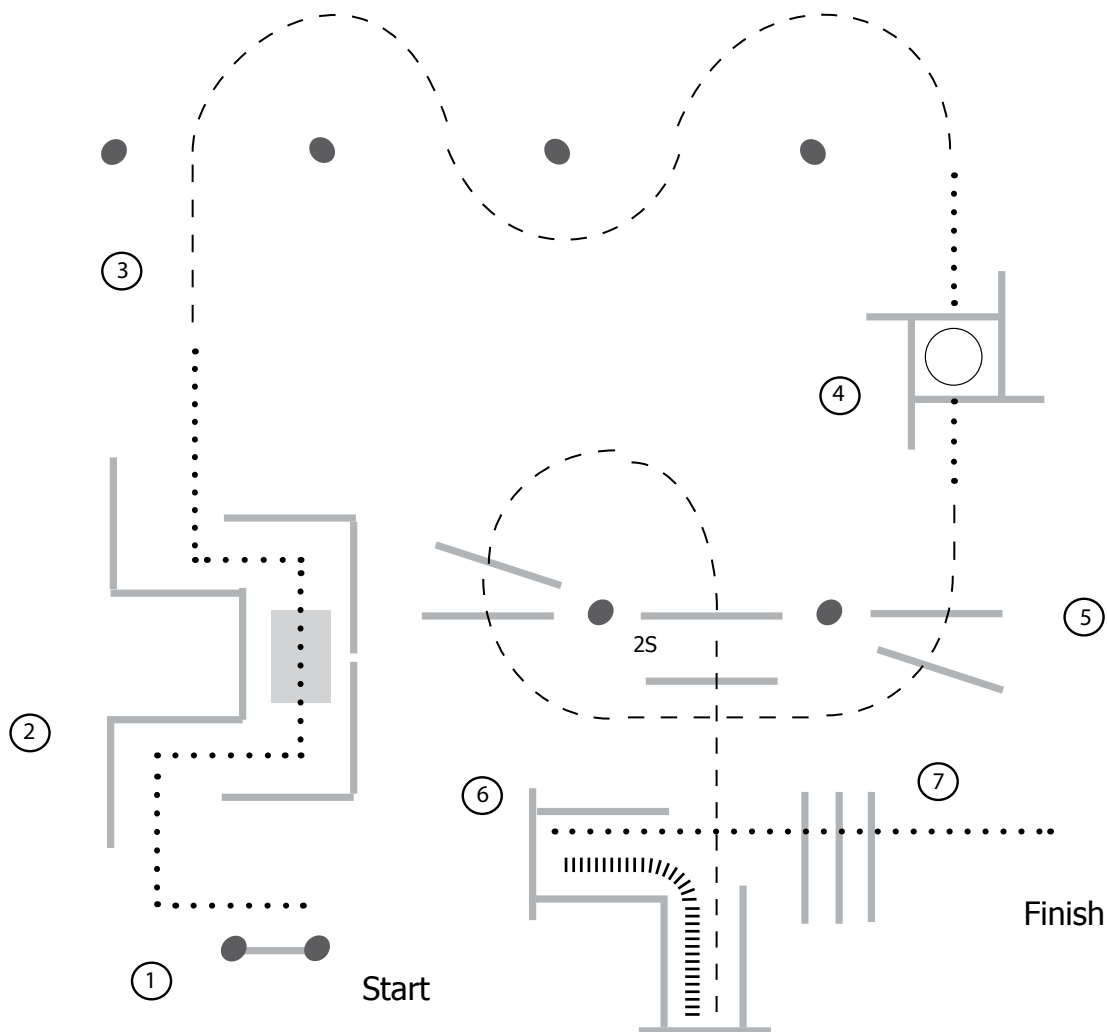

Tim Kimura • Copyright 2024 • All Rights Reserved

Walk .....

Jog - - -

Back ||||||||||

# Trail

## Classes

- 350 - YA WT 11-18, Western
- 351 - YA WT 11-18, Western Solid
- 352 - YA WT 10&U, Western
- 353 - YA WT 10&U Solid

## Instructions

1. Walk over poles and up to gate, work gate, left hand (10&Under do not work gate, walk through gate instead)
2. Jog over pole and into chute, back "L", walk out of chute and over poles
3. Jog over poles
4. Stop or break to walk, walk over poles
5. Jog between and over poles
6. Stop or break to walk, walk through serpentine and over poles
7. Jog over poles
8. Stop or break to walk, walk into box, execute 1 turn either direction, walk out of box and to exit

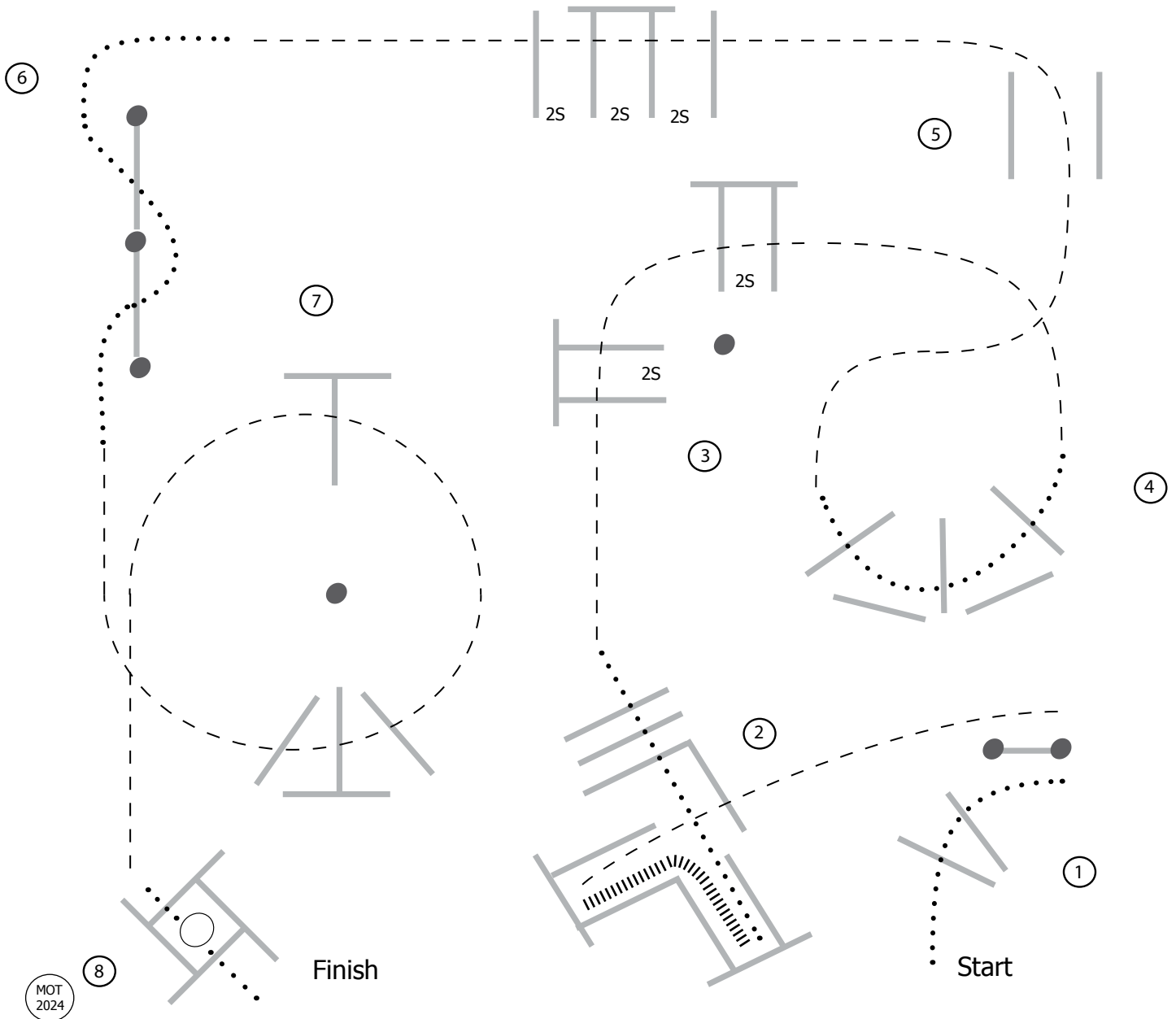

MOT 2024

Tim Kimura • Copyright 2024 • All Rights Reserved

Walk .....

Trot - - - -

Back |||||

# Trail

## Instructions

1. Jog over poles and up to gate, work gate, left hand
2. Jog over pole and into chute, back "L", walk out of chute and over poles
3. Jog over poles
4. Lope, right lead, over poles
5. Jog between poles then lope, left lead, over poles
6. Break to jog, jog through serpentine and over poles
7. Lope, left lead, over poles
8. Stop or break to walk, walk into box, execute 1 turn either direction, walk out of box and to exit

## Classes

- 343 - YA JR Western
- 344 - YA SR Western
- 345 - YA Jr Novice
- 346 - YA Sr Novice
- 347 - YA Jr Western Solid
- 348 - YA Sr Western Solid
- 349 - YA Novice Western Solid

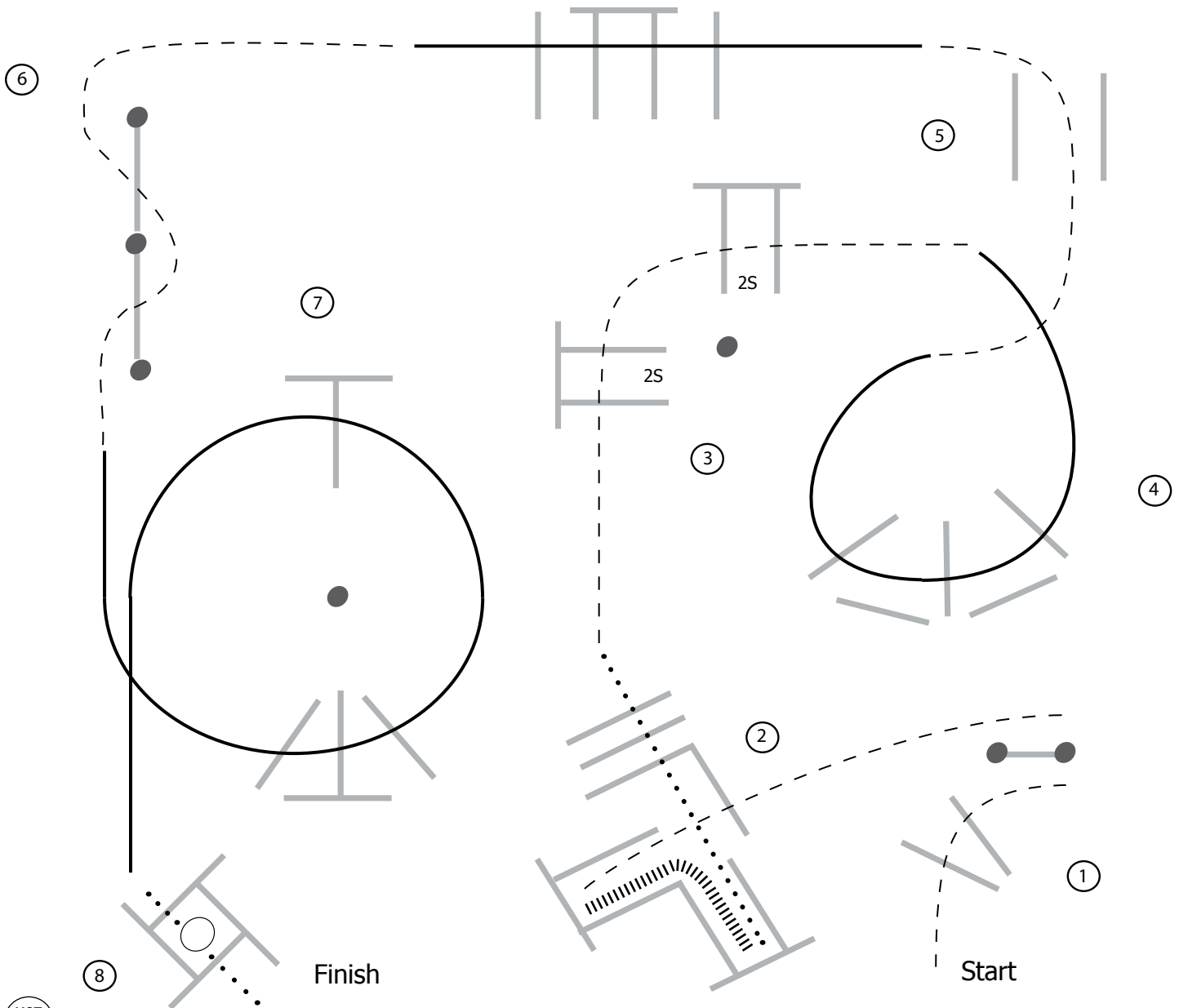

MOT  
2024

Tim Kimura • Copyright 2024 • All Rights Reserved

Walk ..... Jog - - - Lope — Back |||||



# Trail

## Classes

- 470 - AM JR Walk/Trot
- 471 - AM SR Walk/Trot
- 472 - AM Elite Walk/Trot
- 473 - AM Jr Walk/Trot Solid
- 474 - AM Sr/El Walk/Trot Solid

## Instructions

1. Jog over poles and around the cones
2. Stop or break to walk, walk into box, execute 1 turn either direction, walk out of box
3. Jog over poles
4. Stop or break to walk, walk over poles
5. Jog over poles
6. Jog over poles
7. Jog into chute, stop and back around corner and to gate
8. Work gate, right hand, walk to exit

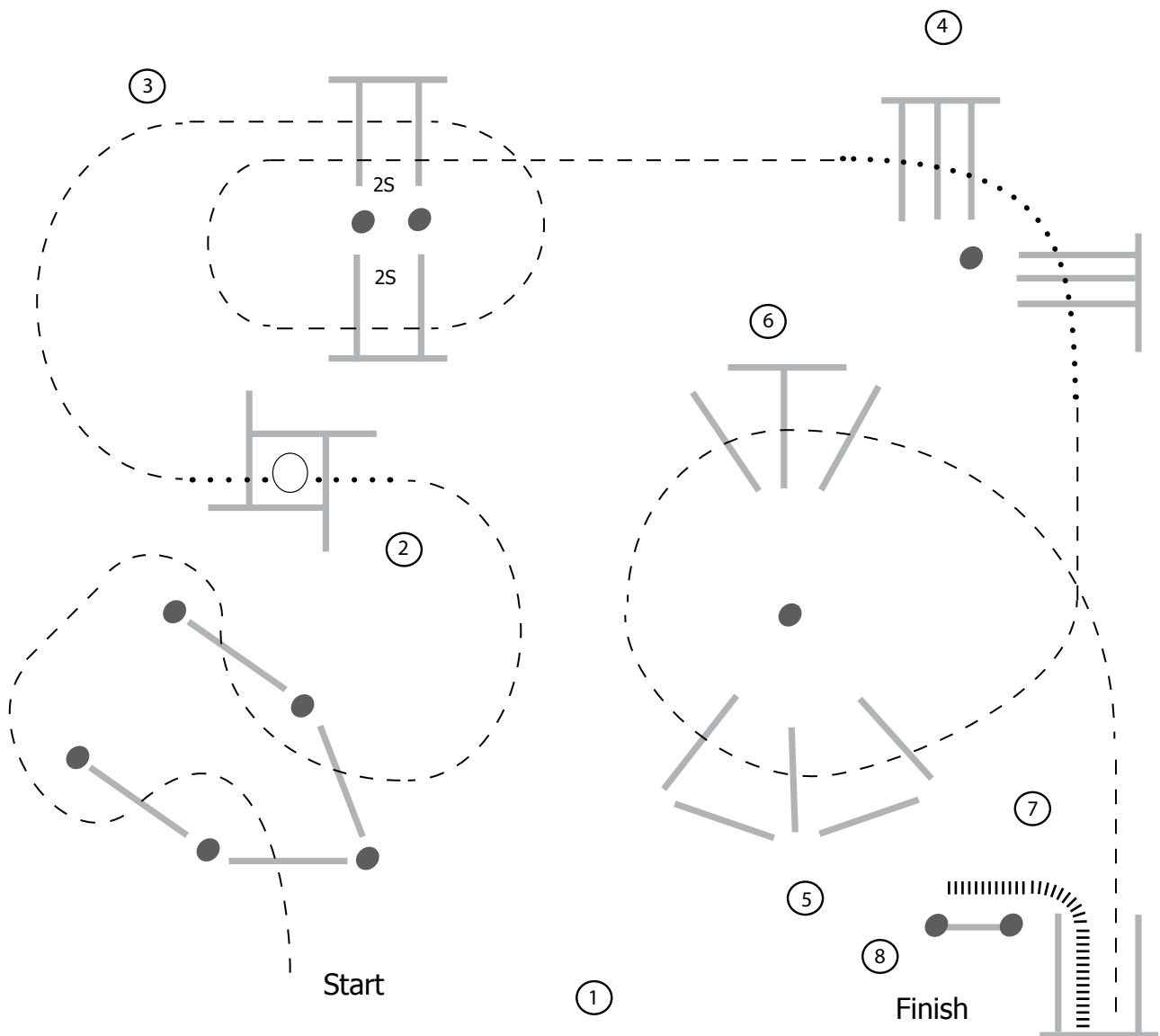

Tim Kimura • Copyright 2024 • All Rights Reserved

Walk .....

Trot - - -

Back |||||

# Trail

## Instructions

1. Jog over poles and around the cones
2. Stop or break to walk, walk into box, execute 1 turn either direction, walk out of box
3. Jog over poles, lope, right lead, over poles
4. Stop or break to walk, walk over poles
5. Lope, right lead, over poles
6. Break to jog, jog over poles
7. Jog into chute, stop and back around corner and to gate
8. Work gate, right hand, walk to exit

## Classes

475 - AM Novice Solid

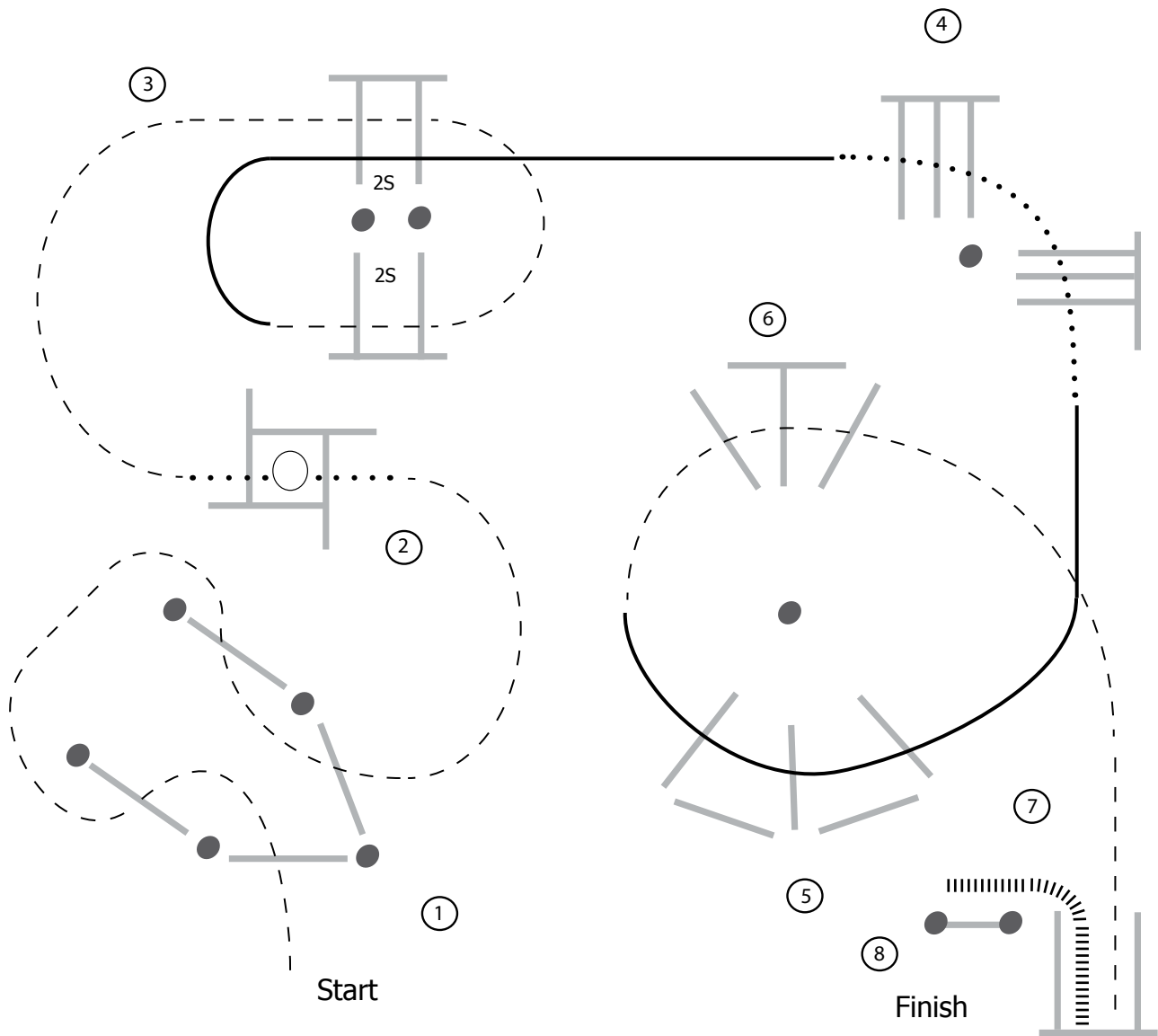

Tim Kimura • Copyright 2024 • All Rights Reserved

Walk ..... Jog - - - Lope — Back |||||

# Trail

## Classes

271 - YA Leadline W/T  
272 - YA Leadline W/T Solid

## Instructions

1. Walk up to gate, back from gate and around corner
2. Walk out of chute and over poles
3. Walk through serpentine and over poles
4. Jog over poles
5. Stop or break to a walk, walk over poles
6. Walk into box, execute 1 turn either direction, walk out of box
7. Jog over poles and to exit

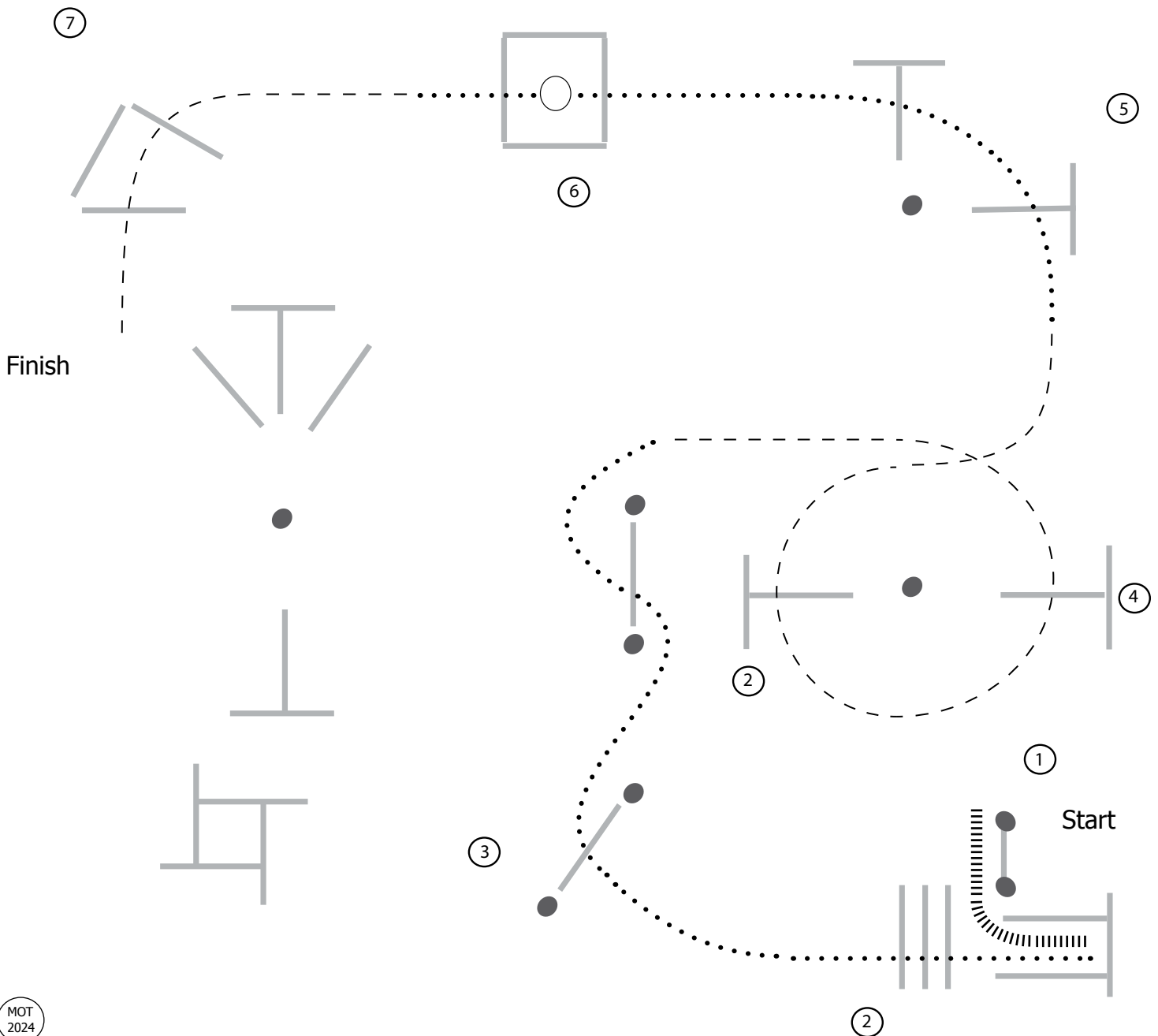

Tim Kimura • Copyright 2024 • All Rights Reserved

Walk .....

Back |||||

# Trail

## Instructions

1. Work gate, right hand, then back around corner and between poles, walk forward
2. Jog over poles
3. Lope, right lead, over poles
4. Break to jog, jog over poles
5. Lope, right lead, stop or break to walk, walk over poles
6. Lope, left lead, over poles
7. Break to jog, jog over poles
8. Stop or break to walk, walk into box, execute 1 turn either direction, walk out of box and to exit.

## Classes

- 414 - OP Green Western
- 415 - OP Green Western Solid
- 416 - AM Jr Western Solid
- 417 - AM Sr/El Western Solid
- 418 - OP Western 5&U
- 419 - OP Western 6&O
- 420 - OP Western 5&U Solid
- 421 - OP Western 6&O Solid

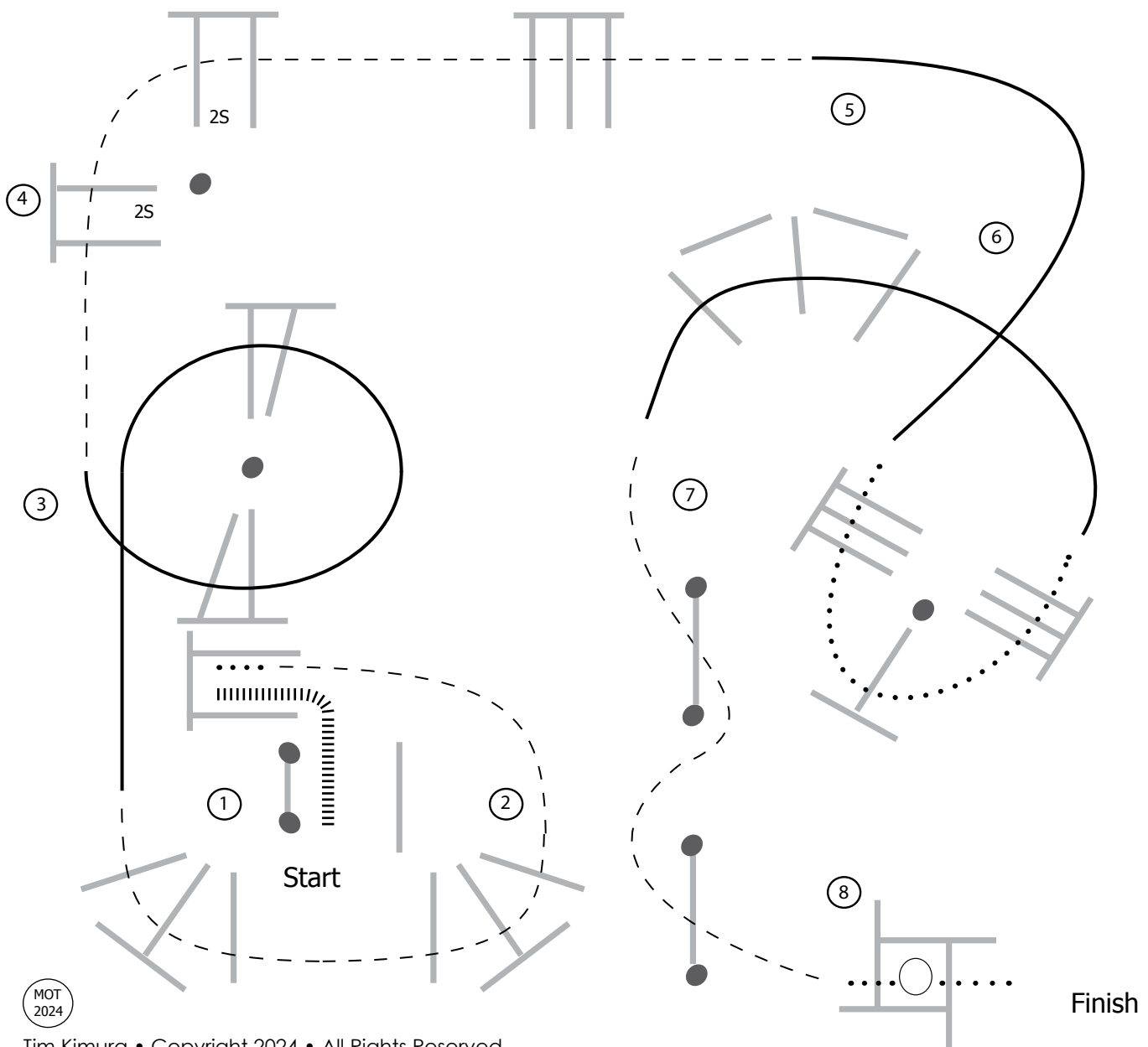

MOT  
2024

Tim Kimura • Copyright 2024 • All Rights Reserved

Walk ..... Jog - - - Lope — Back |||||

# Trail

## Classes

- 273 - YA Jr - English
- 274 - YA Sr - English
- 275 - YA - English, Solid
- 276 - AM Jr - English
- 277 - AM Sr - English
- 278 - AM Elite - English
- 279 - AM -English, Solid
- 280 - OP - English
- 281 - OP - English, Solid

## Instructions

1. Work gate, right hand
2. Back from gate and around corner
3. Walk out of chute and over pole
4. Trot through serpentine and over poles
5. Canter, right lead, over poles
6. Break to trot, trot over poles
7. Canter, left lead, over poles, break to trot
8. Stop or break to walk, walk into box, execute 1 turn either direction, walk out of box and to exit

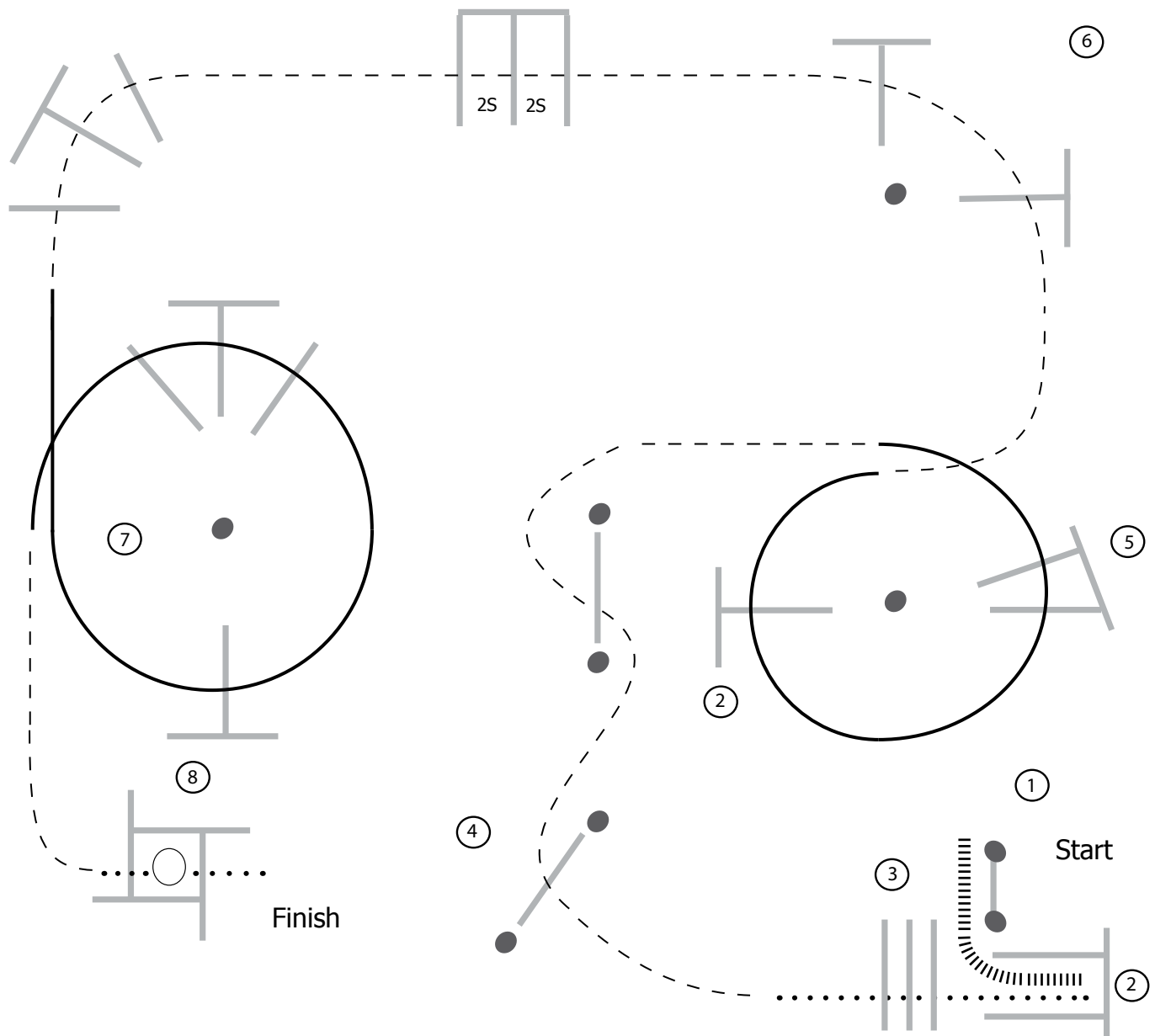

Tim Kimura • Copyright 2024 • All Rights Reserved

Walk ..... Trot - - Canter — Back |||||

# Trail

## Instructions

1. Walk into box, execute 1 turn, either direction, walk out of box
2. Jog through serpentine and over poles
3. Lope, right lead, over poles
4. Break to jog, jog over poles
5. Lope, left lead, over poles
6. Break to jog, jog over poles and up to gate, work gate, left hand
7. Sidepass right, back around corner and between poles
8. Walk out of chute and over poles to exit

## Classes

- 530 - AM Elite Western ST/HN
- 531 - AM SR Western ST/HN
- 532 - AM JR Western ST/HN
- 533 - AM Novice

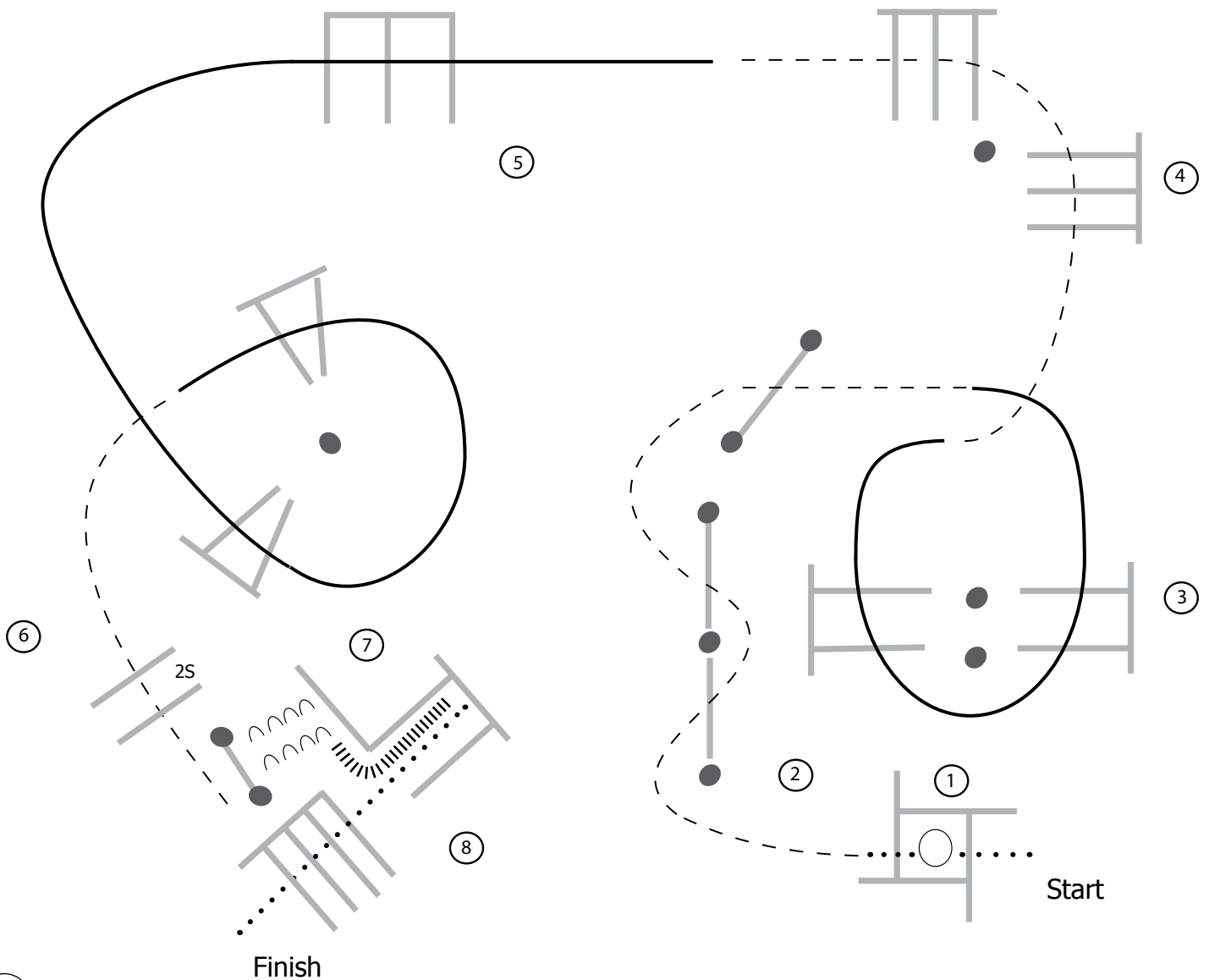

MOT  
2024

Tim Kimura • Copyright 2024 • All Rights Reserved

Walk ..... Jog - - - Lope — Back ||||| Sidepass 

# Ranch Trail

## Classes

- 27 - OP JR
- 28 - OP SR
- 29 - OP JR Solid
- 30 - OP SR Solid
- 31 - AM
- 33 - AM Solid
- 35 - YA
- 37 - YA Solid

## Instructions

1. Start at gate, work gate, right hand
2. Trot, then extend trot through serpentine and over log
3. Break to walk, walk over log and bridge, turn left sidepass left, walk over log
4. Lope, right lead, around corner and over logs
5. Extend lope around corner, change leads (simple or flying), collect lope and lope around corner
6. Break to trot, trot over logs and into chute, stop
7. Back between logs and around corner
8. Walk out of chute and over logs
9. Trot up to drag, work drag at walk or trot, return drag and trot to exit. (Youth do not drag log, instead, pick up object, trot around cone, return object then trot to exit)

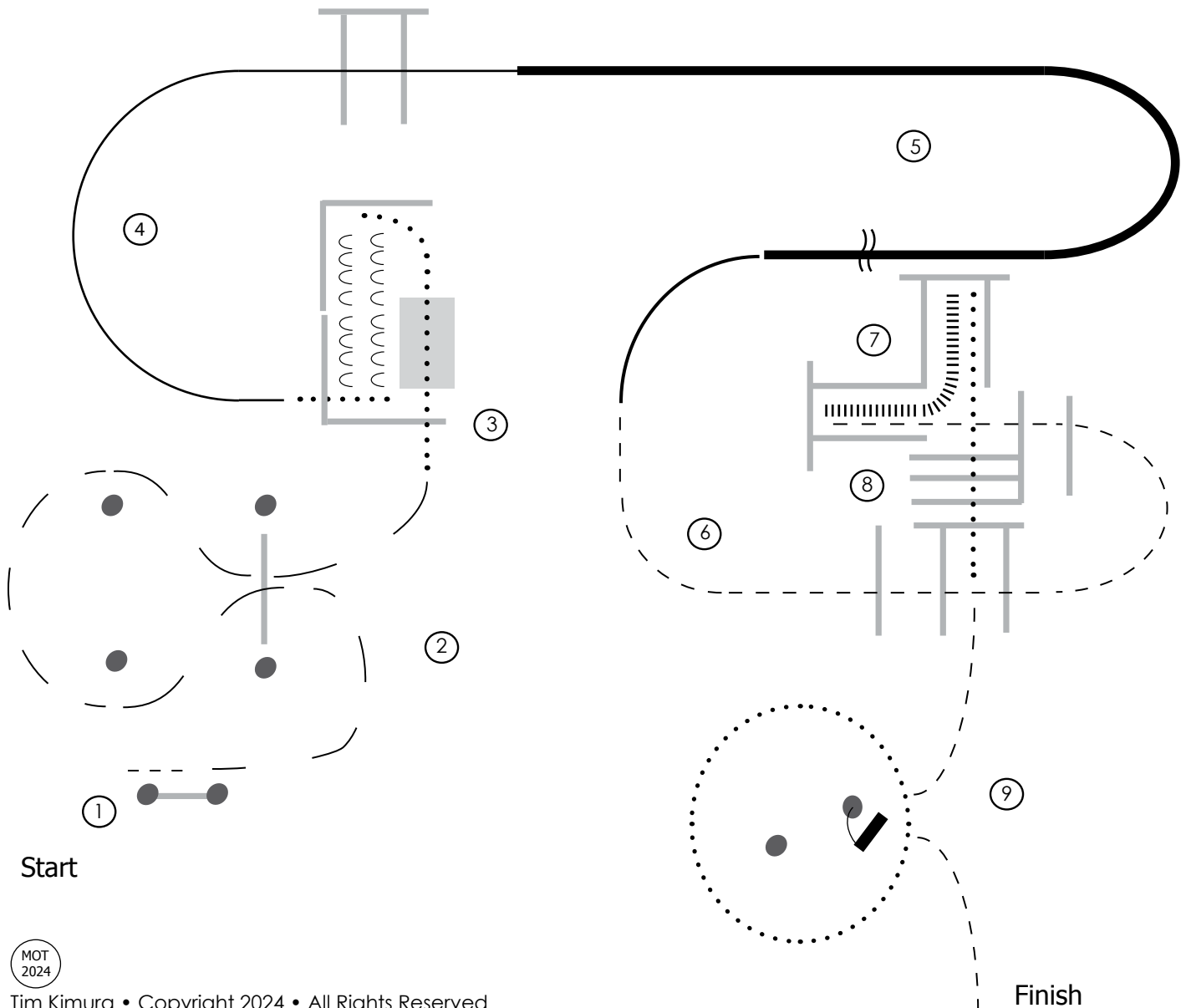

Tim Kimura • Copyright 2024 • All Rights Reserved

Walk ..... Back |||||

Trot - - -

Ext. trot — — —

Lope ——— Ext. Lope ———

Sidepass ^^^^

Change leads } }

# Ranch Trail

## Instructions

1. Start at gate, work gate, right hand
2. Trot through serpentine and over log
3. Break to walk, walk over log and bridge, turn left sidepass left, walk over log
4. Trot around corner and over logs
5. Extend trot around corner, through middle and around corner
6. Collect trot over logs and into chute, stop
7. Back between logs and around corner
8. Walk out of chute and over logs
9. Trot up to drag, work drag at walk or trot, return drag and trot to exit. (Youth do not drag log, instead, pick up object, trot around cone, return object then trot to exit)

## Classes

- 32 - AM Walk/Trot
- 34 - AM Walk/Trot Solid
- 36 - YA Walk/Trot 11-18
- 38 - YA Walk/Trot 11-18 Solid

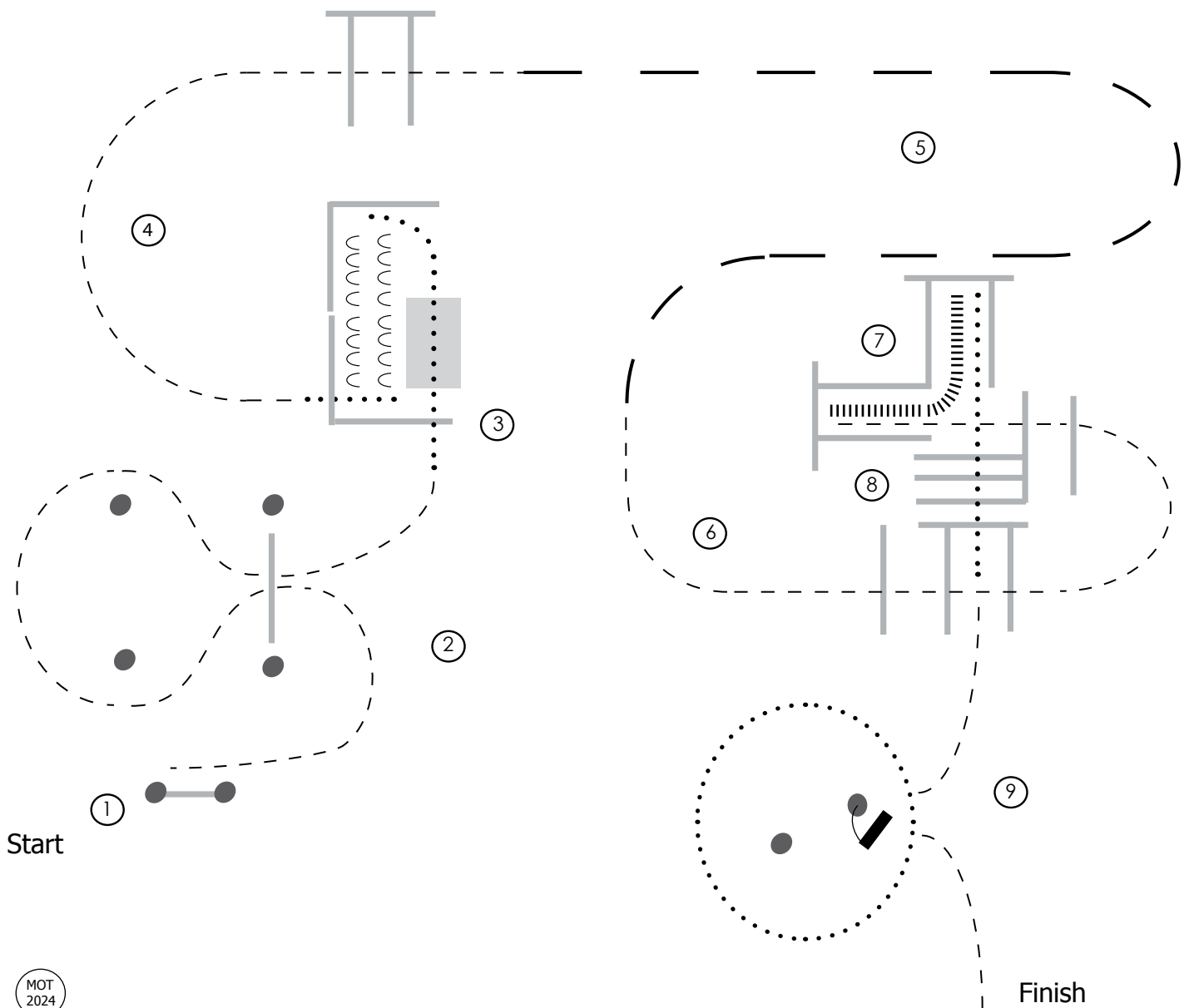

Tim Kimura • Copyright 2024 • All Rights Reserved

Walk .....

Trot - - -

Ext. trot — —

Back |||||

Sidepass ^ ^ ^ ^  
^ ^ ^ ^



# Obstacle Driving

## Classes

- 643 - OP Miniature
- 644 - OP B Miniature
- 645 - OP Solid Mini/B Mini
- 646 - YA Mini/B Mini
- 647 - AM Mini/B Mini
- 648 - AM Pony
- 649 - OP Pony

## Instructions

1. Trot through cones
2. Drive through "U" at the walk
3. Walk up to and pick up object, then trot around center cone, drop off object in original location
4. Walk up, turn and back to knock off pole
5. Walk forward then drive between poles at the trot
6. Stop or break to walk, walk over plywood on the ground
7. Walk up to and then position wheel and keep left wheel between poles while walking forward

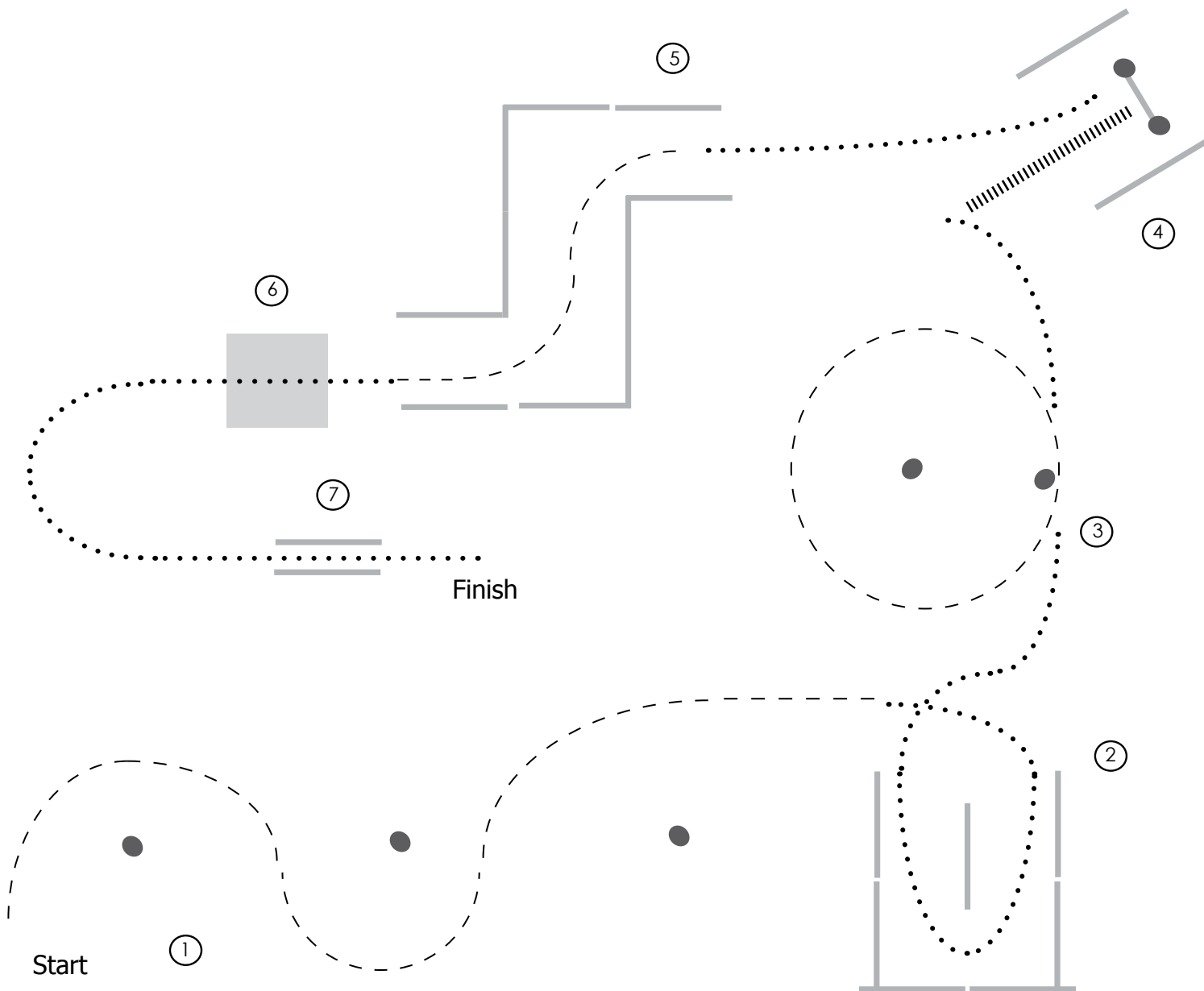

Tim Kimura • Copyright 2024 • All Rights Reserved

Walk .....

Trot - - -

Strong Trot — —

Back |||||

# Reinsmanship

## Instructions

1. Working trot
2. Stop
3. Execute ½ turn left
4. Walk
5. Slow trot circle
6. Strong trot
7. Working trot
8. Stop, back one horse length, walk to exit

## Classes

- 270 - YA Horse
- 120 - AM Horse
- 720 - AM Pony/Mini/B Mini
- 721 - YA Pony/Mini/B Mini

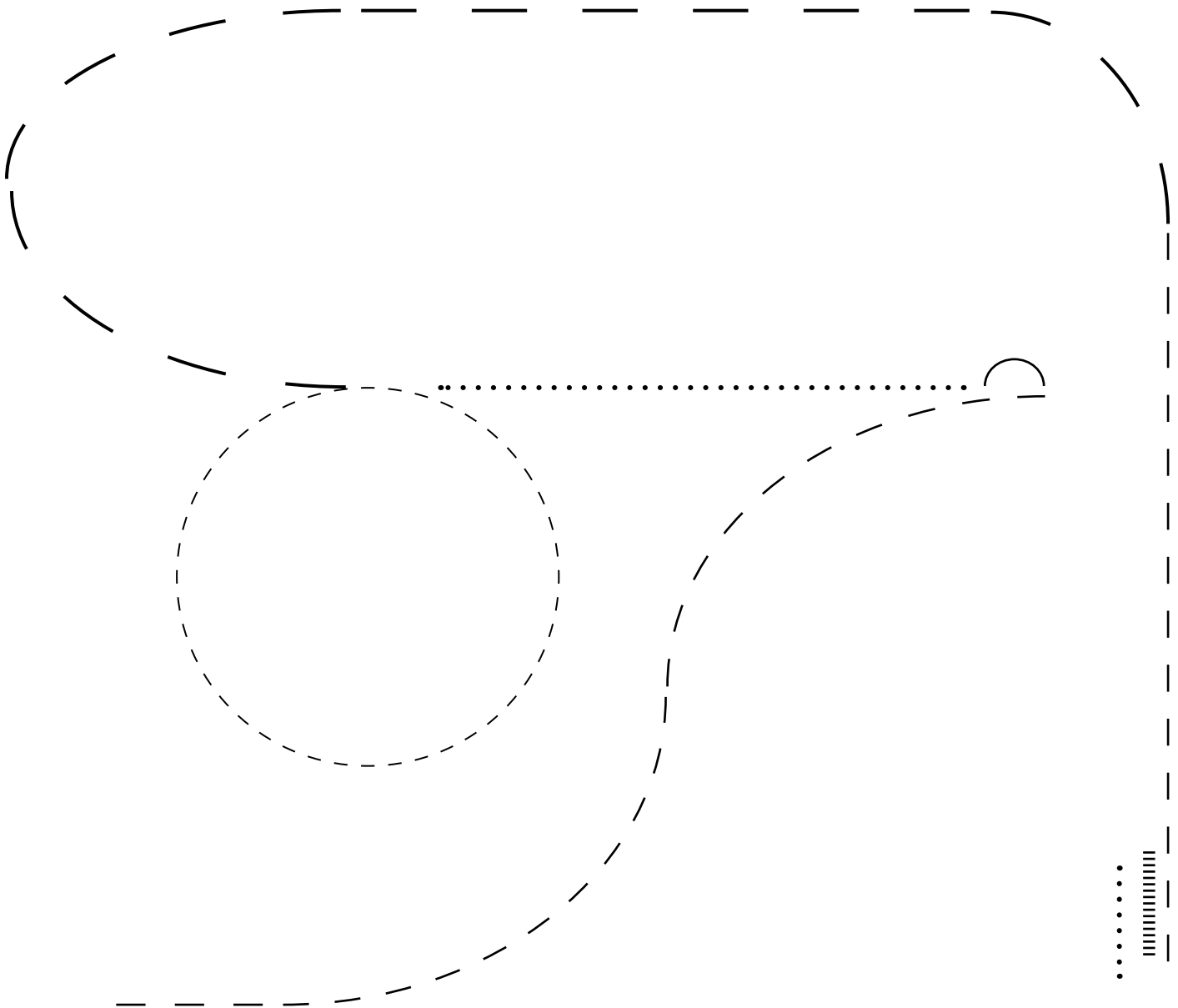

Walk ..... Slow Trot - - - Working Trot - - Strong Trot — — Back |||||

# Halter

Ring stewards will direct exhibitors in all halter classes. The patterns below are only meant to give exhibitors a general idea of the class procedure. After pattern is complete, ring stewards will line exhibitors up head to tail to be inspected. Exception: pleasure and saddle types will stand for inspection prior to trotting away from judges.

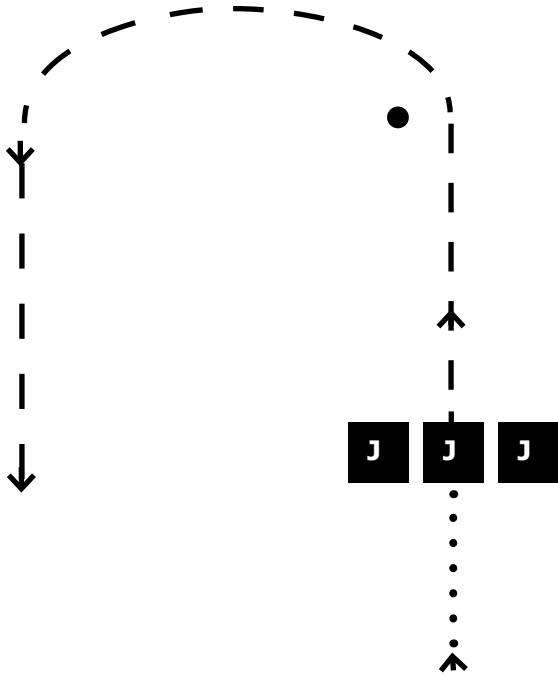

Stock Type

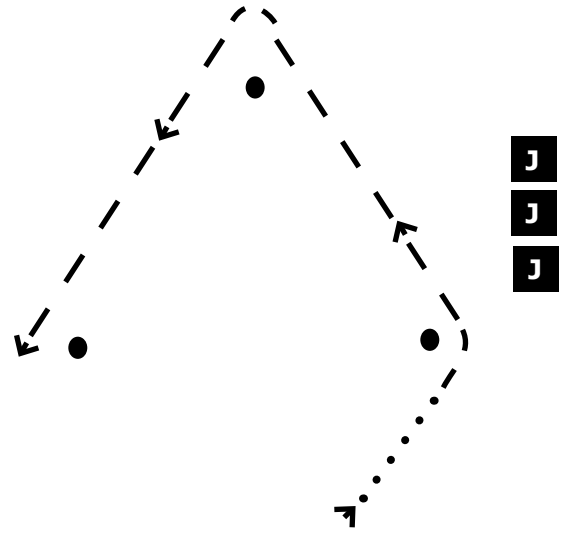

Hunter Type

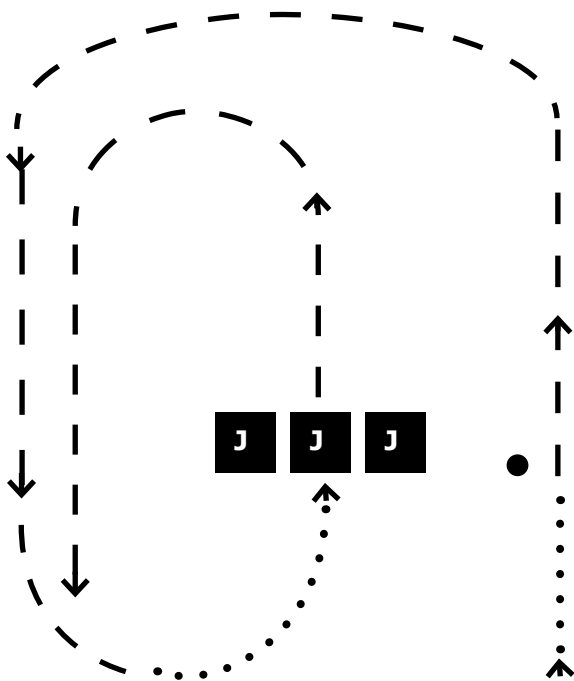

Miniature

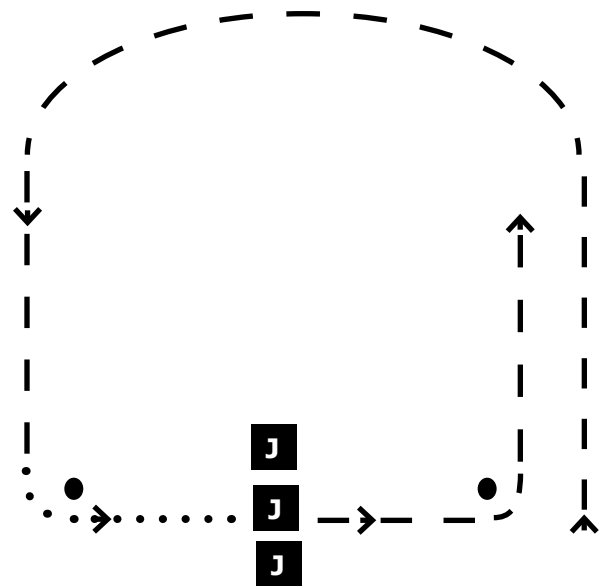

Pleasure and Saddle Type

# 2024 PINTO WORLD CHAMPIONSHIP

## PtHA



# CORPORATE PARTNERS

## DIAMOND SPUR



TULSA  
CONVENTION &  
VISITORS BUREAU

## GOLD SPUR



**BILL KNIGHT**  
FORD



HYATT  
REGENCY<sup>®</sup>  
TULSA



EMBASSY SUITES

## SILVER SPUR

Wrangler



KELLY HERD  
FINE JEWELRY SINCE 1983



STATE LINE TACK<sup>®</sup>  
We make riding affordable.



## BRONZE SPUR

  
PURINA



**BOOT  
BARN<sup>®</sup>**

Top Quality. Great Value.  
**PERRI'S**  
WWW.PERRISLEATHER.COM

## STEEL SPUR

Arena<sup>™</sup>  
Werks

THE EQUINE  
**CHRONICLE<sup>®</sup>**



**BETTER  
HORSES**

 **PRIME PERFORMANCE**  
nutrition