

# PATTERN BOOK



**PINTO WORLD CHAMPIONSHIP SHOW®**  
**JUNE 6-20, 2026**  
**BUILT FORD TOUGH LIVESTOCK COMPLEX**  
**TULSA, OKLAHOMA**



# TABLE OF CONTENTS

---

Bareback English Equitation .....	20
Bareback Western Horsemanship. ....	21
English Equitation .....	15
English Showmanship .....	2
Halter.....	60
Hunter Over Fences In-Hand .....	58
Hunter Hack.....	57
Jumping In-Hand .....	59
Obstacle Driving .....	31
Ranch Horsemanship.....	27
Ranch Reining.. ....	38
Ranch Riding....	35
Ranch Trail.....	54
Reinsmanship.....	30
Trail.....	42
Trail in Hand.....	39
Western Horsemanship .....	22
Western Riding.....	32
Western Showmanship.....	7
Ranch Showmanship.....	12





# English Showmanship

## Classes

61 - YA Jr Novice - English Showmanship, Horse/Pony  
 65 - YA W/T, 11 - 18 - Eng Showmanship, Horse/Pony  
 66 - YA W/T, 11 - 18 - Eng Showmanship, Solid Horse/Pony  
 235 - AM Novice - English Showmanship, Horse

## Instructions

1. Walk, stop
2. Execute 1 turn
3. Trot
4. Walk, stop
5. Set up
6. Inspection
7. Back one horse length
8. Execute 3/4 turn
9. Walk, trot
10. Stop, hesitate briefly, walk to exit

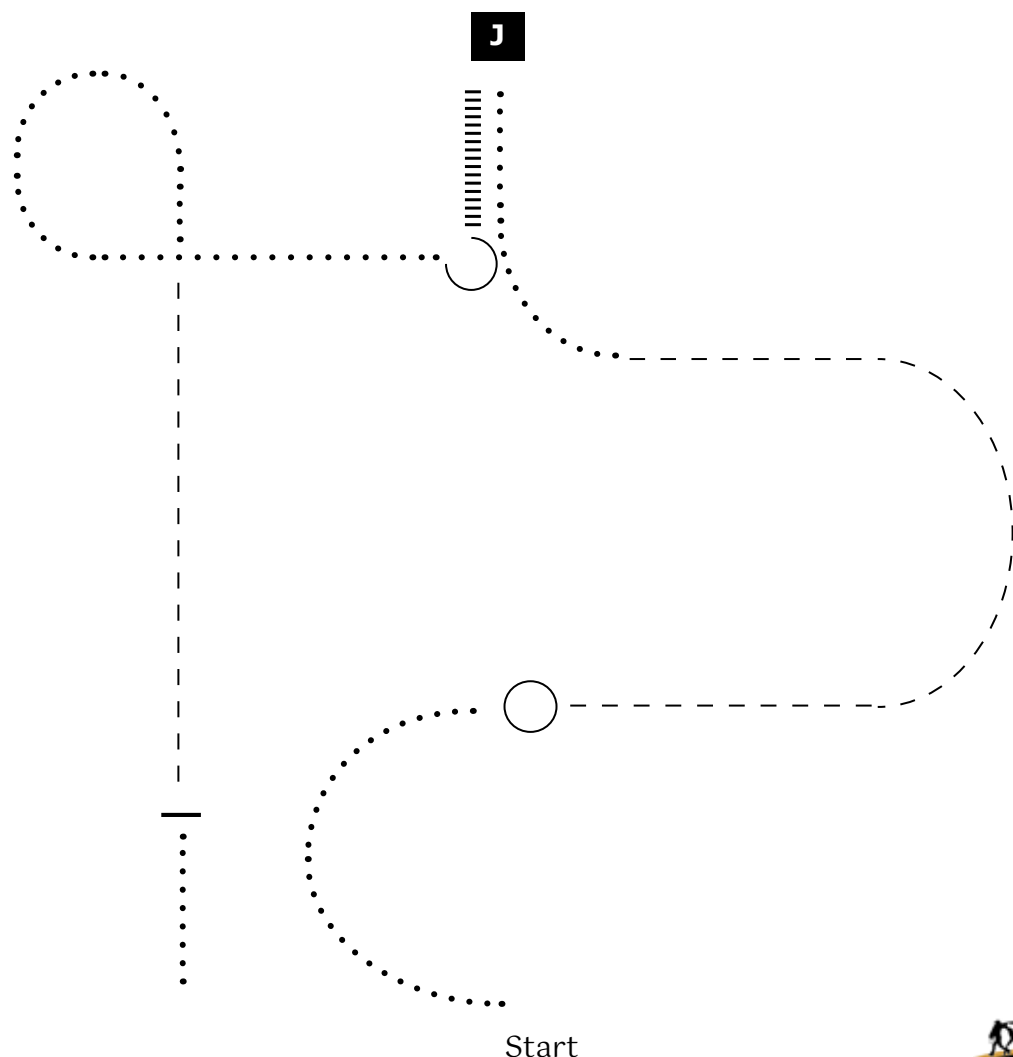

Walk    . . . . .

Trot    - - - - -

Back    |||||

Judge    **J**



# English Showmanship

## Classes

- 59 - YA Jr - English Showmanship, Horse/Pony
- 62 - YA Sr Novice - English Showmanship, Horse/Pony
- 63 - YA Jr - English Showmanship, Solid Horse/Pony
- 231 - AM Sr/El - English Showmanship, Solid Horse
- 233 - AM Sr - English Showmanship, Horse
- 234 - AM Elite - English Showmanship, Horse

## Instructions

1. Walk, stop
2. Execute 1 turn
3. Trot, stop
4. Set up
5. Inspection
6. Back two horse lengths
7. Execute  $\frac{3}{4}$  turn
8. Walk
9. Trot
10. Stop, hesitate briefly, walk to exit

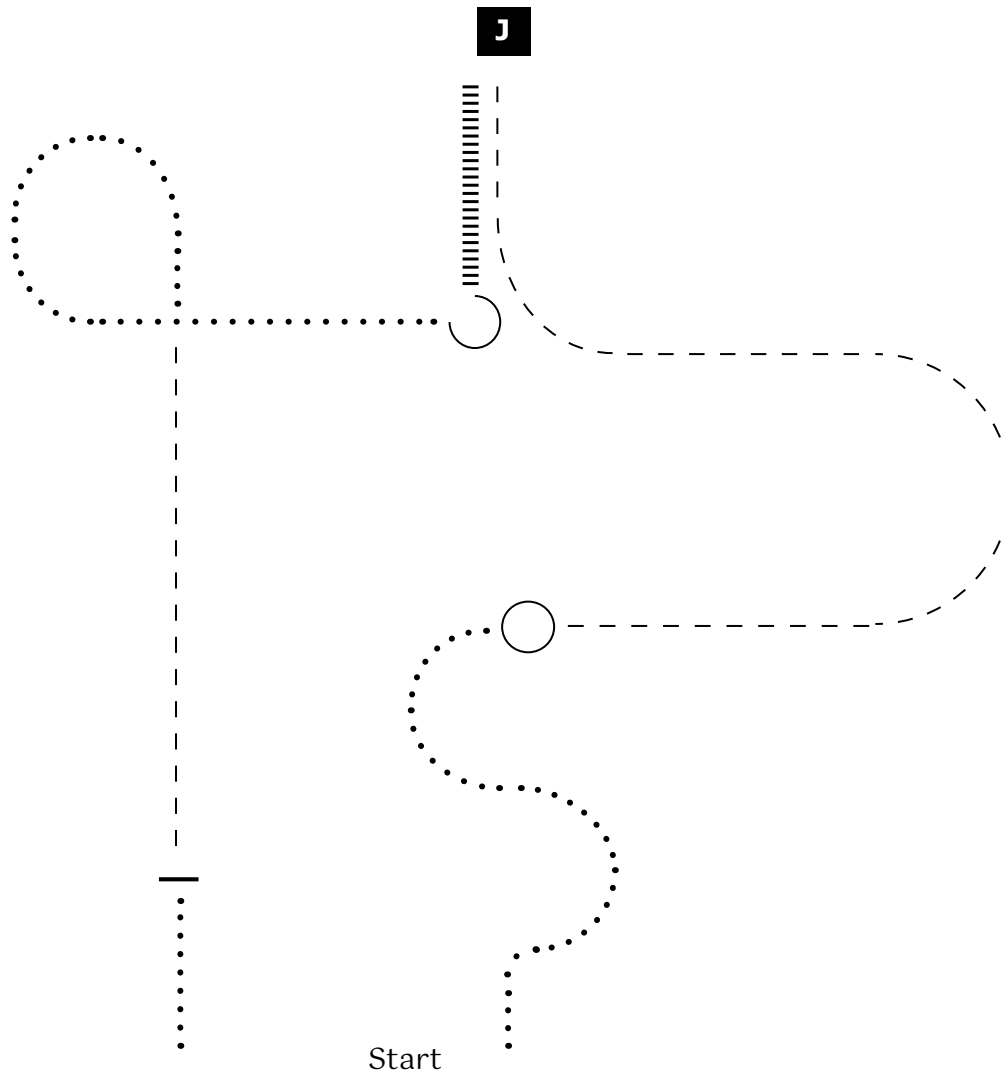

Walk .....

Trot - - - -

Back |||||

Judge **J**





# Western Showmanship

Classes	Instructions
623 - AM Jr Walk/Trot - Western Showmanship, Horse 624 - AM Sr Walk/Trot - Western Showmanship, Horse 625 - AM El Walk/Trot - Western Showmanship, Horse 637 - AM Jr W/T - Western Showmanship, Solid Horse 638 - AM Sr/El W/T - Western Showmanship, Solid Horse 733 - AM W/T - Western Showmanship, Mini/B Mini/Pony	1. Walk, stop 2. Back one horse length 3. Execute ½ turn 4. Walk, stop 5. Set up 6. Inspection 7. Execute ½ turn 8. Walk, stop 9. Execute 1 turn 10. Walk to exit

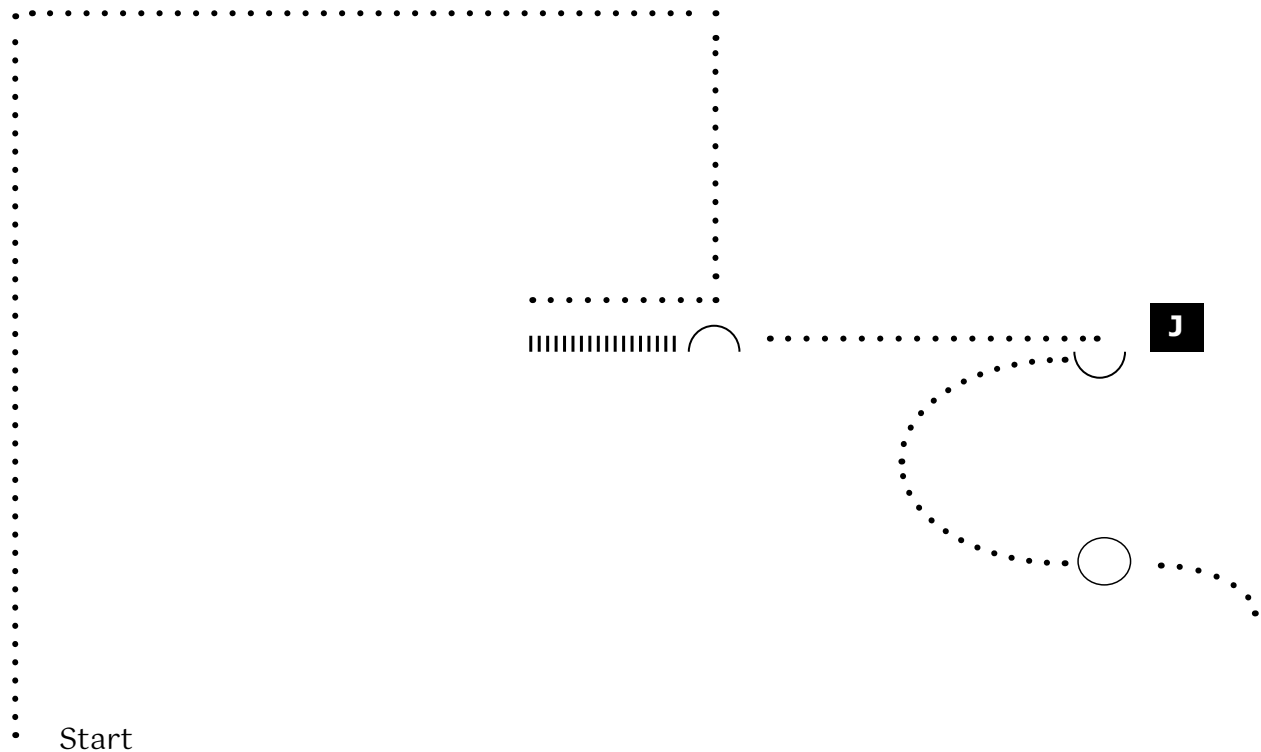

Walk    . . . . .

Back    |||||

Judge    **J**





# Western Showmanship

## Classes

484 - YA Jr Novice - Western Showmanship, Horse/Pony  
 488 - YA W/T, 11 - 18 - Western Showmanship, Hrse/Pony  
 585 - YA W/T, 11-18 - Western Showmanship, Sld Hrse/Pny  
 589 - YA Novice - Western Showmanship, Solid Hrse/Pny  
 622 - AM Novice - Western Showmanship, Horse  
 636 - AM Novice - Western Showmanship, Solid Horse  
 734 - AM - Western Showmanship, Mini/B Mini/Pony  
 737 - YA - Western Showmanship, Mini/B Mini/Pony

## Instructions

1. Trot, walk, trot
2. Stop. back two horse lengths
3. Execute ½ turn
4. Trot, walk, stop
5. Set up
6. Inspection
7. Execute ½ turn
8. Walk, stop
9. Execute 1 turn
10. Trot to exit

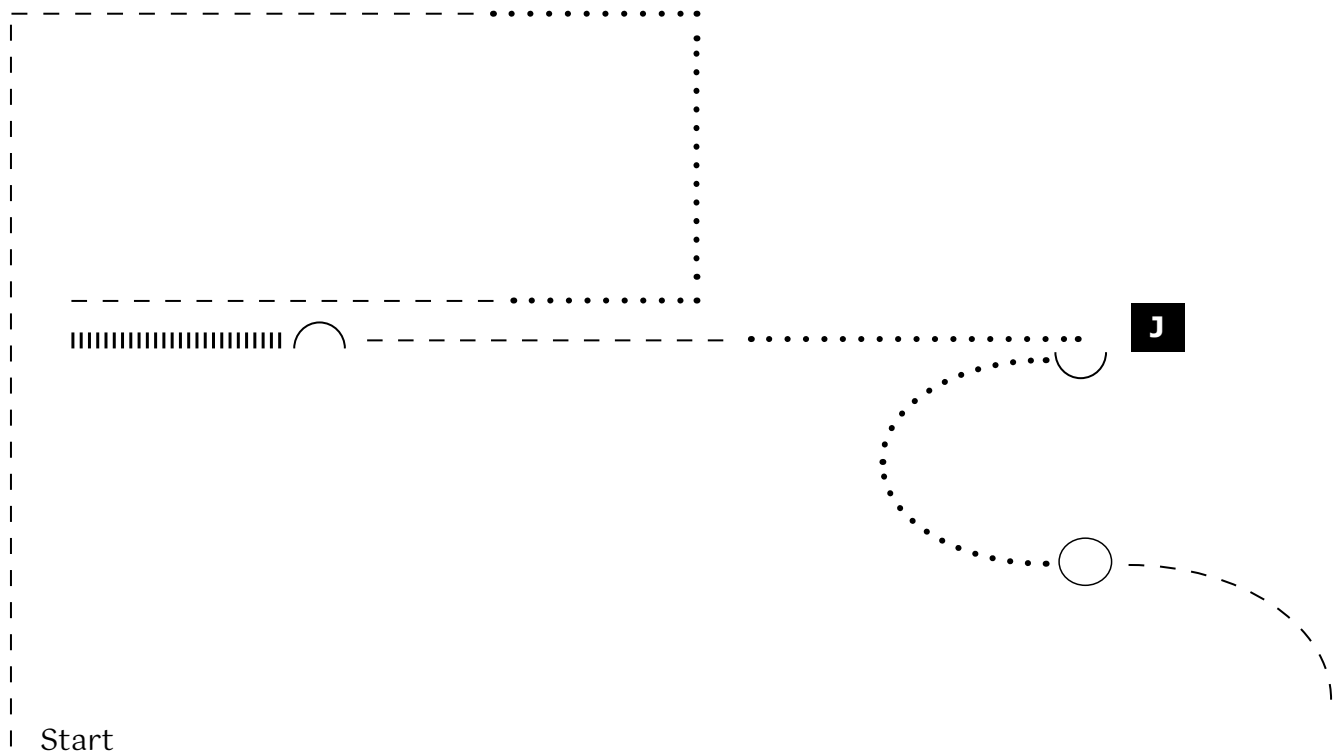

Walk    •••••    Trot    - - - -    Back    |||||

Judge    **J**



# Western Showmanship

## Classes

485 - YA Sr Novice - Western Showmanship, Horse/Pony  
 486 - YA Jr - Western Showmanship, Horse (NSBA)  
 587 - YA Jr - Western Showmanship, Solid Horse/Pony (NSBA)  
 620 - AM Sr - Western Showmanship, Horse (NSBA)  
 621 - AM Elite - Western Showmanship, Horse (NSBA)  
 635 - AM Sr/El - Western Showmanship, Solid Horse (NSBA)

## Instructions

1. Trot, walk, trot, stop
2. Back one horse length, execute ½ turn, back one horse length
3. Trot, walk, stop
4. Set up
5. Inspection
6. Execute ½ turn
7. Walk, stop
8. Execute 1 turn
9. Trot to exit

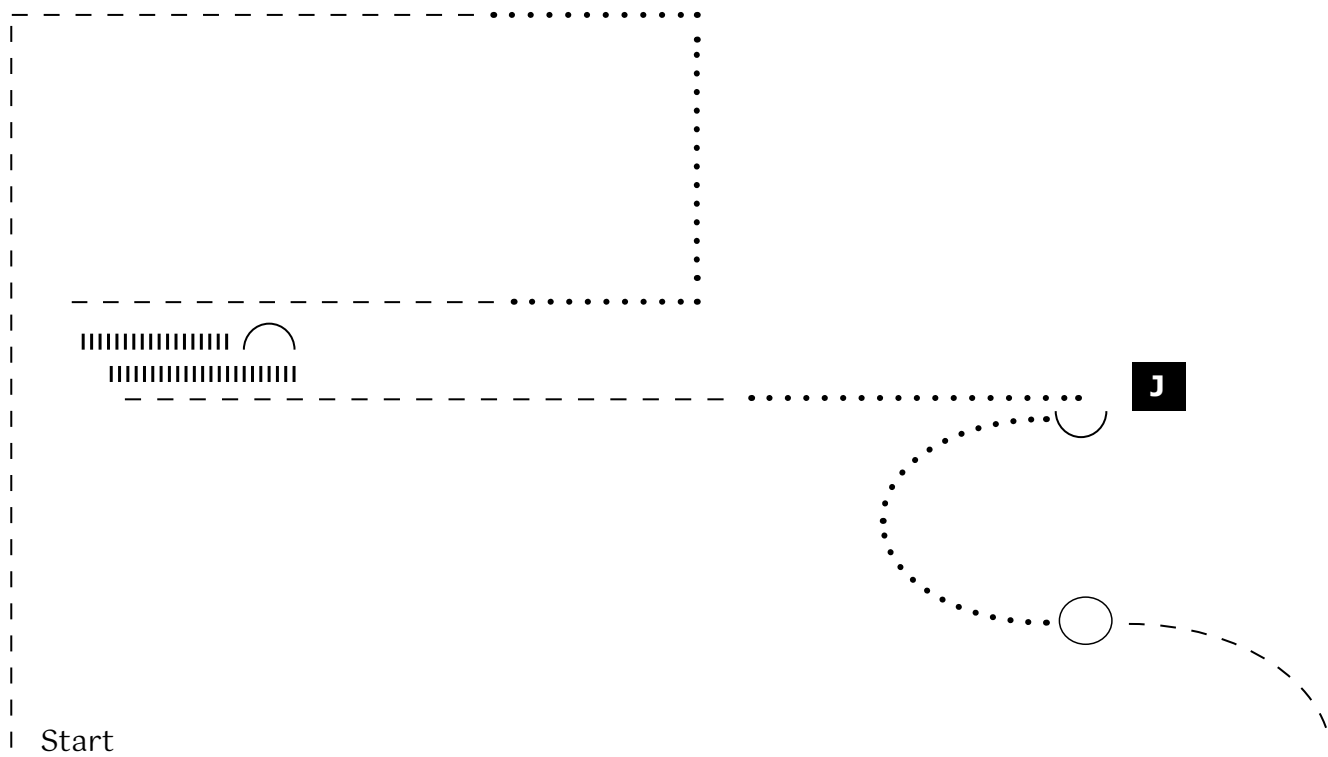

Walk    •••••    Trot    - - - -    Back    |||||

Judge    **J**



# Western Showmanship

Classes	Instructions
487 - YA Sr - Western Showmanship, Horse (NSBA) 588 - YA Sr - Western Showmanship, Solid Horse/Pony (NSBA) 619 - AM Jr - Western Showmanship, Horse (NSBA) 634 - AM Jr - Western Showmanship, Solid Horse (NSBA)	1. Trot, walk, trot, stop 2. Back one horse length, execute ½ turn, back one horse length 3. Trot, walk, stop 4. Execute ½ turn 5. Set up 6. Inspection 7. Trot, stop 8. Execute 1 turn 9. Walk to exit

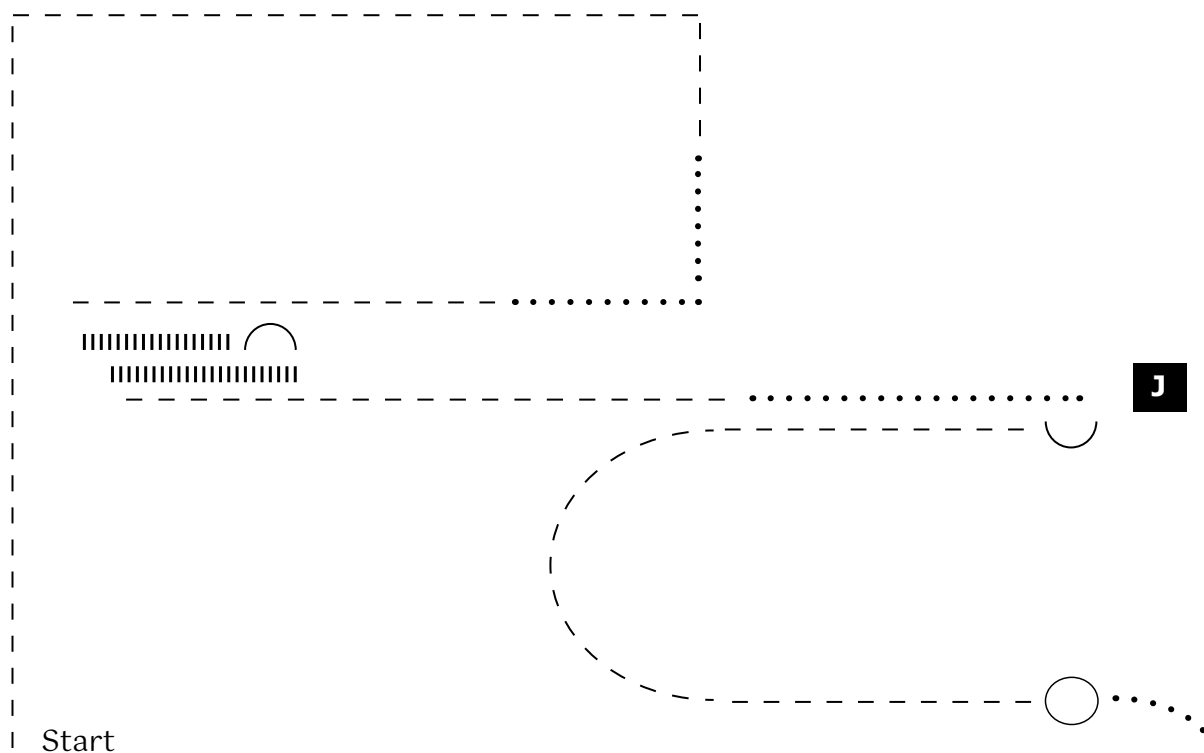

Walk ..... Trot - - - - Back ||||| Judge **J**



# Ranch Showmanship

## Classes

46 - AM Walk/Trot - Ranch Showmanship Horse  
 48 - AM Walk/Trot - Ranch Showmanship, Solid Horse

## Instructions

1. Walk, stop
2. Execute 1 turn
3. Walk, stop
4. Set up
5. Inspection
6. Back at least one horse length
7. Walk, stop
8. Back at least one horse length
9. Walk to exit

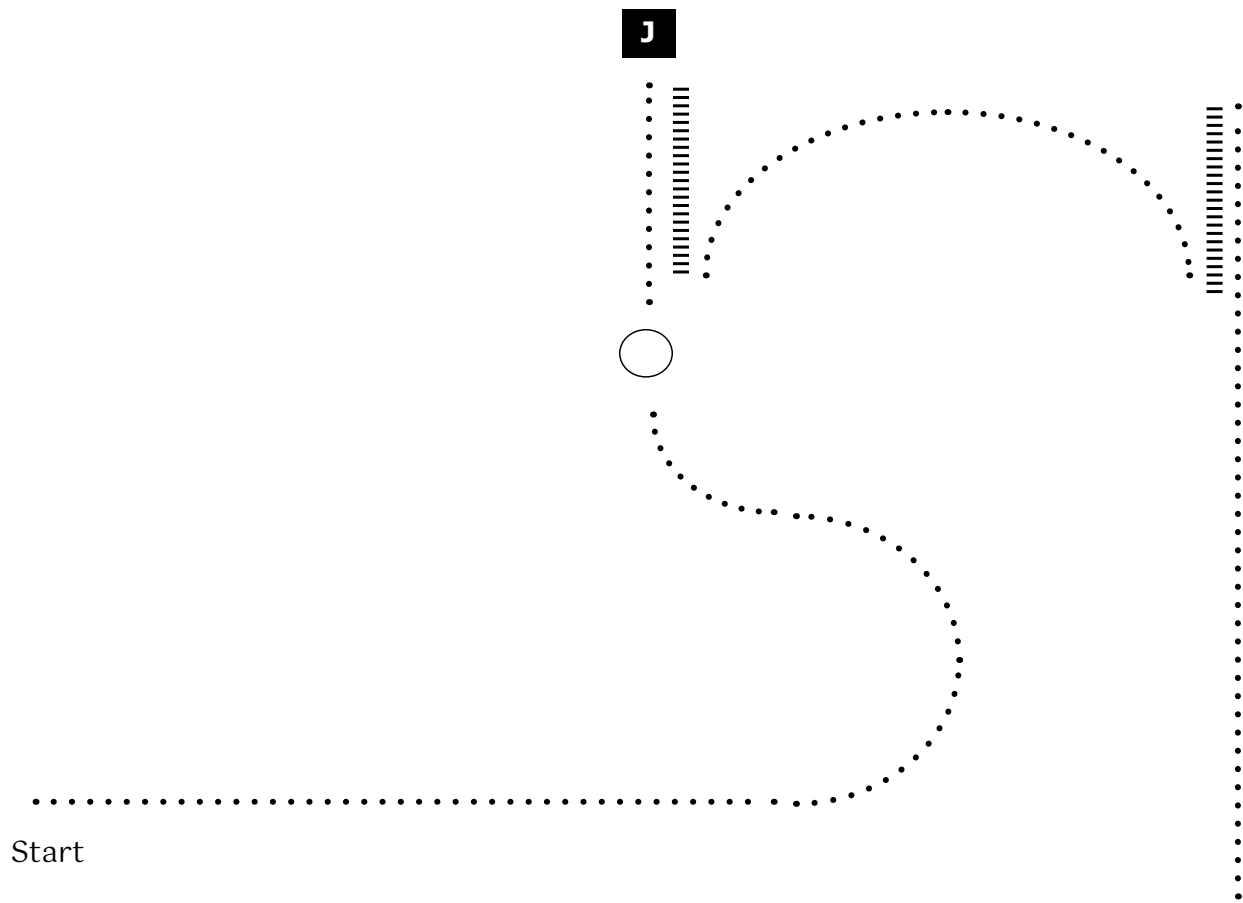

Walk    .....   

Back    |||||

Judge    **J**



# Ranch Showmanship

## Classes

- 39 - YA Walk/Trot 11- 18 - Ranch Showmanship Horse/Pony
- 40 - YA Walk/Trot 10&u - Ranch Showmanship Hrse/Pony
- 42 - YA Walk/Trot 11-18 - Ranch Showmanship, Solid Hrse/Pny
- 43 - YA Walk/Trot 10&u - Ranch Showmanship, Solid Hrse/Pny

## Instructions

1. Walk, trot, stop
2. Execute 1 turn
3. Walk, stop
4. Set up
5. Inspection
6. Back at least one horse length
7. Walk, stop
8. Back at least one horse length
9. Trot to exit

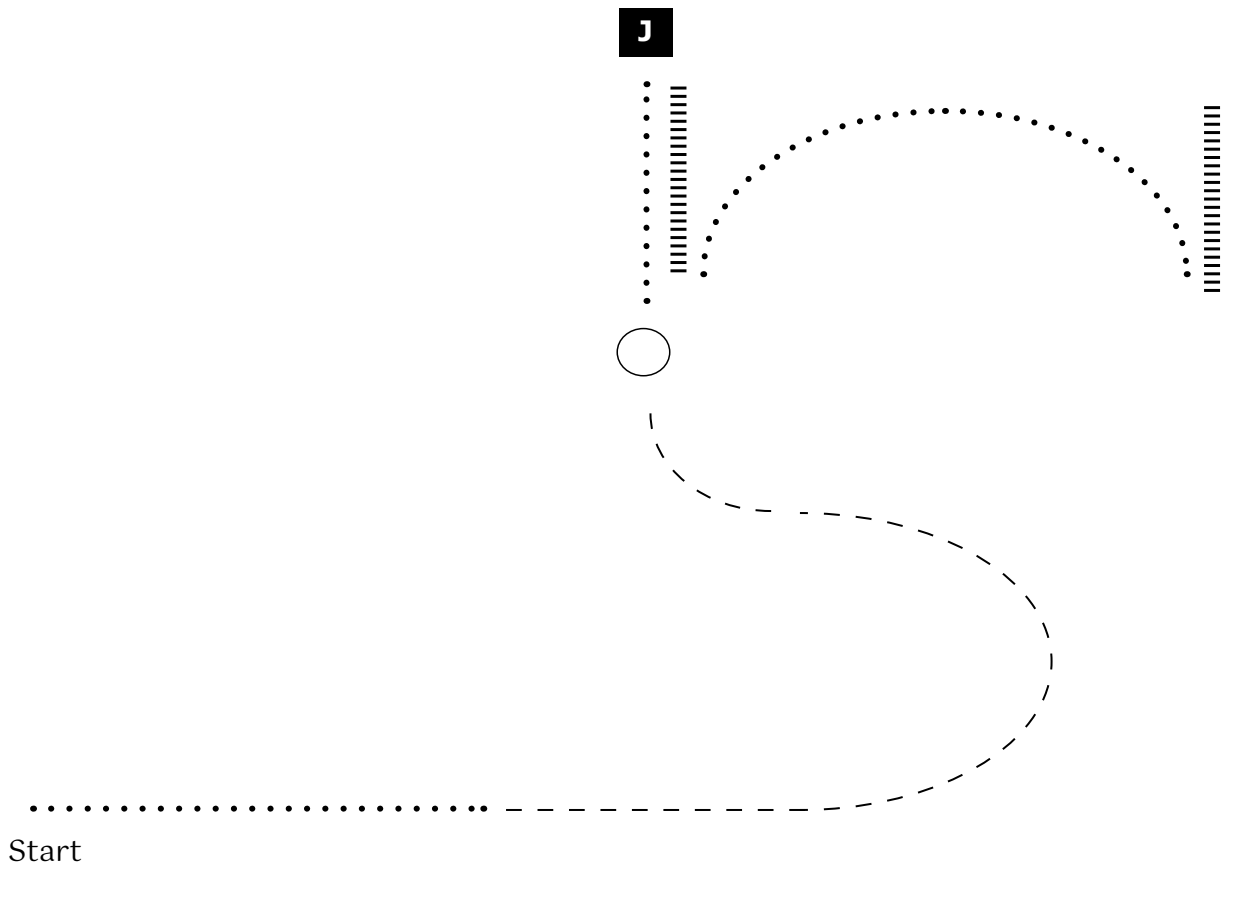

Walk    .....   

Trot    - - - -   

Back    |||||   

Judge    **J**



# Ranch Showmanship

## Classes

- 41 - YA - Ranch Showmanship Horse/Pony
- 44 - YA Jr- Ranch Showmanship, Solid Horse/Pony
- 45 - YA Sr- Ranch Showmanship, Solid Horse/Pony
- 47 - AM - Ranch Showmanship Horse
- 49 - AM Jr - Ranch Showmanship, Solid Horse
- 50 - AM Sr/El - Ranch Showmanship, Solid Horse

## Instructions

1. Walk, stop, hesitate briefly
2. Trot, stop
3. Set up
4. Inspection
5. Back at least one horse length
6. Walk, stop
7. Back at least one horse length
8. Execute 1 turn
9. Trot to exit

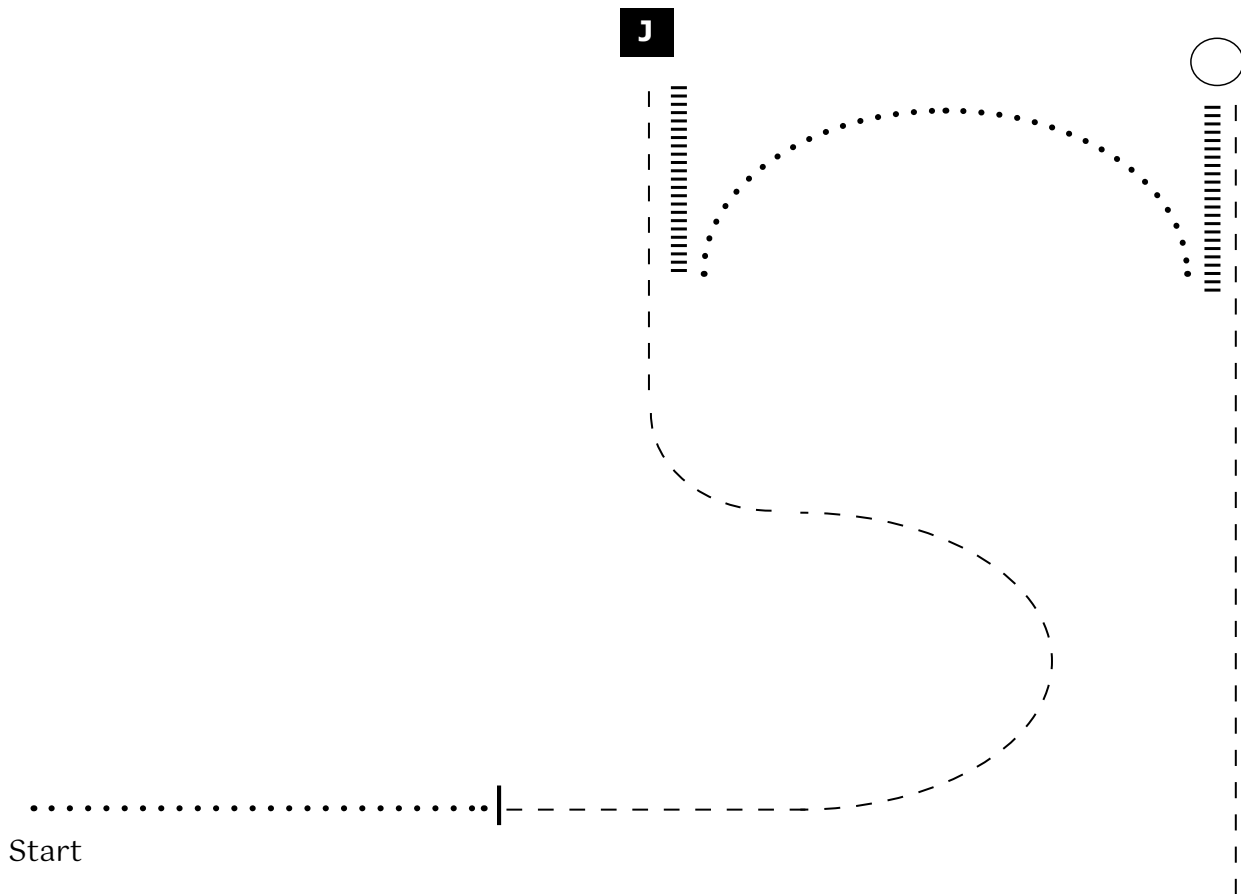

Walk ..... Trot - - - - Back |||||

Judge **J**



# English Equitation

## Classes

- 122 - YA Leadline Walk/Trot, 8 & u - Hunt Seat Equitation
- 123 - YA Leadline Walk/Trot, 8 & u - Hunt Seat Equitation, Solid
- 124 - YA Walk/Trot, 10 & u - Hunt Seat Equitation, Horse/Pony
- 126 - YA Walk/Trot, 10 & u - Hunt Seat Equitation, Solid Horse/Pony

## Instructions

1. Walk
2. Sitting trot
3. Trot
4. Sitting trot, stop
5. Back one horse length
6. Execute ¼ turn right on the forehand
7. Walk
8. Trot to exit

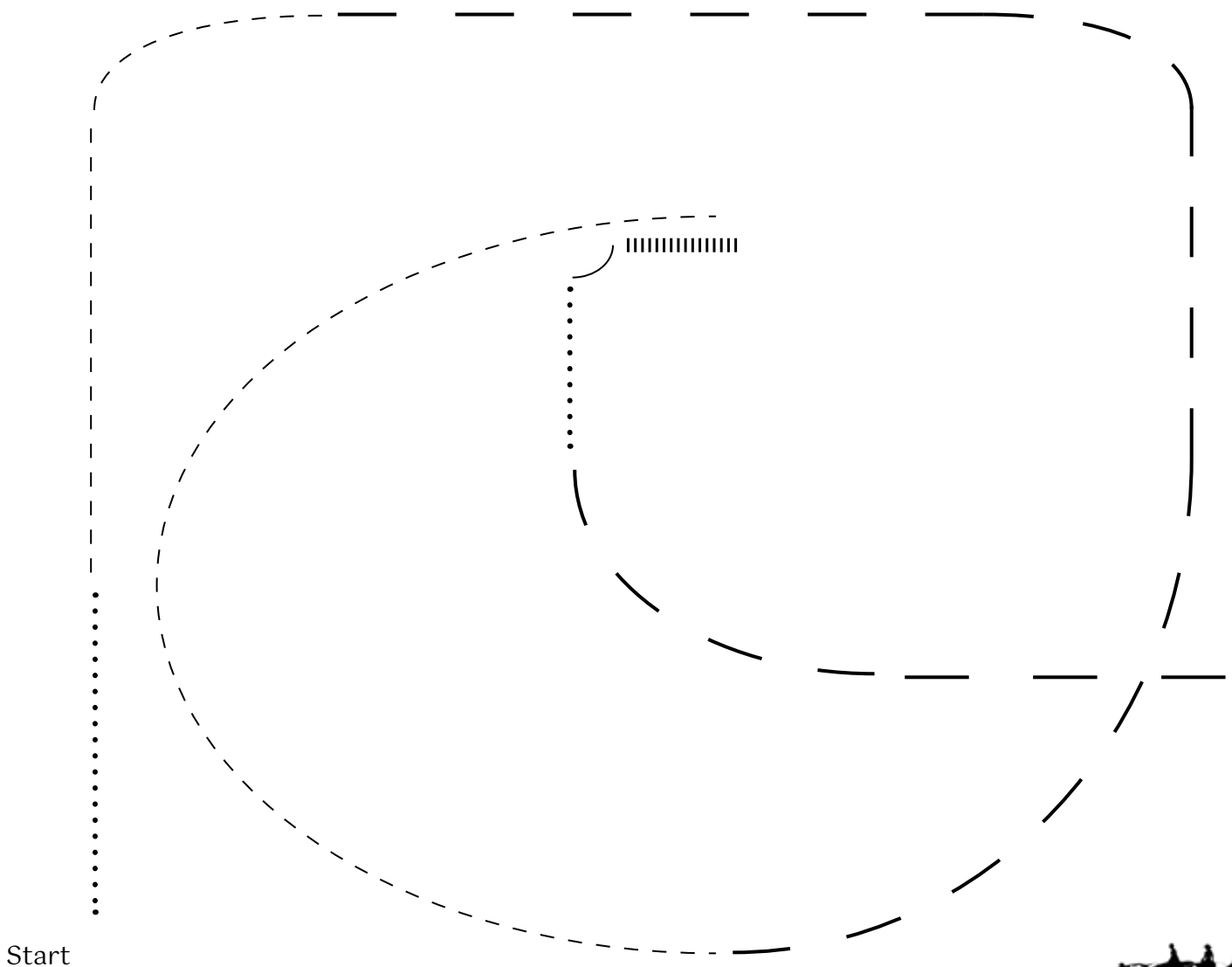

Walk •••••

Sitting Trot - - - -

Trot — — —

Back |||||



# English Equitation

## Classes

## Instructions

- 118 - AM Jr Walk/Trot - Hunt Seat Equitation, Solid
- 119 - AM Sr/El Walk/Trot - Hunt Seat Equitation, Solid
- 120 - YA Walk/Trot, 11 - 18 yo - Hunt Seat Equitation, Horse/Pony
- 121 - YA Walk/Trot, 11 - 18 yo - Hunt Seat Eq, Solid Horse/Pony
- 179 - AM Jr Walk/Trot - Hunt Seat Equitation
- 180 - AM Sr Walk/Trot - Hunt Seat Equitation
- 181 - AM El Walk/Trot - Hunt Seat Equitation

1. Walk
2. Sitting trot
3. Trot
4. Sitting trot, stop
5. Execute ¼ turn right on the forehand
6. Trot, stop
7. Back one horse length
8. Walk to exit

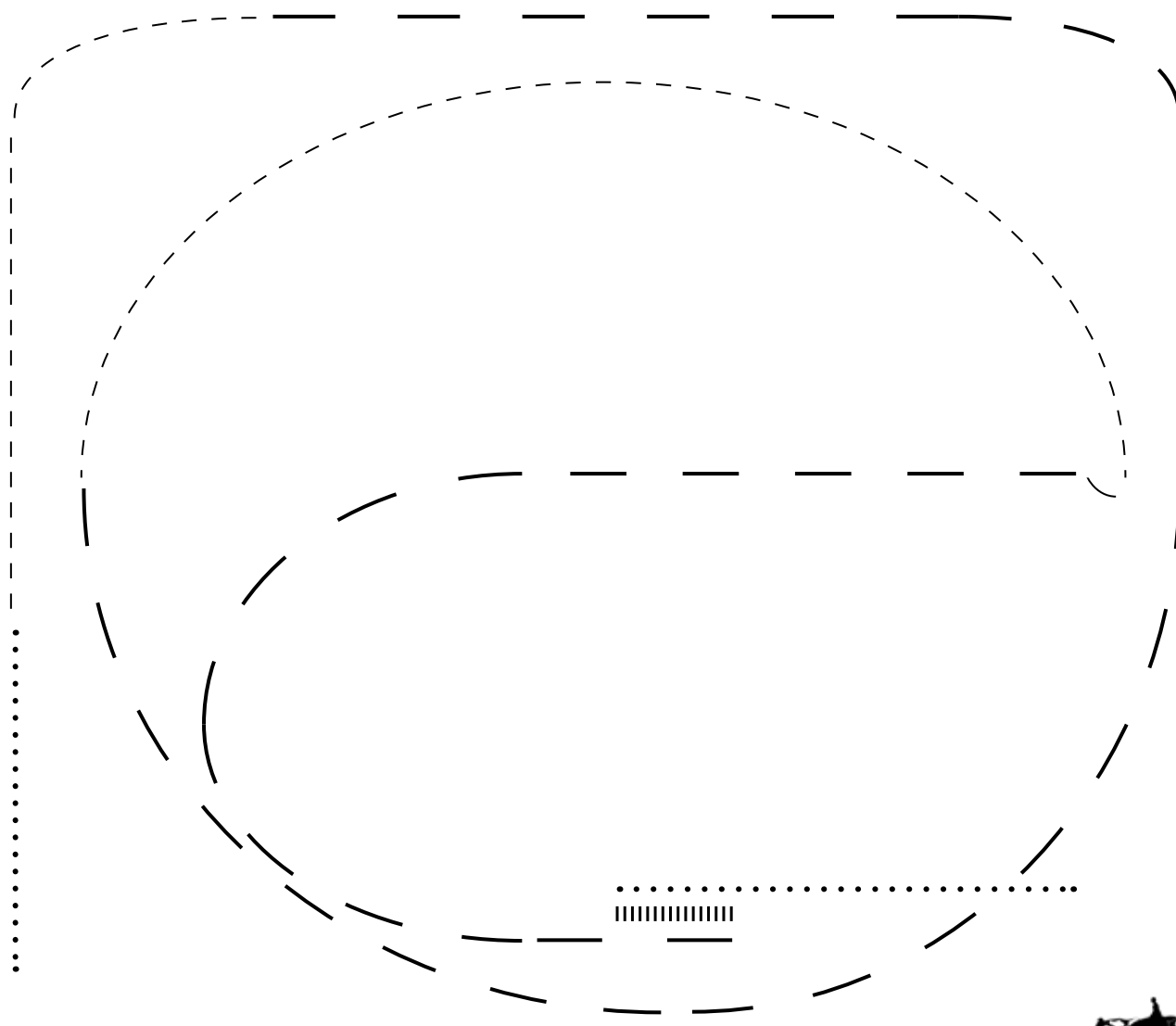

Start

Walk .....

Sitting Trot - - - -

Trot — —

Back |||||



# English Equitation

## Classes

125 - YA Novice - Hunt Seat Equitation, Solid Horse/Pony  
 173 - YA Jr Novice - Hunt Seat Equitation, Horse/Pony  
 177 - AM Novice - Hunt Seat Equitation  
 178 - AM Novice - Hunt Seat Equitation, Solid

## Instructions

1. Walk
2. Sitting trot
3. Canter, right lead
4. Trot, stop
5. Execute  $\frac{1}{4}$  turn right on the forehand
6. Canter, left lead, stop
7. Back one horse length
8. Sitting trot
9. Trot to exit

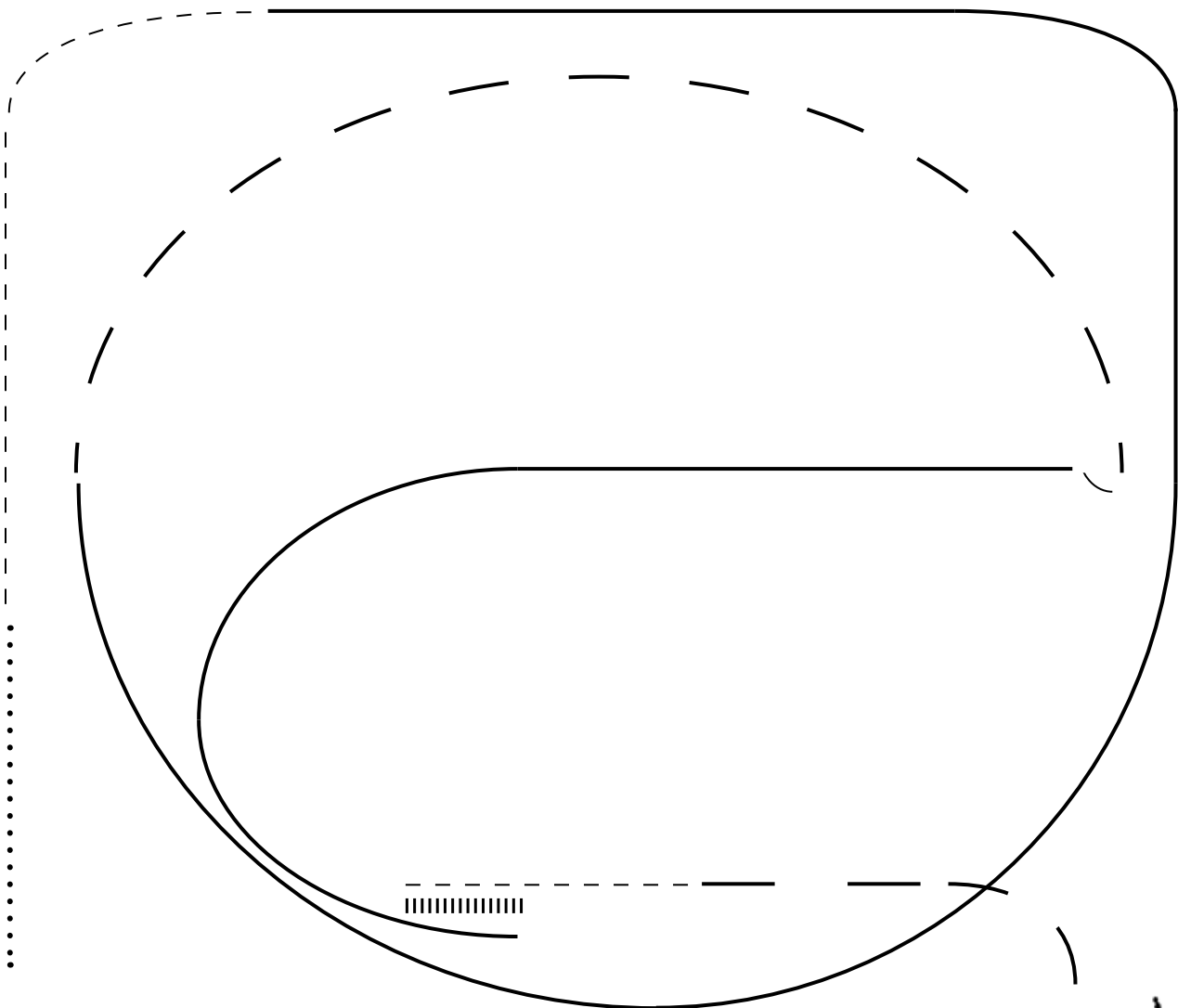

Start

Walk .....  
 Canter ———

Sitting Trot - - - -

Trot — — —

Back |||||



# English Equitation

Classes	Instructions
114 - YA Jr - Hunt Seat Equitation, Horse/Pony (NSBA) 116 - YA Jr - Hunt Seat Equitation, Solid Horse/Pony (NSBA) 172 - YA Sr Novice - Hunt Seat Equitation, Horse/Pony 175 - AM Sr - Hunt Seat Equitation (NSBA) 176 - AM Elite - Hunt Seat Equitation (NSBA) 183 - AM Sr/El - Hunt Seat Equitation, Solid (NSBA)	1. Sitting trot 2. Trot 3. Walk 4. Canter, right lead, stop 5. Execute ½ turn right on the forehand 6. Back one horse length 7. Walk 8. Trot 9. Canter, left lead 10. Sitting trot to exit

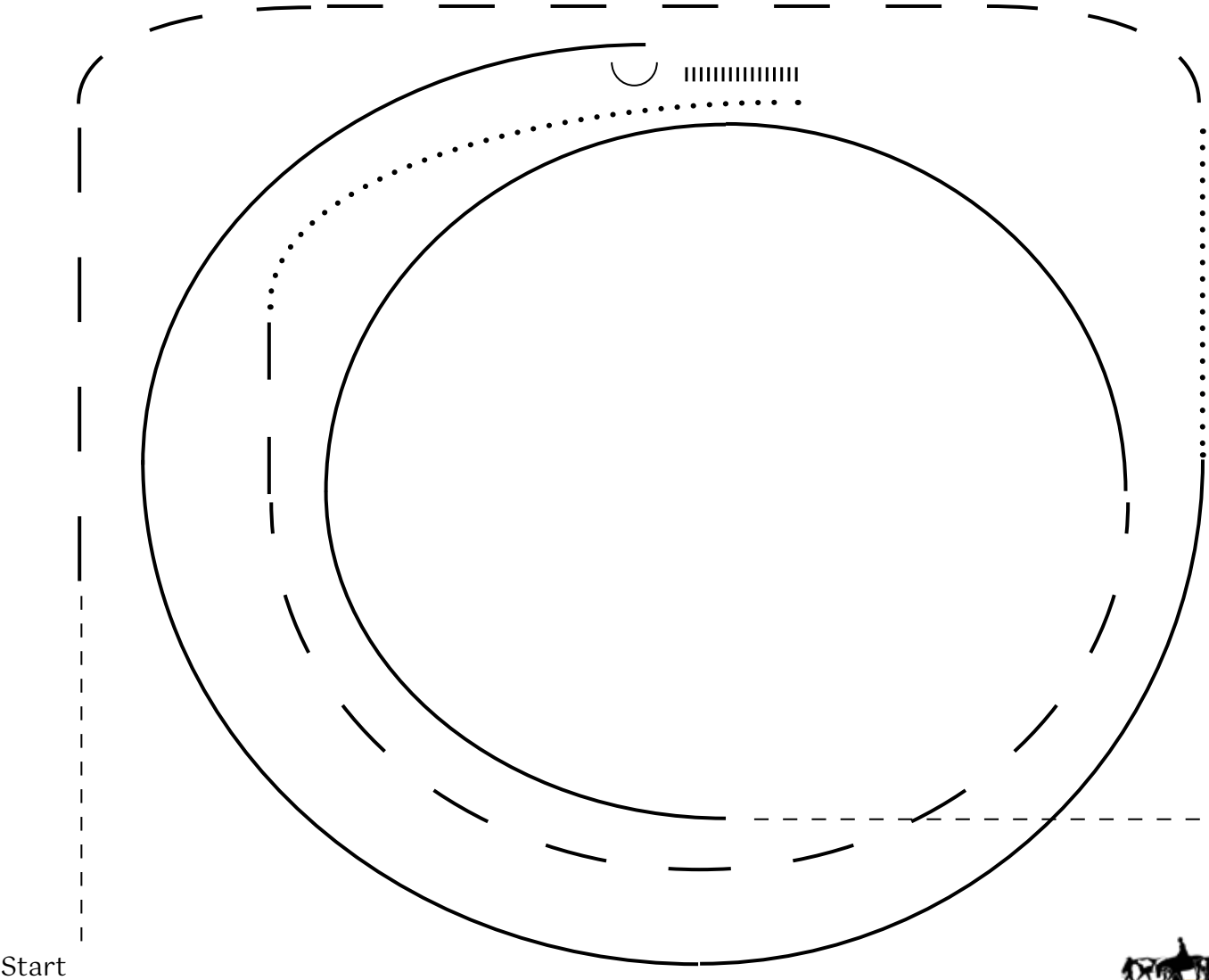

Start

Walk .....      Sitting Trot - - - -      Trot — — — —  
 Canter ————      Back |||||



# English Equitation

## Classes

- 115 - YA Sr - Hunt Seat Equitation, Horse/Pony (NSBA)
- 117 - YA Sr - Hunt Seat Equitation, Solid Horse/Pony (NSBA)
- 174 - AM Jr - Hunt Seat Equitation (NSBA)
- 182 - AM Jr - Hunt Seat Equitation, Solid (NSBA)

## Instructions

1. Canter, left lead
2. Walk
3. Trot
4. Canter, right lead
5. Hand gallop
6. Canter
7. Trot, stop
8. Back one horse length
9. Execute ½ turn right on the forehand
10. Sitting trot to exit

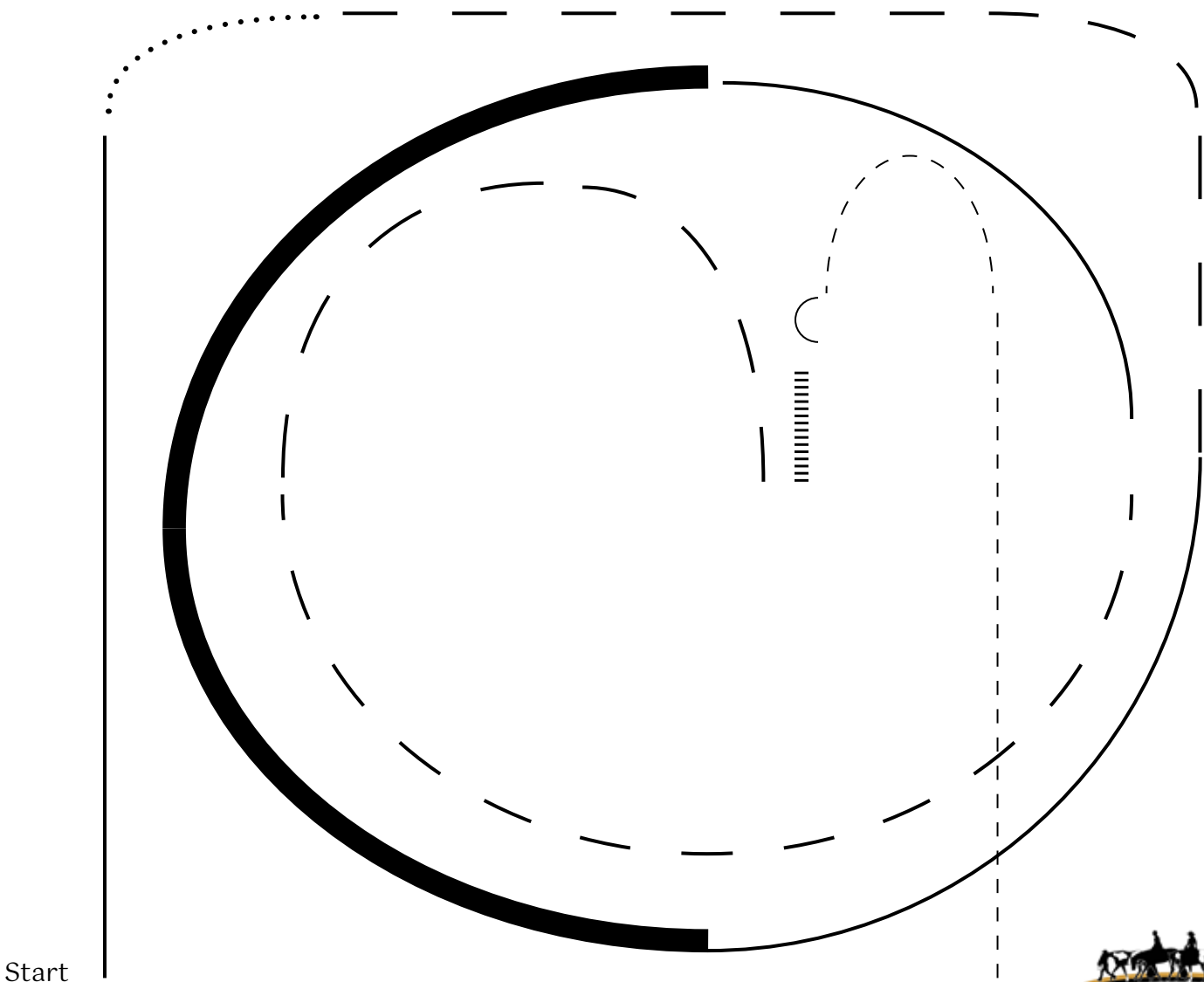

Start

- |            |                          |            |
|------------|--------------------------|------------|
| Walk ••••• | Sitting Trot - - - -     | Trot — — — |
| Canter ——— | Hand Gallop <b>—————</b> | Back       |



# Bareback English Equitation

## Classes

71 - YA Jr - Bareback Hunt Seat Equitation, Horse/Pony  
 72 - YA Sr - Bareback Hunt Seat Equitation, Horse/Pony  
 73 - YA - Bareback Hunt Seat Equitation, Solid Horse/Pony  
 236 - AM - Bareback Hunt Seat Equitation  
 237 - AM - Bareback Hunt Seat Equitation, Solid

## Instructions

1. Execute ¼ turn left on the forehand
2. Sitting trot
3. Stop, back one horse length
4. Walk
5. Canter, left lead
6. Trot
7. Canter, right lead
8. Sitting trot to exit

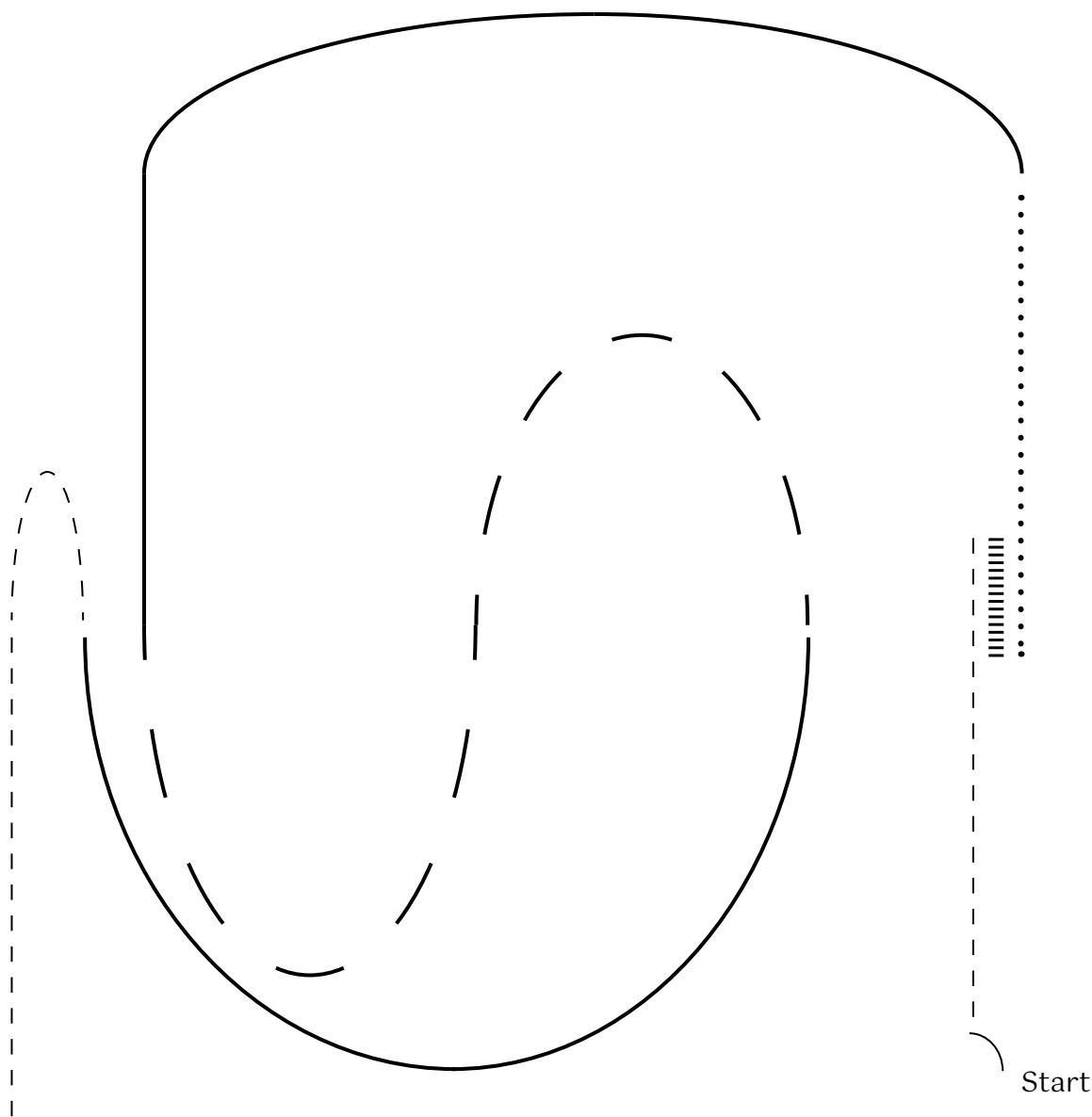

Walk •••••

Sitting Trot - - - -

Trot — — —

Canter —————

Back |||||



# Bareback Western Horsemanship

## Classes

- 582 - YA - Bareback Western Horsemanship, Solid Horse/Pony
- 583 - YA Jr - Bareback Western Horsemanship, Horse/Pony
- 584 - YA Sr - Bareback Western Horsemanship, Horse/Pony
- 618 - AM Bareback Western Horsemanship
- 633 - AM Bareback Western Horsemanship, Solid

## Instructions

1. Back one horse length
2. Execute 1/2 turn right on the haunches
3. Jog
4. Extended jog
5. Stop, hesitate briefly
6. Lope, left lead
7. Walk
8. Lope, right lead
9. Jog to exit

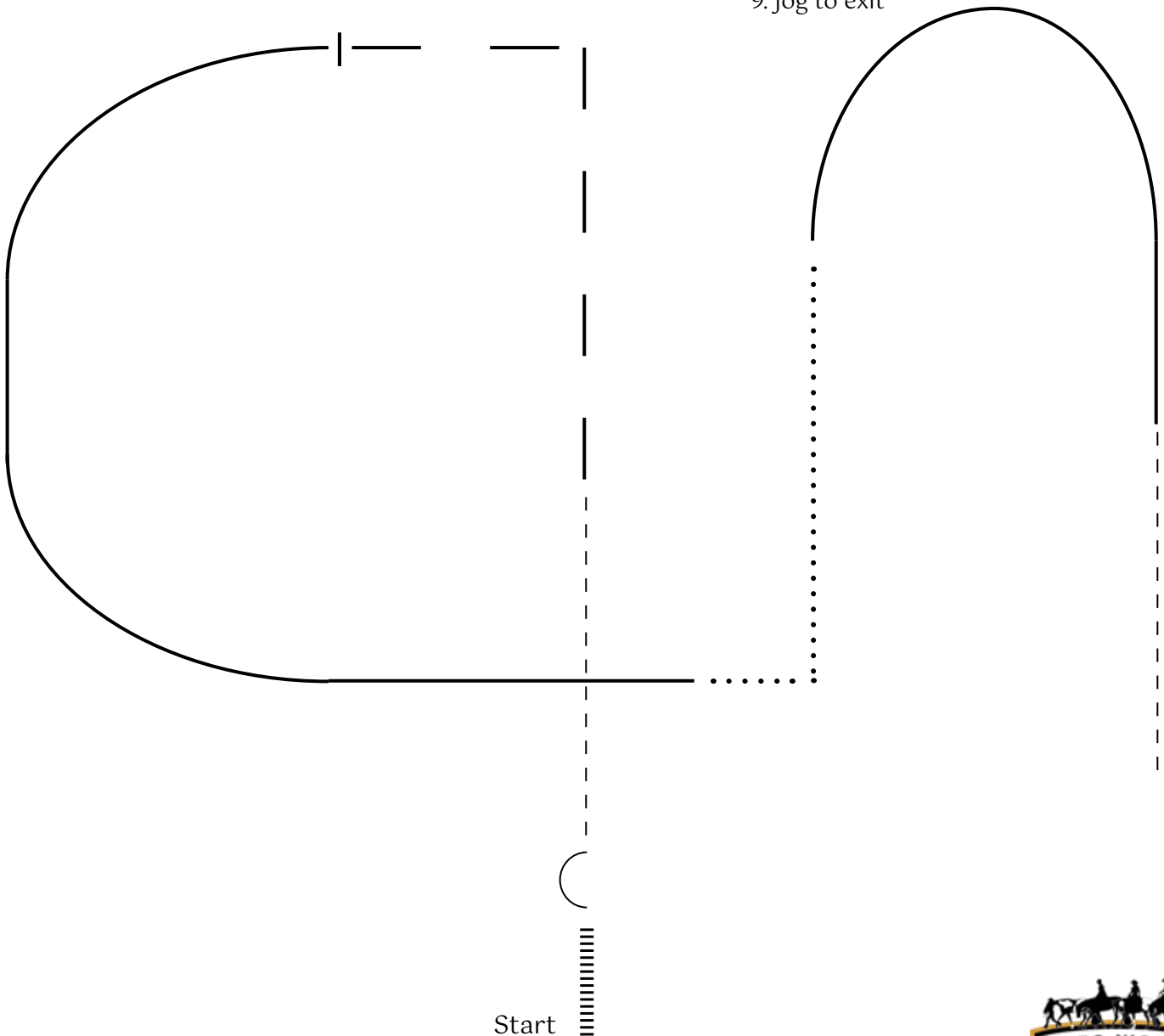

Walk ..... Jog - - - - Extended Jog — — — —  
 Lope ————— Back |||||



# Western Horsemanship

## Classes

542 - YA W/T, 10 & u - Western Horsemanship, Horse/Pony  
 543- YA W/T, 10 & u - Western Horsemanship, Solid Hrse/Pny  
 544- YA Leadline W/T, 8 & u - Western Horsemanship  
 545 - YA Leadline W/T, 8 & u - Western Horsemanship, Solid

## Instructions

1. Jog
2. Walk
3. Jog
4. Extended jog
5. Walk, stop
6. Execute 1 turn left on the haunches
7. Back one horse length
8. Walk to exit

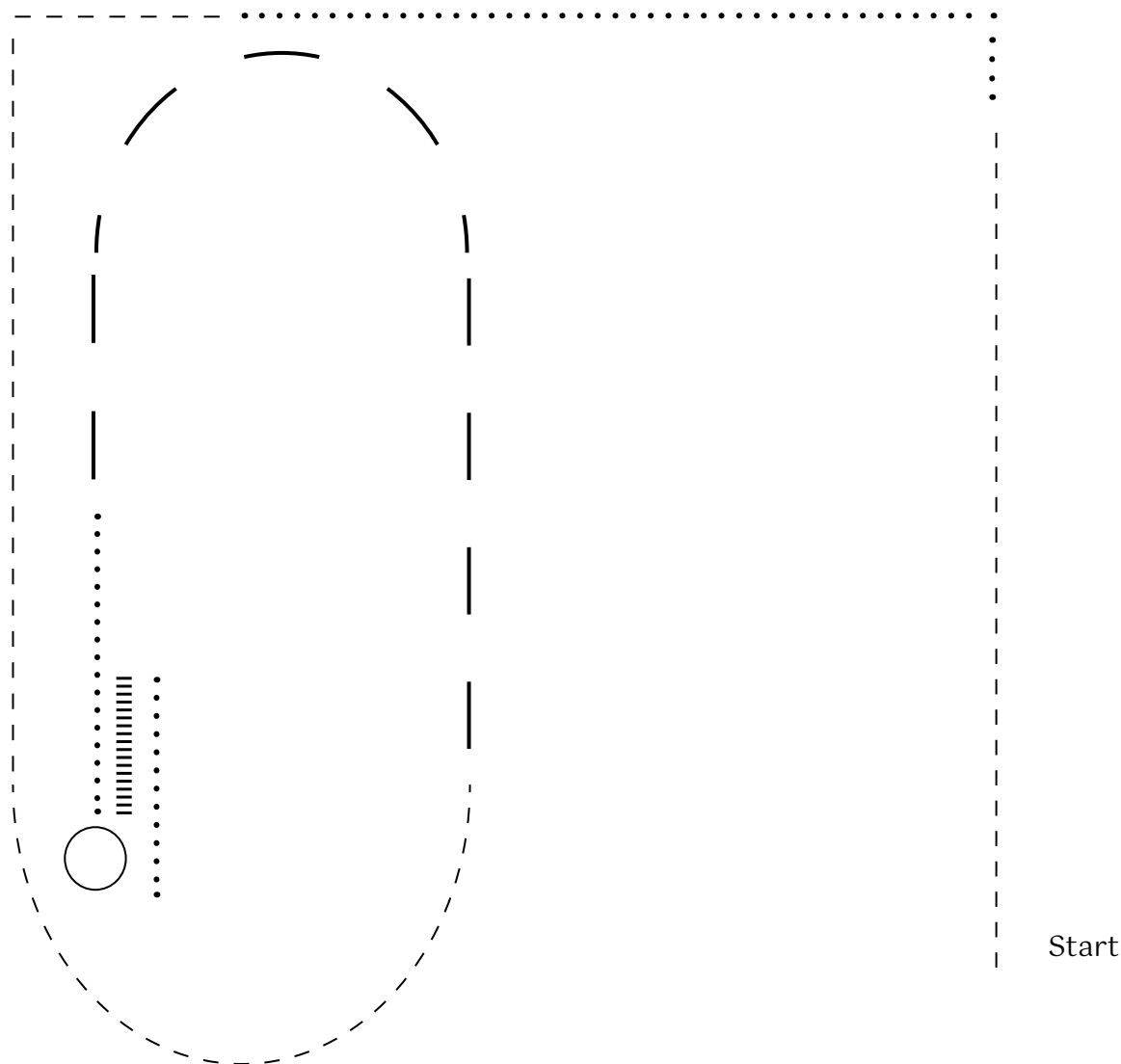

Walk ..... Jog - - - -

Extended Jog — — — —  
 Back |||||





# Western Horsemanship

## Classes

## Instructions

594 - YA Novice - Western Horsemanship, Solid Hrse/Pny  
 597 - YA Jr Novice - Western Horsemanship, Horse/Pony  
 629 - AM Novice - Western Horsemanship  
 643 - AM Novice - Western Horsemanship, Solid

1. Jog
2. Lope, right lead
3. Walk
4. Jog
5. Extended jog
6. Lope, left lead
7. Jog, stop
8. Execute 1 turn left on the haunches
9. Back one horse length
10. Walk to exit

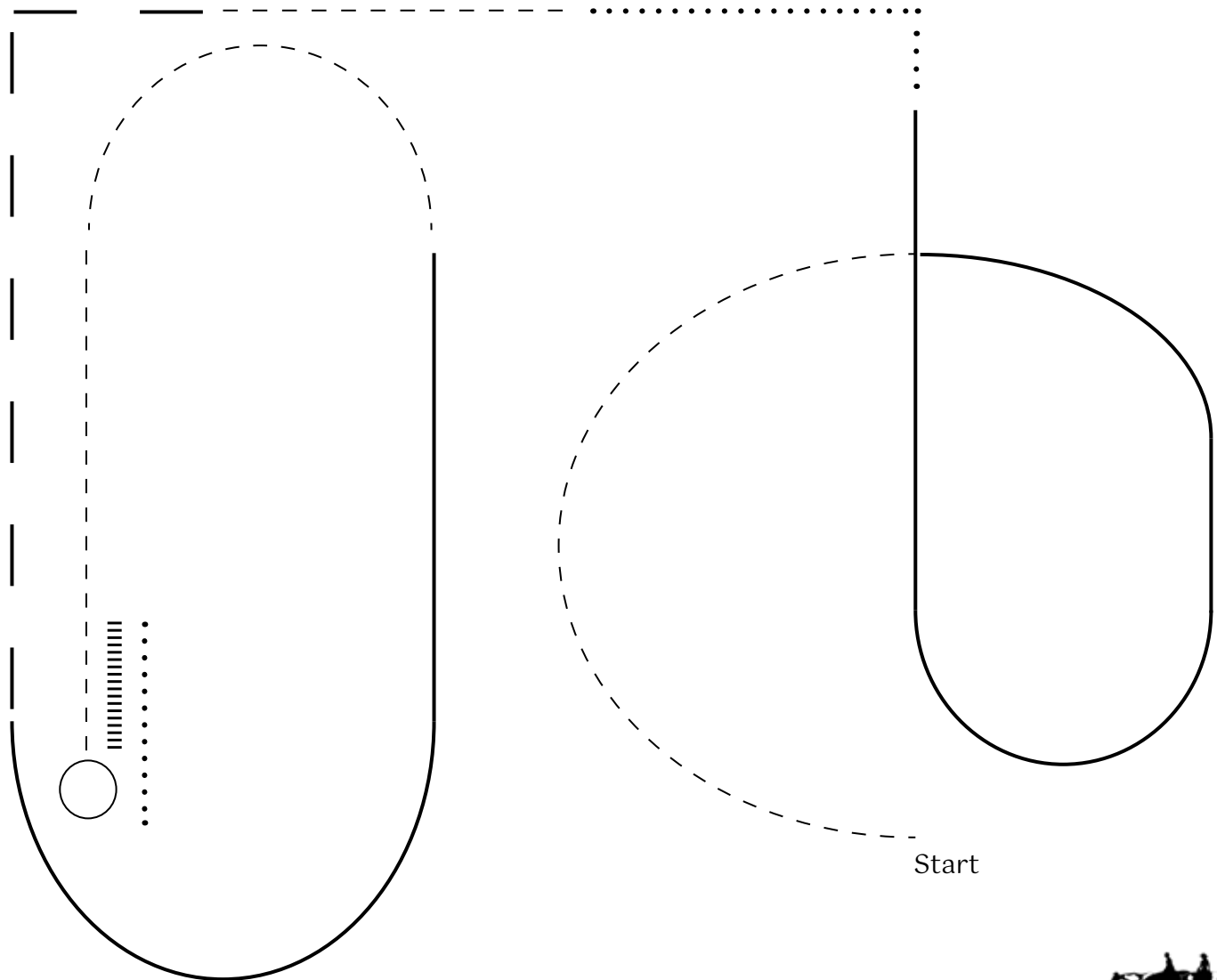

Walk .....

Jog - - - -

Extended Jog — —

Lope ———

Back |||||



# Western Horsemanship

## Classes

## Instructions

- 592 - YA Jr - Western Horsemanship, Solid Horse/Pony (NSBA)
- 595 - YA Jr - Western Horsemanship, Horse/Pony (NSBA)
- 598 - YA Sr Novice - Western Horsemanship, Horse/Pony
- 627 - AM Sr - Western Horsemanship (NSBA)
- 628 - AM Elite - Western Horsemanship (NSBA)
- 640 - AM Sr/El - Western Horsemanship, Solid (NSBA)

1. Execute  $\frac{3}{4}$  turn right on the haunches
2. Jog
3. Lope, right lead
4. Jog
5. Extended jog
6. Jog
7. Lope, left lead
8. Walk, jog, stop
9. Execute 1 turn left on the haunches
10. Back two horse lengths, walk to exit

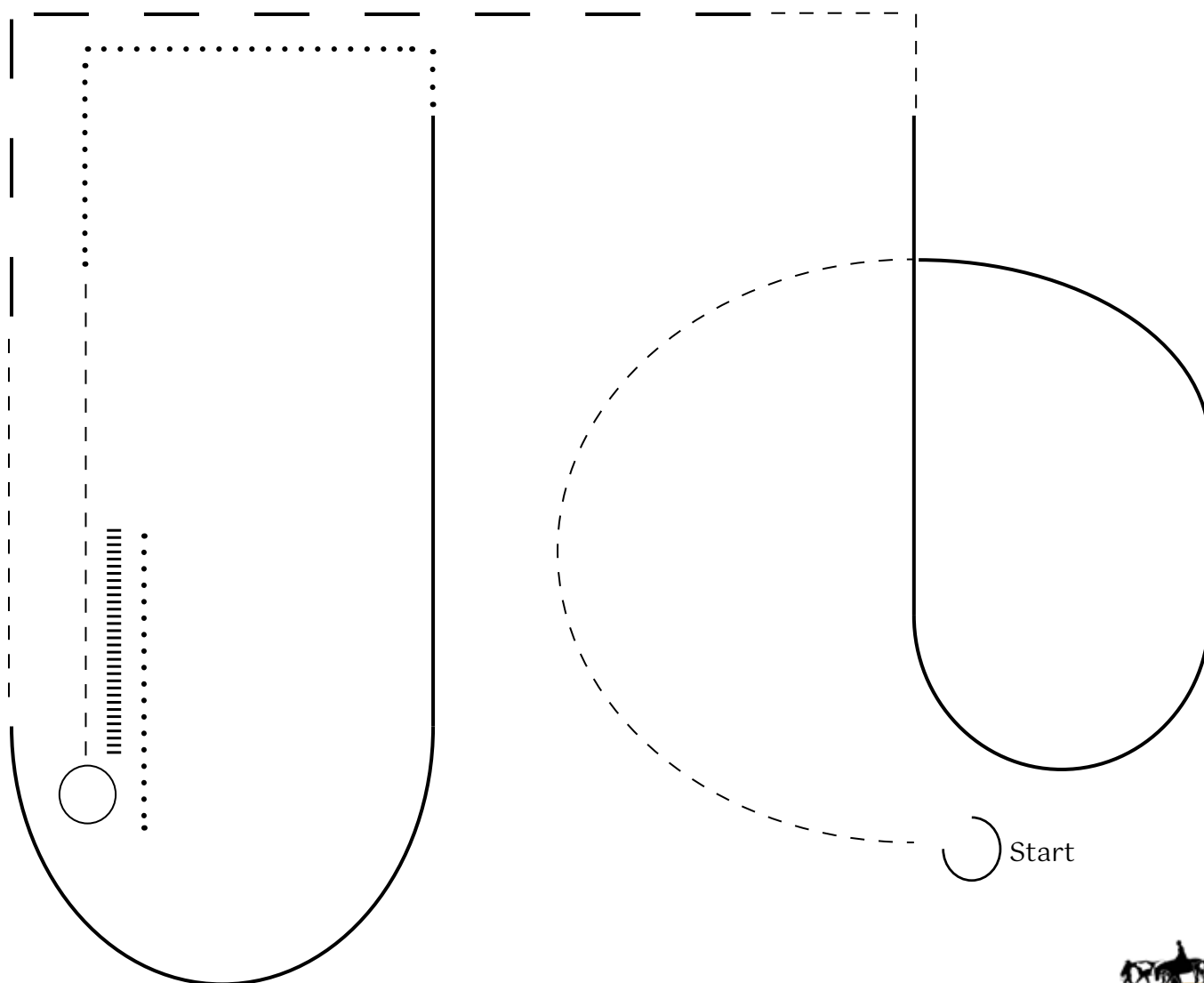

Walk .....  
Lope ———

Jog - - - -

Extended Jog — — —

Back |||||



# Western Horsemanship

## Classes

## Instructions

- 593 - YA Sr - Western Horsemanship, Solid Horse/Pony (NSBA)
- 596 - YA Sr - Western Horsemanship, Horse/Pony (NSBA)
- 626 - AM Jr - Western Horsemanship (NSBA)
- 639 - AM Jr - Western Horsemanship, Solid (NSBA)

1. Execute  $\frac{3}{4}$  turn right on the haunches
2. Lope, right lead
3. Jog, extended jog, jog
4. Lope, left lead, change leads (simple or flying)
5. Walk
6. Jog, stop
7. Execute  $1\frac{1}{4}$  turn left on the haunches
8. Jog, stop
9. Back two horse lengths
10. Walk to exit

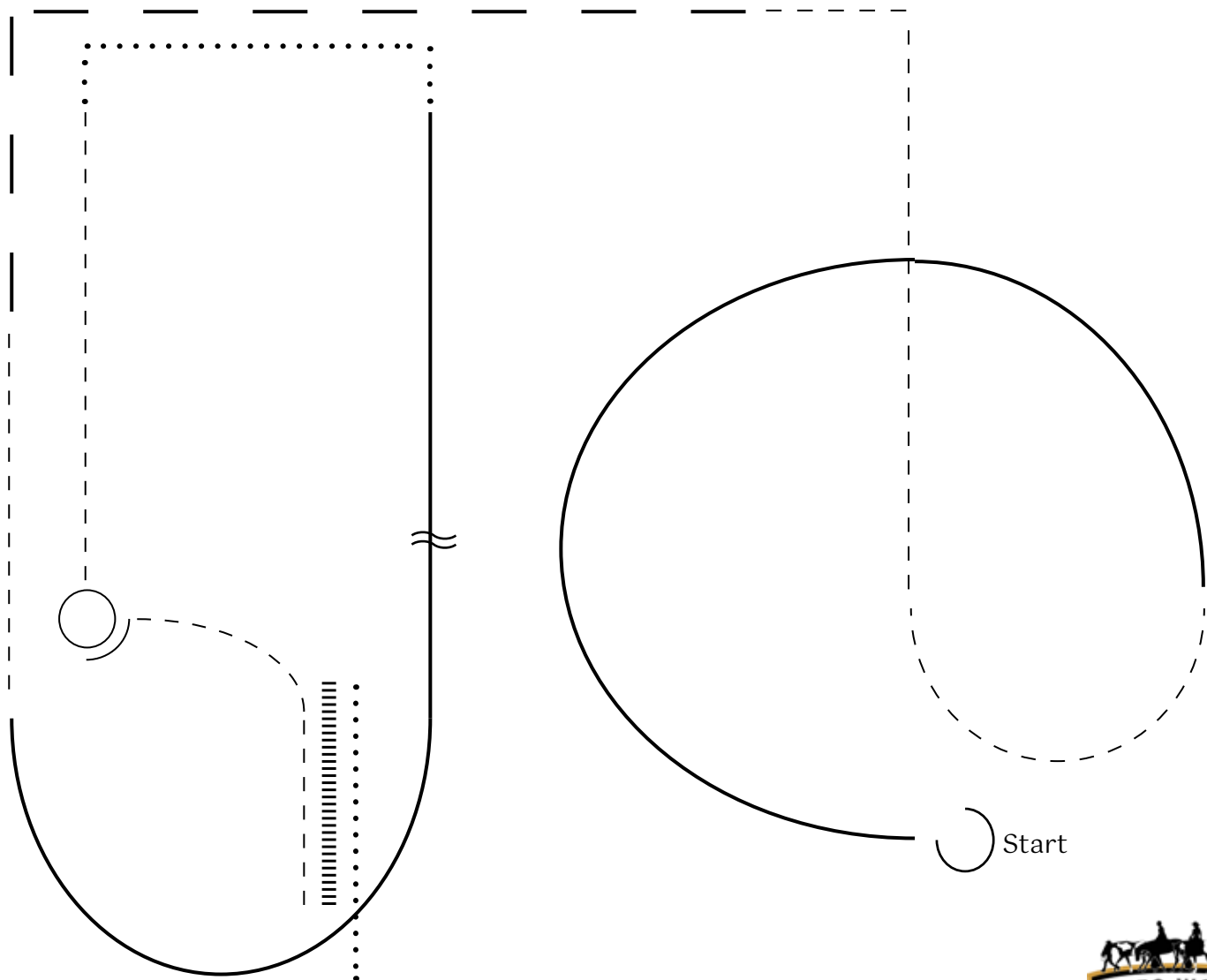

Walk •••••

Jog - - - -

Extended Jog — — —

Lope —————

Lead Change ≈

Back |||||



# Ranch Horsemanship

## Classes

## Instructions

- 110 - YA Walk/Trot 10 & u - Ranch Horsemanship, Solid Hrse/Pny
- 111 - YA Walk/Trot 10 & u - Ranch Horsemanship Horse/Pony
- 112 - YA Walk/Trot 11 - 18 - Ranch Horsemanship, Solid Hrse/Pny
- 113 -YA Walk/Trot 11 - 18 - Ranch Horsemanship Horse/Pony
- 260 - AM Walk/Trot- Ranch Horsemanship
- 263 - AM Walk/Trot- Ranch Horsemanship, Solid

1. Execute 1 turn right on the haunches
2. Trot
3. Extended trot
4. Trot
5. Stop
6. Back one horse length
7. Walk to exit

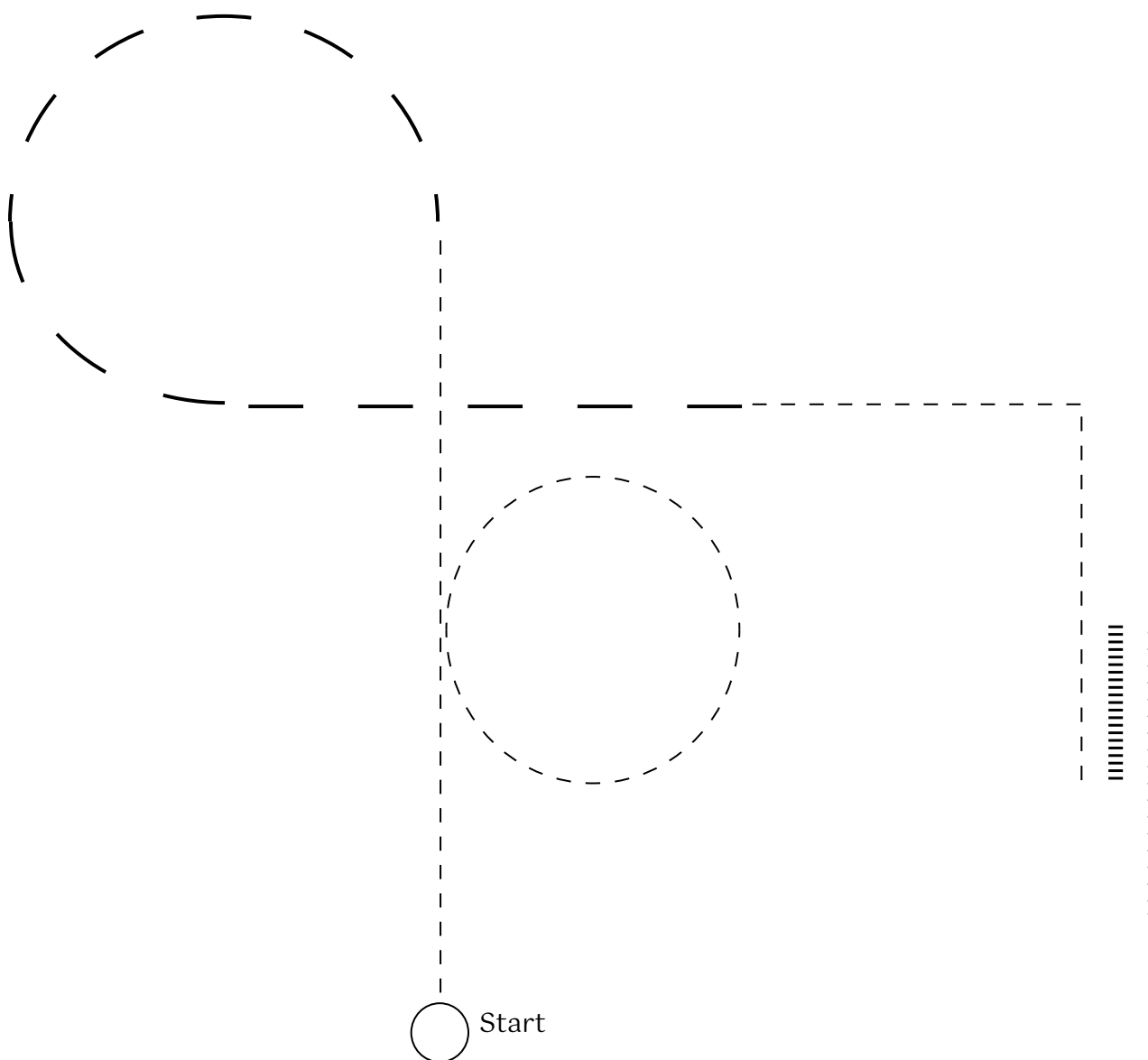

Walk •••••

Trot - - - -

Extended Trot — —

Back |||||





# Ranch Horsemanship

## Classes

109 - YA Sr - Ranch Horsemanship, Solid Horse/Pony  
 259 -AM - Ranch Horsemanship  
 261 - AM Jr - Ranch Horsemanship, Solid

## Instructions

1. Execute 1 turn right on the haunches
2. Lope, right lead
3. Trot
4. Lope, left lead
5. Trot
6. Extended trot
7. Stop
8. Back two horse lengths
9. Walk to exit

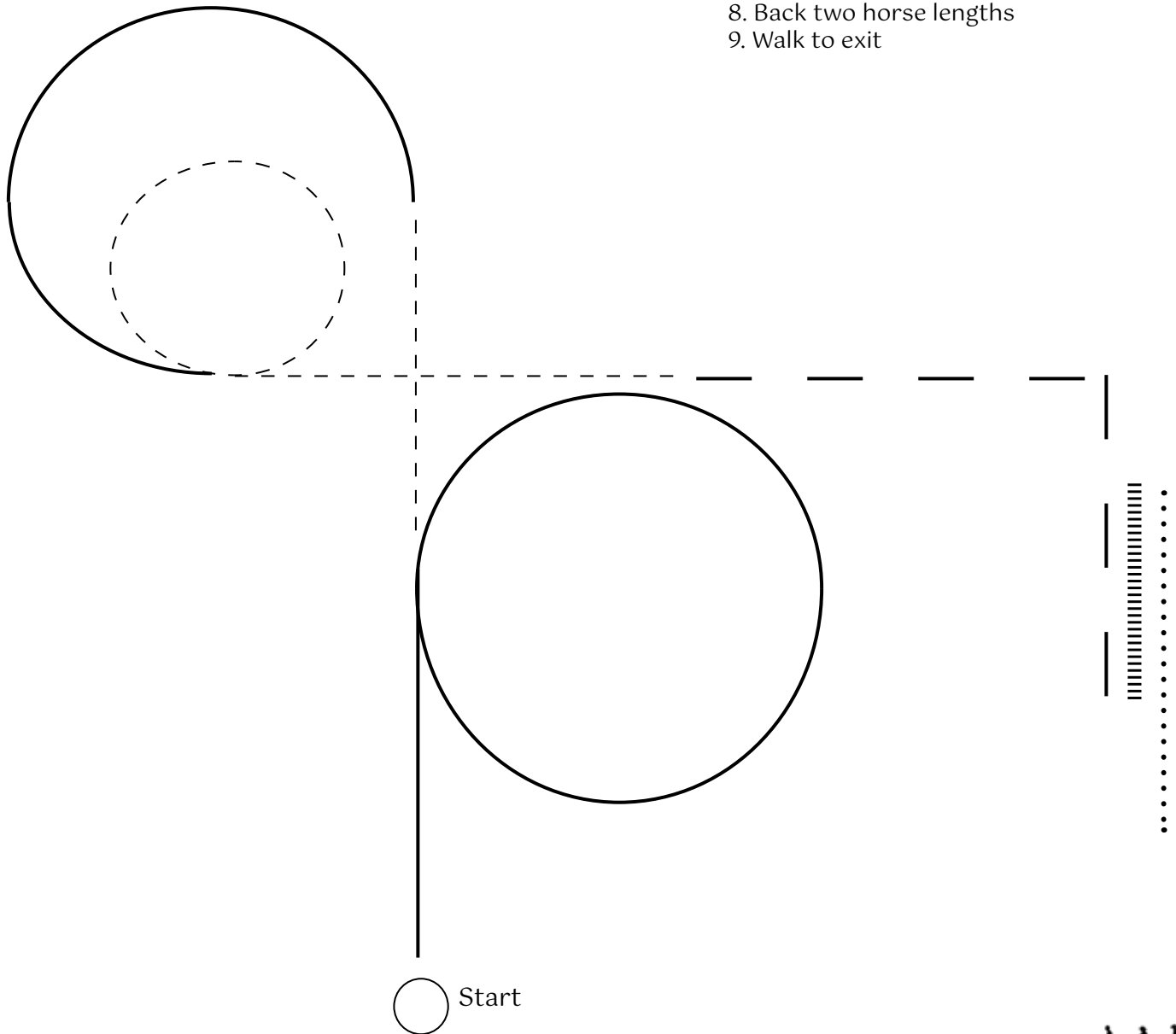

Walk .....  
 Lope ———

Trot - - - -

Extended Trot — —

Back |||||



# Reinsmanship

## Classes

## Instructions

- 257 - AM - Reinsmanship Driving Equitation, Horse
- 258 - YA - Reinsmanship Driving Equitation, Horse
- 767 - YA - Reinsmanship Driving Equitation, Mini/B Mini/Pony
- 768 - AM - Reinsmanship Driving Equitation, Mini/B Mini/Pony

1. Rein back, 5 steps
2. Working trot
3. Strong trot
4. Working trot
5. Walk
6. Slow trot
7. Working trot
8. Walk to exit

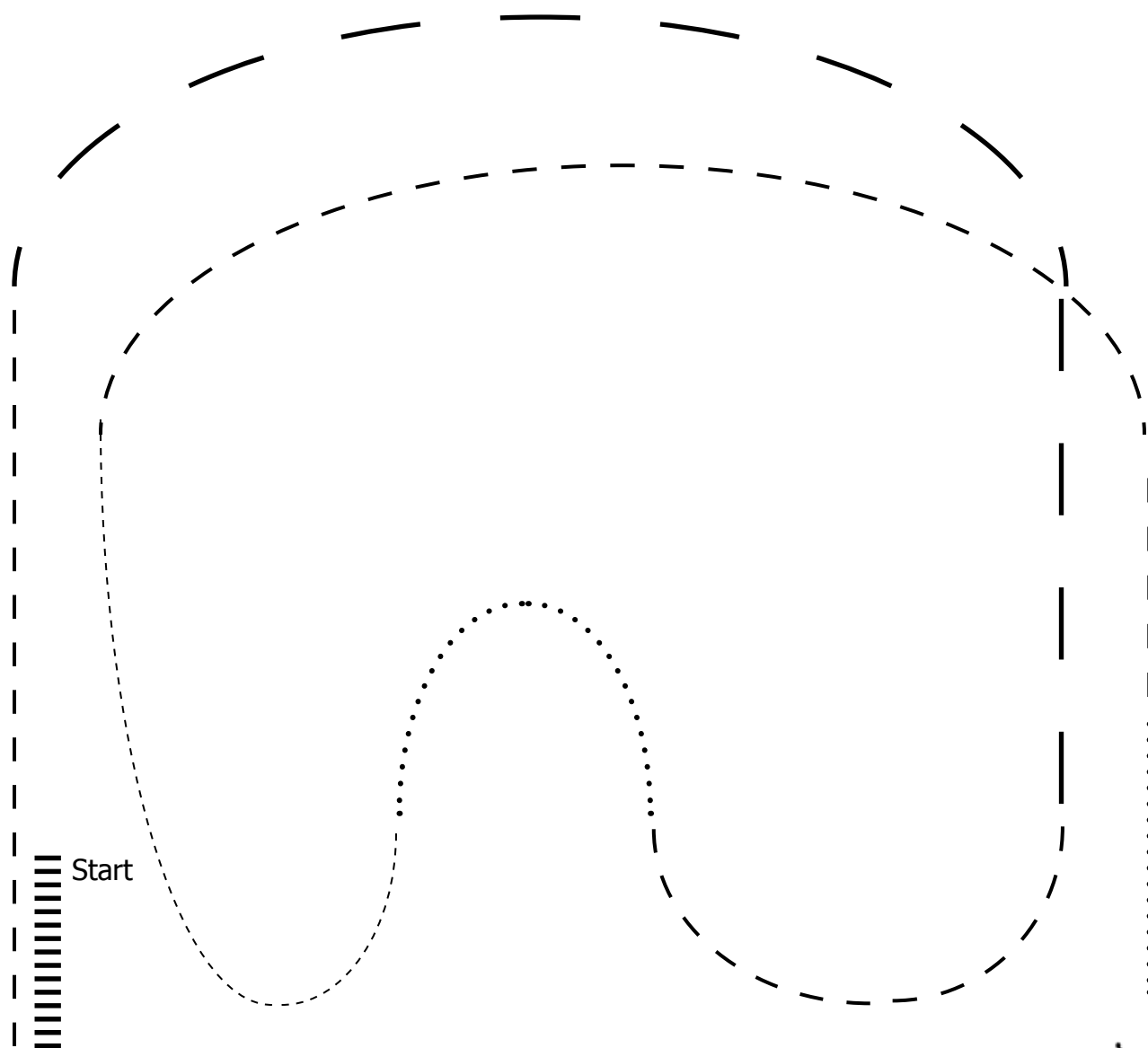

Walk .....

Slot Trot - - - - -

Working Trot - - -

Strong Trot — — —

Lope —————

Back |||||



# Obstacle Driving

## Classes

- 664 - OP - Obstacle Driving, Miniature
- 665 - OP - Obstacle Driving, B Mini
- 666 - OP - Obstacle Driving, Solid Miniature/B Mini
- 667 - YA - Obstacle Driving, Miniature/B Miniature/Pony
- 668 - AM - Obstacle Driving, Miniature/B Miniature
- 669 - AM - Obstacle Driving, Pony
- 670 - OP - Obstacle Driving, Pony
- 671 - OP - Obstacle Driving, Solid Pony

## Instructions

1. Walk over plywood on the ground
2. Walk up to and pick up object, then trot around center marker, stop, drop off object in original location
3. Walk, stop, back into chute, walk out
4. Walk up to poles, keep left wheel between poles while walking forward
5. Trot between poles
6. Trot serpentine
7. Walk through "U"

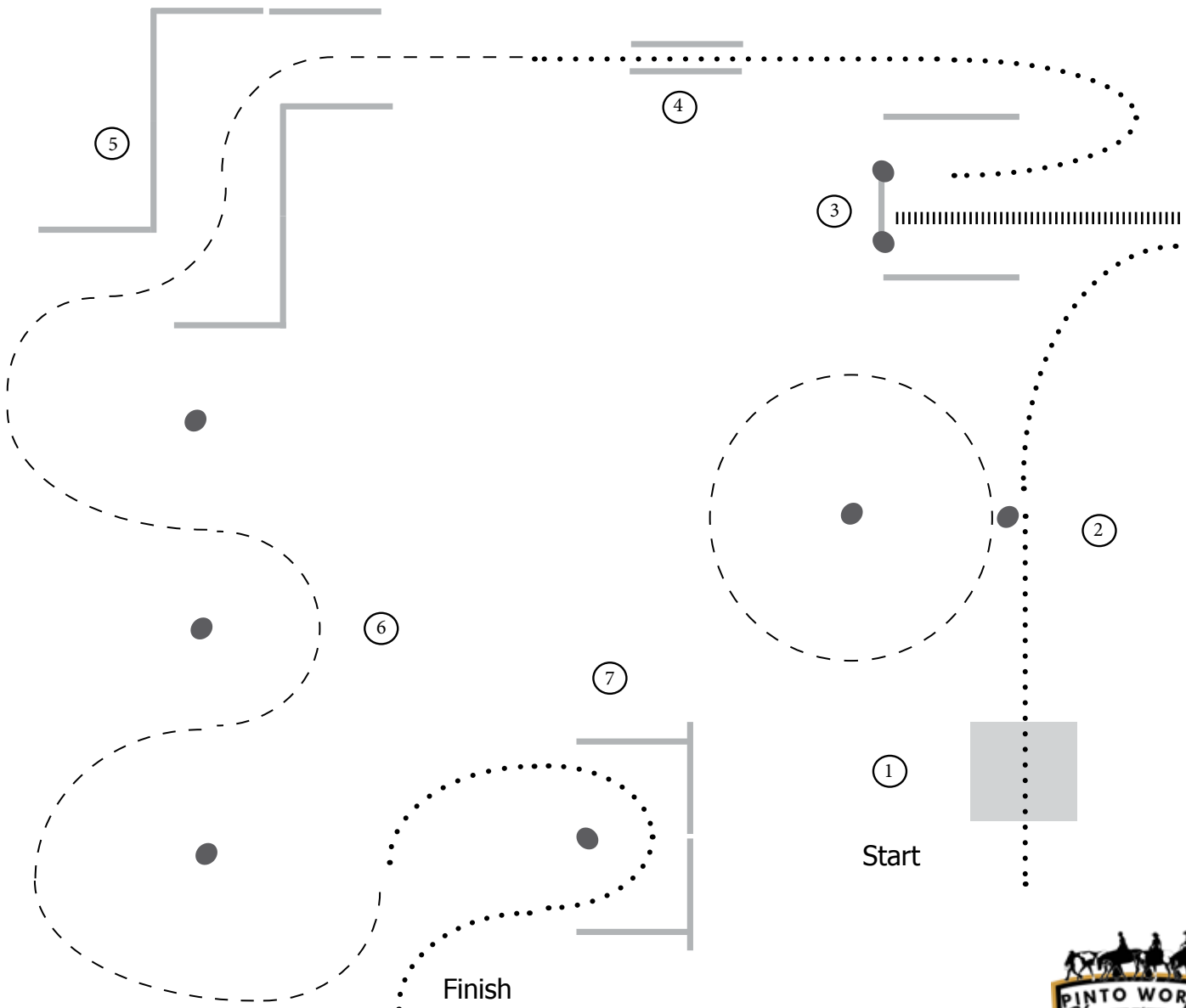

# Western Riding

---

---

## Classes

## Instructions

---

564 - OP - Western Riding, Solid (NSBA)  
565 - OP - Western Riding (NSBA)

### WESTERN RIDING PATTERN #1

1. Walk, jog over log
2. Transition to left lead and lope around end
3. First line change
4. Second line change
5. Third line change
6. Fourth line change and lope around the end of arena
7. First crossing change
8. Second crossing change
9. Lope over log
10. Third crossing change
11. Fourth crossing change
12. Lope up the center, stop and back

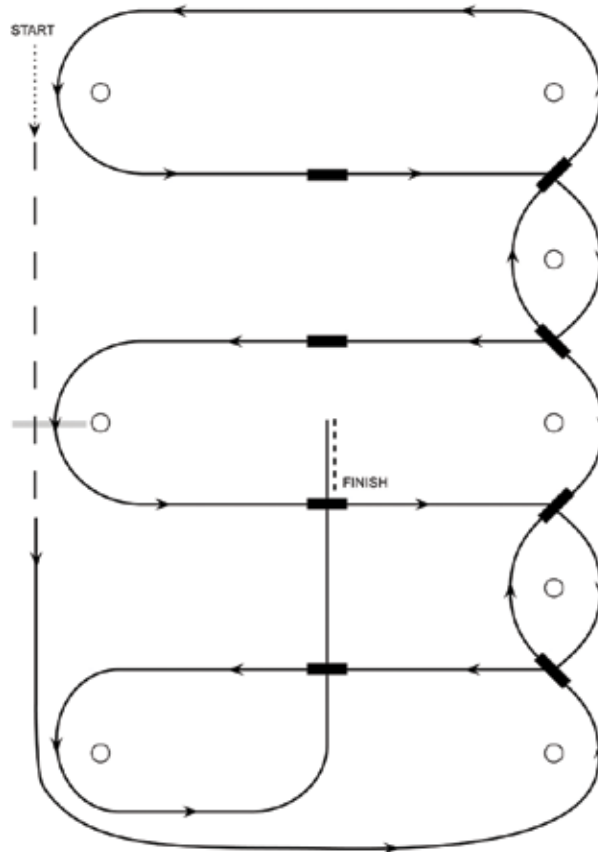

# Western Riding

## Classes

370 - YA - Western Riding, Horse/Pony (NSBA)  
371 - YA - Western Riding, Solid Horse/Pony (NSBA)  
566 - AM - Western Riding, Solid (NSBA)  
567 - AM - Western Riding (NSBA)

## Instructions

- WESTERN RIDING PATTERN #3
1. Walk, transition to jog, jog over log
  2. Transition to left lead lope
  3. First crossing change
  4. Lope over log.
  5. Second crossing change
  6. First line change
  7. Second line change
  8. Third line change
  9. Fourth line change
  10. Third crossing change
  11. Fourth crossing change
  12. Lope up the center, stop & back

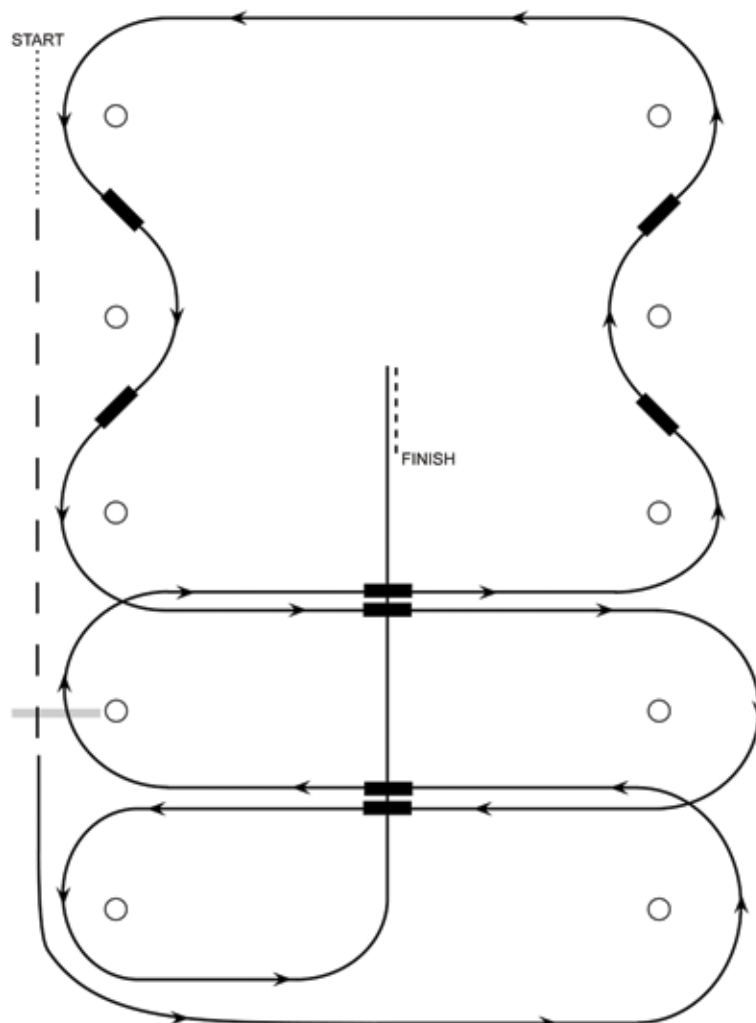

# Western Riding

## Classes

562 - OP - Green Western Riding  
563 - OP - Green Western Riding, Solid

## Instructions

### GREEN WESTERN RIDING PATTERN #1

1. Walk at least 15' and jog over log
2. Transition to left lead and lope around end
3. First line change
4. Second line change
5. First crossing change
6. Second crossing change
7. Lope over log
8. Third crossing change
9. Fourth crossing change
10. Lope up the center, stop and back

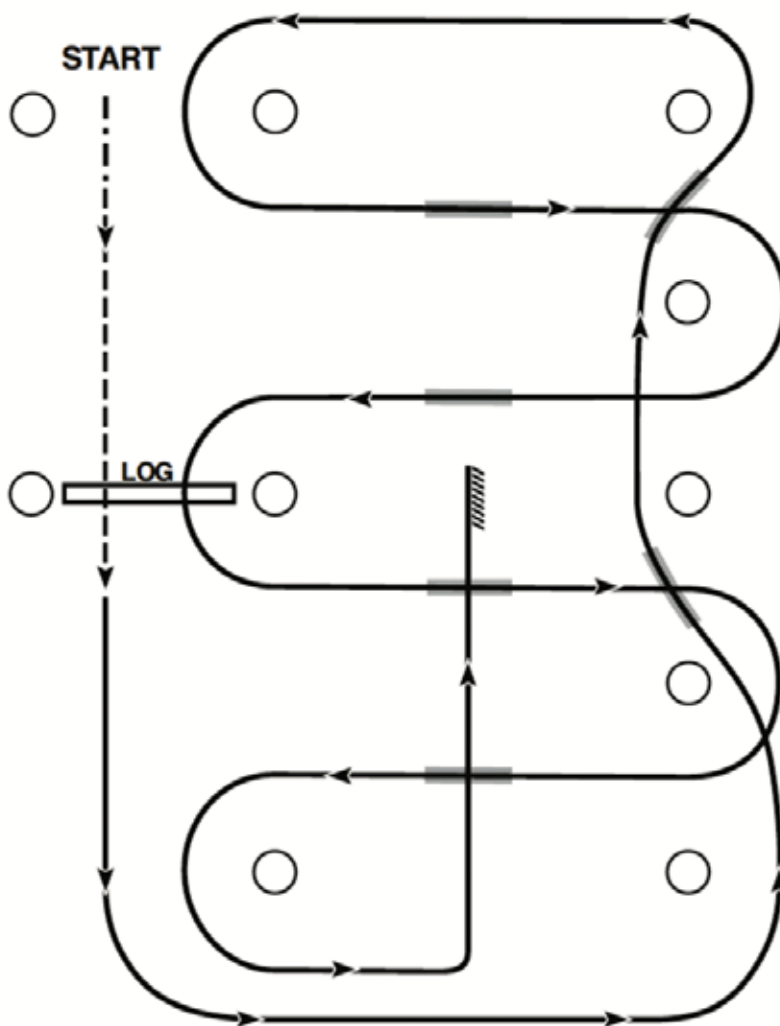

# Ranch Riding

## Classes

- 221 - YA Walk/Trot 10 & u - Ranch Riding Horse/Pony
- 222 - YA Walk/Trot 11 - 18 - Ranch Riding Horse/Pony
- 223 - AM Walk/Trot- Ranch Riding
- 224 - YA Walk/Trot 11 - 18 - Ranch Riding, Solid Horse/Pony
- 225 - YA Walk/Trot 10 & u - Ranch Riding, Solid Horse/Pony
- 226 - AM Walk/Trot- Ranch Riding, Solid

## Instructions

### RANCH RIDING -- PATTERN #7

1. Walk
2. Trot
3. Extended trot
4. Stop and back
5. Side pass over log right
6. ¼ turn right, walk over logs
7. Walk
8. Extended trot
9. Trot
10. Stop, one 360 degree turn either direction

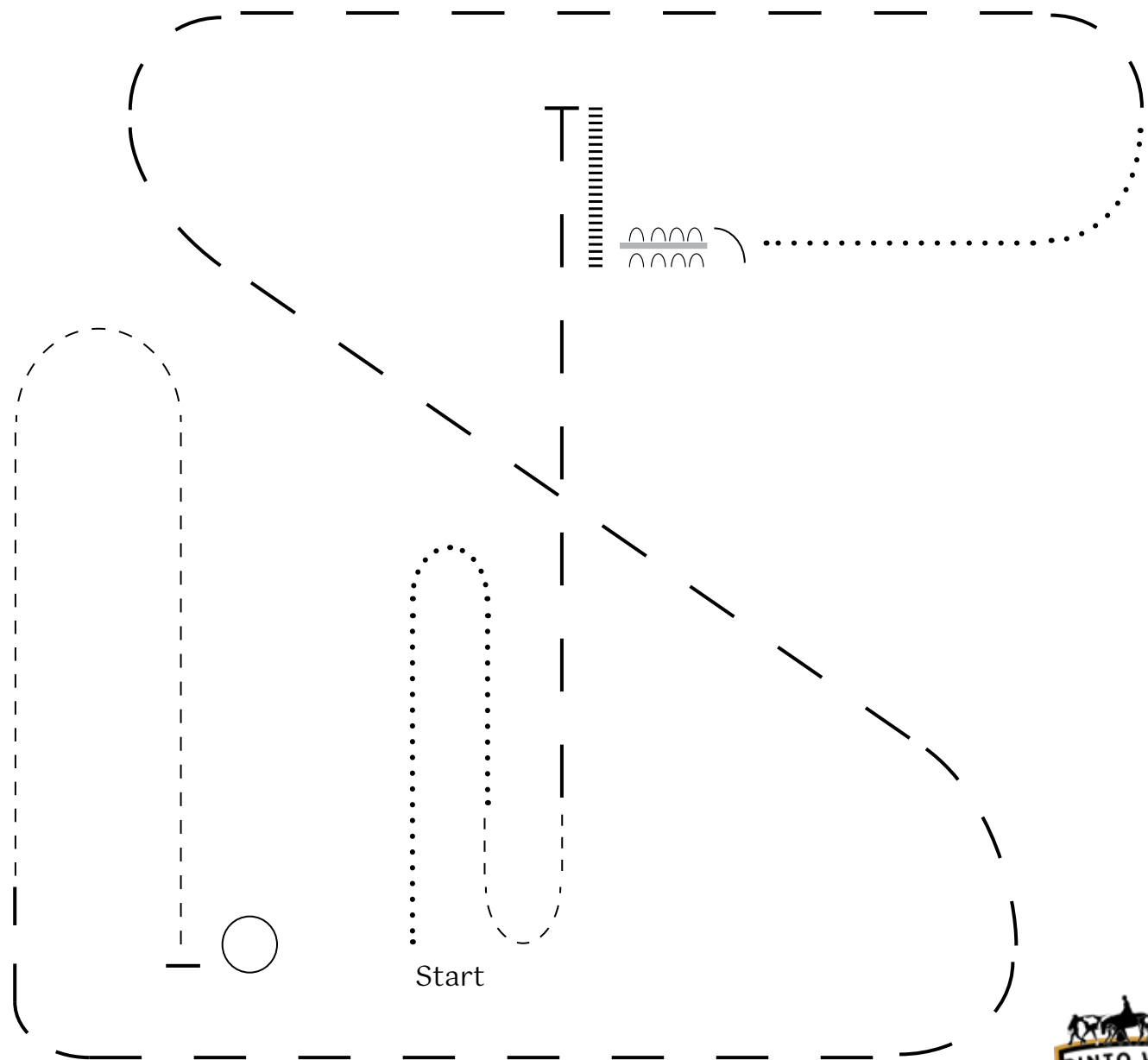

# Ranch Riding

## Classes

- 212 - AM - Ranch Riding (NSBA)
- 213 - YA - Ranch Riding Horse/Pony (NSBA)
- 216 - AM Jr - Ranch Riding, Solid (NSBA)
- 217 - AM Sr/El - Ranch Riding, Solid (NSBA)
- 218 - YA Jr - Ranch Riding, Solid Horse/Pony (NSBA)
- 219 - YA Sr - Ranch Riding, Solid Horse/Pony (NSBA)

## Instructions

### RANCH RIDING -- PATTERN #7

1. Walk
2. Trot
3. Extended trot
4. Stop and back
5. Side pass over log right
6. ¼ turn right, walk over logs
7. Walk
8. Lope left lead
9. Extended lope (left lead)
10. Collect lope, change leads (simple or flying)
11. Lope right lead
12. Trot
13. Stop, one 360 degree turn either direction

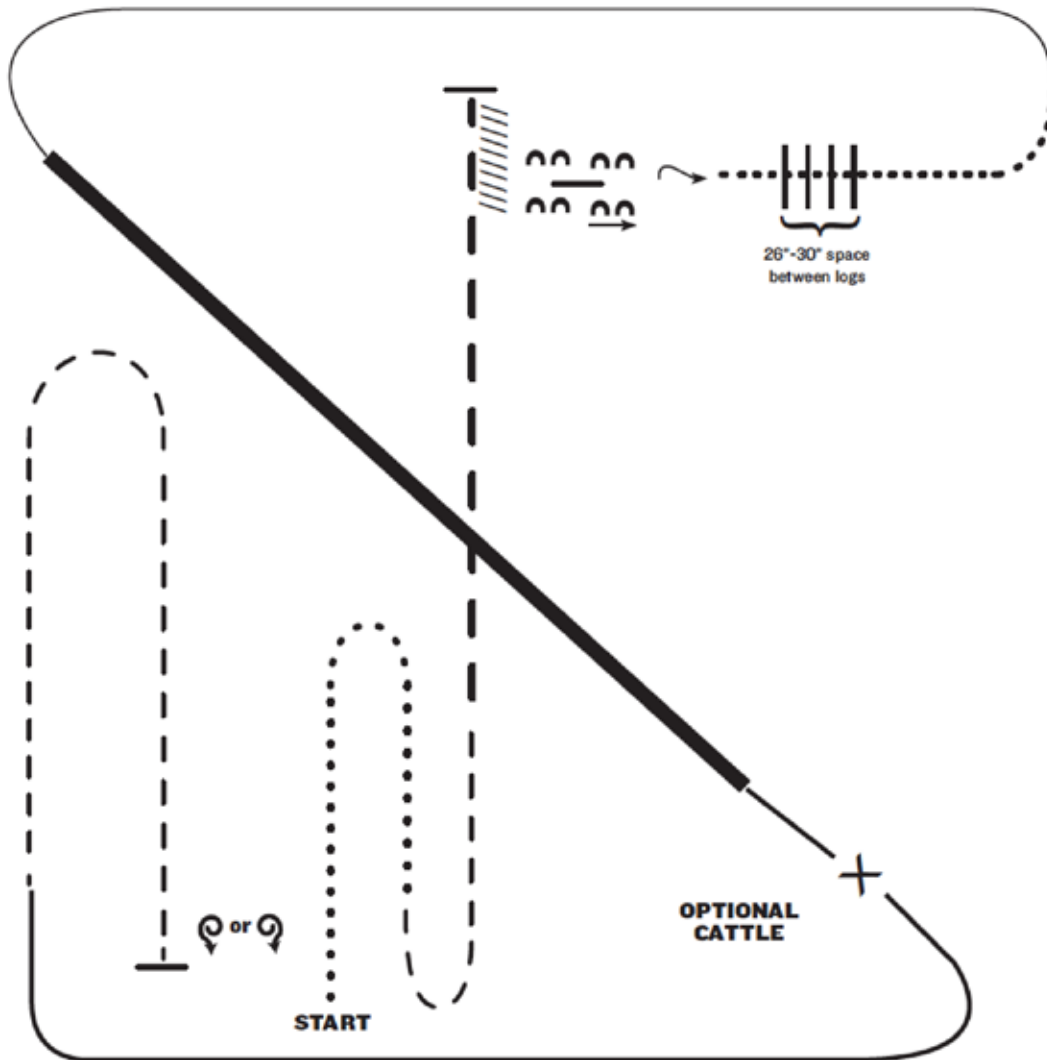

# Ranch Riding

## Classes

211 - OP - Ranch Riding, Jr. Horse (NSBA)  
214 - OP - Ranch Riding, Sr. Horse (NSBA)  
215 - OP - Ranch Riding, Jr. Solid (NSBA)  
220 - OP - Ranch Riding, Sr. Solid (NSBA)

## Instructions

RANCH RIDING -- PATTERN #13

1. Walk
2. Walk over logs
3. Trot
4. Extended trot serpentine
5. Lope right lead
6. Change leads (simple or flying)
7. Extended lope (left lead), collect lope
8. Stop, 1 1/2 turn, either direction
9. Trot
10. Walk to gate
11. Right hand push gate
12. Walk, lope left lead
13. Stop and back

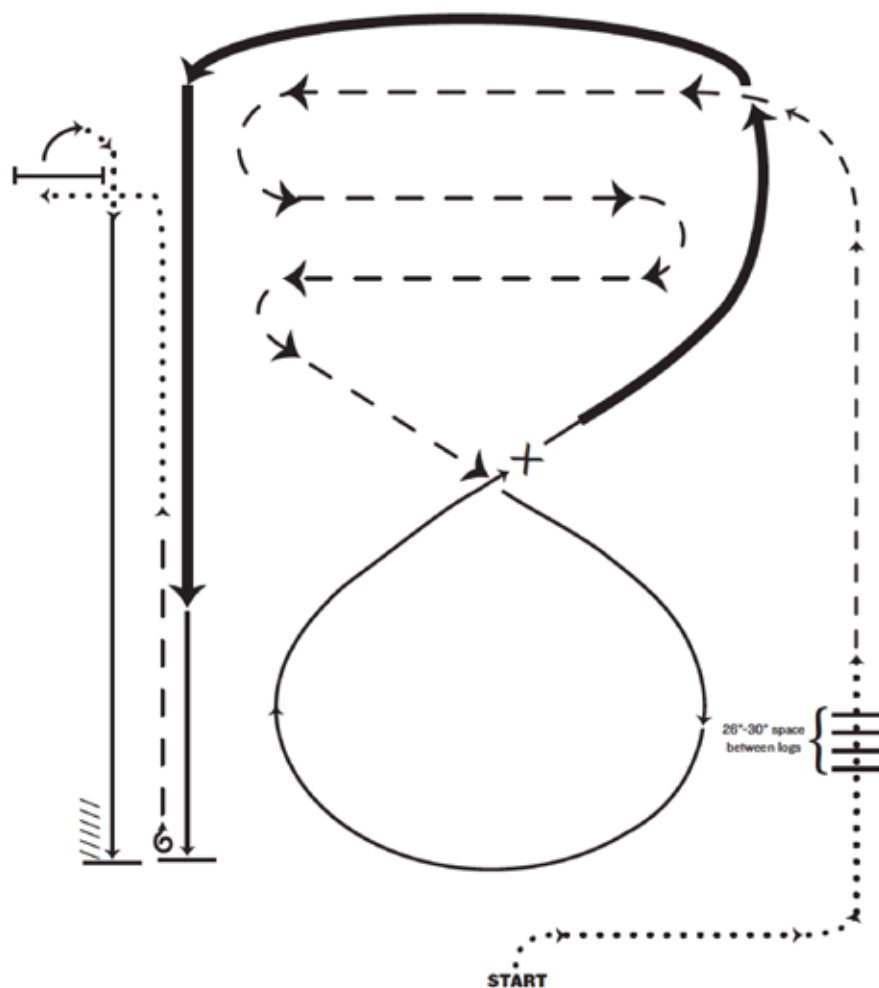

# Ranch Reining

## Classes

- 51 - OP - Ranch Reining
- 52 - OP - Ranch Reining, Solid
- 53 - YA - Ranch Reining Horse/Pony
- 54 - YA Jr - Ranch Reining, Solid Horse/Pony
- 55 - YA Sr - Ranch Reining, Solid Horse/Pony
- 56 - AM - Ranch Reining
- 57 - AM Jr - Ranch Reining, Solid
- 58 - AM Sr/El - Ranch Reining, Solid

## Instructions

### RANCH REINING #6

- Trot to center of arena and stop or walk before departure. Start pattern facing toward judge.
1. Beginning on left lead, complete two circles to the left - the first one large and fast, the second one small and slow. Change leads at center of arena.
  2. Complete two circles to the right - the first one large and fast, the second one small and slow. Change leads at center of arena.
  3. Begin a circle to the left, but do not close this circle. Continuing around the end of arena, run up the center, past end marker, and do a sliding stop.
  4. Complete 3 1/2 spins to the left.
  5. Run down to other end of arena, past the end marker, and do a sliding stop.
  6. Complete 3 1/2 spins to the right.
  7. Run past the center marker and do a sliding stop. Back at least 10 feet. Hesitate to show completion pattern

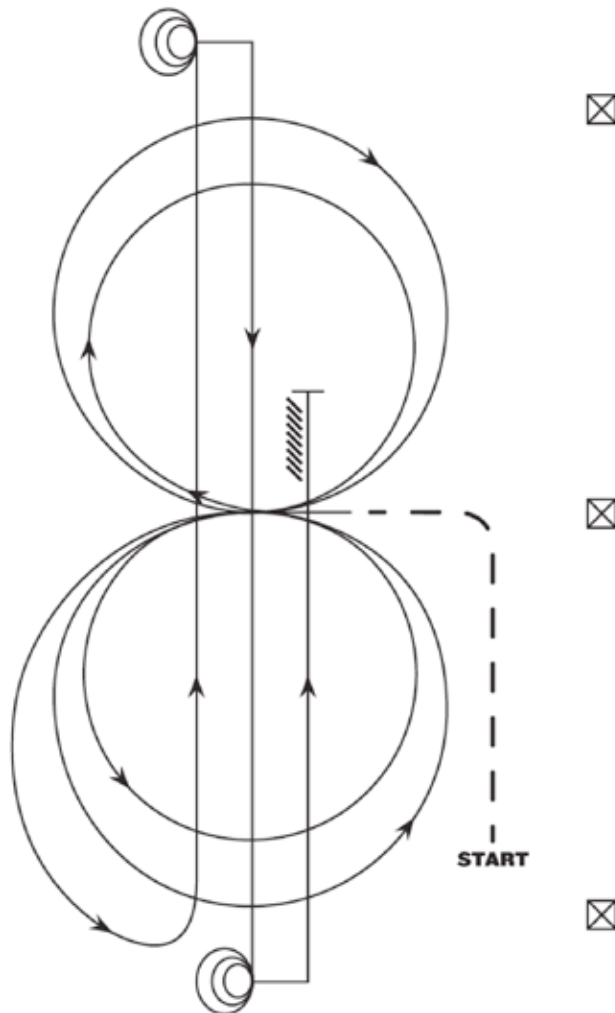

# Trail In-Hand

## Classes

- 345 - AM - Two-year Old, Horse
- 346 - AM - Two-year Old, Solid Horse
- 347 - OP - Two-year Old, Horse
- 348 -OP - Two-year Old, Solid Horse

## Instructions

1. Jog over poles, jog into chute and stop
2. Back around corner, back between poles, walk out over poles
3. Jog over poles
4. Stop or break to the walk, walk over bridge and walk over poles
5. Jog up to gate, work rope gate left hand
6. Walk forward then jog through serpentine, jog over poles
7. Jog over poles
8. Stop or break to walk, walk into box, execute a 360° turn either way, walk out of box

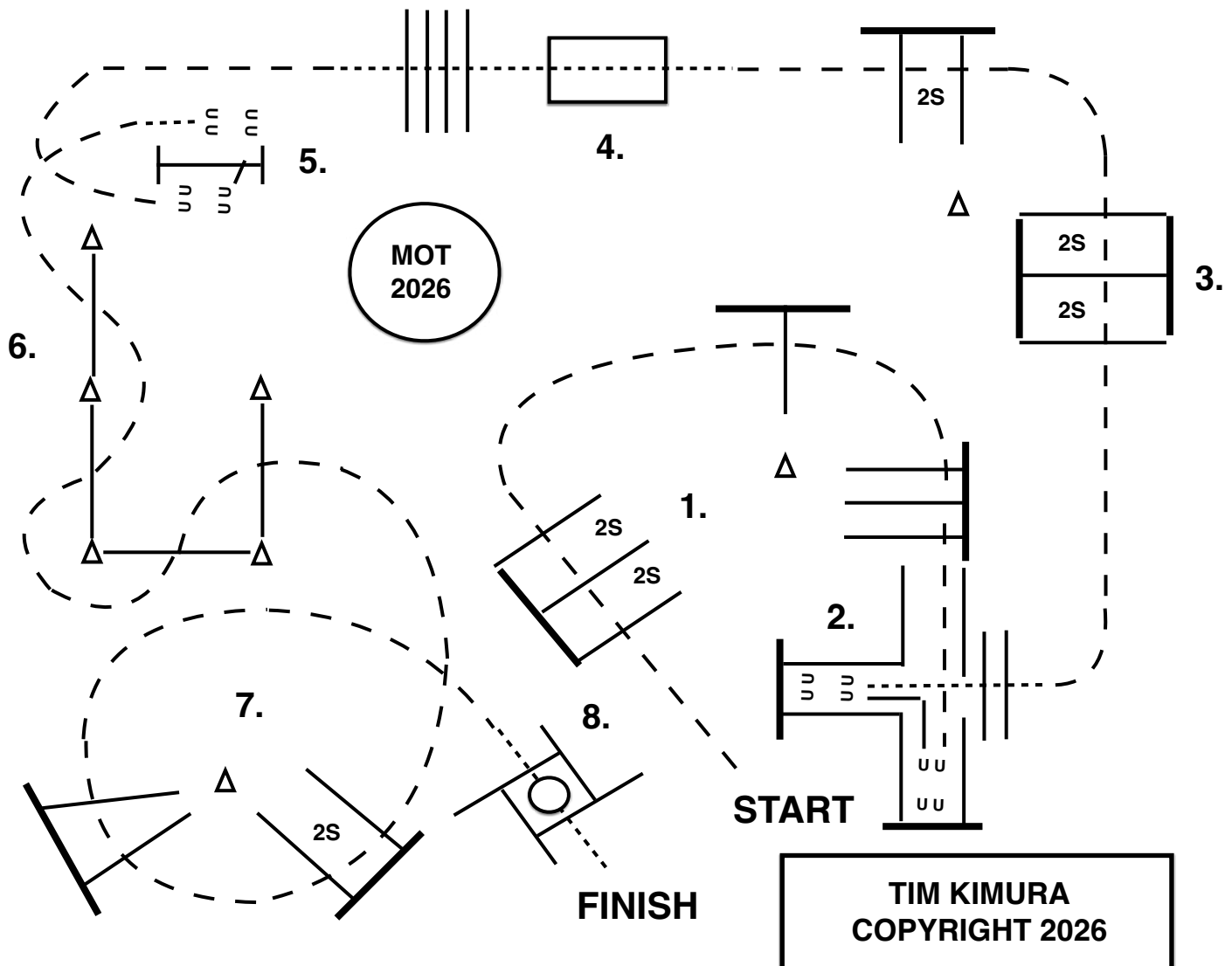

# Trail In-Hand

## Classes

## Instructions

- 550 - OP - Miniature
- 551 - OP - B Miniature
- 552 - OP - Solid Miniature/B Miniature
- 553 - AM - Miniature/B Miniature
- 554 - YA - Miniature/B Miniature
- 555 - OP - Pony
- 556 - OP - Solid Pony
- 557 - AM - Pony
- 558 - YA - Pony

1. Walk over poles, walk over bridge
2. Jog around cones, jog over poles
3. Stop or break to the walk, walk over pole, walk into chute, back around corner, walk out of chute, walk over pole
4. Jog over poles
5. Stop or break to walk, walk over poles, walk to box
6. Walk into box, execute 360° turn either way, walk out of box
7. Jog over poles
8. Jog up to cone, stop or break to walk, walk up to gate, work gate left hand

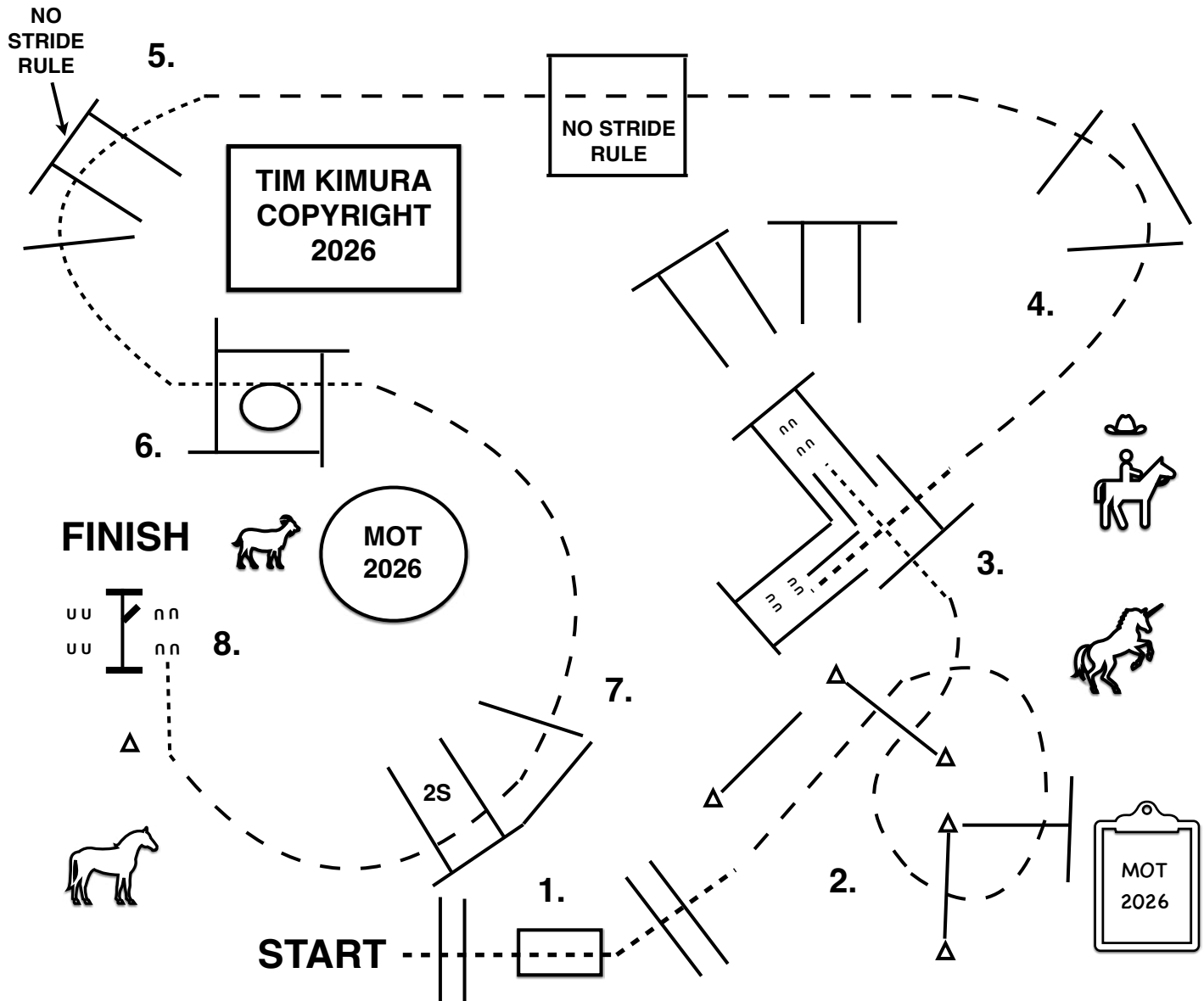

# Trail In-Hand

## Classes

- 606 - AM - Yearling Horse
- 607 - AM - Yearling Solid Horse
- 608 - OP - Yearling Horse
- 609 - OP - Yearling Solid Horse

## Instructions

1. Walk over poles, walk into box
2. Back out of box, walk around corner
3. You may walk forward, jog out and jog over poles
4. Jog through serpentine, jog over poles
5. Stop or break to walk, walk into box, execute 360° turn to the right, walk out of box
6. Jog over poles up and back
7. Stop or break to the walk, walk over poles, walk up to gate
8. Work gate left hand

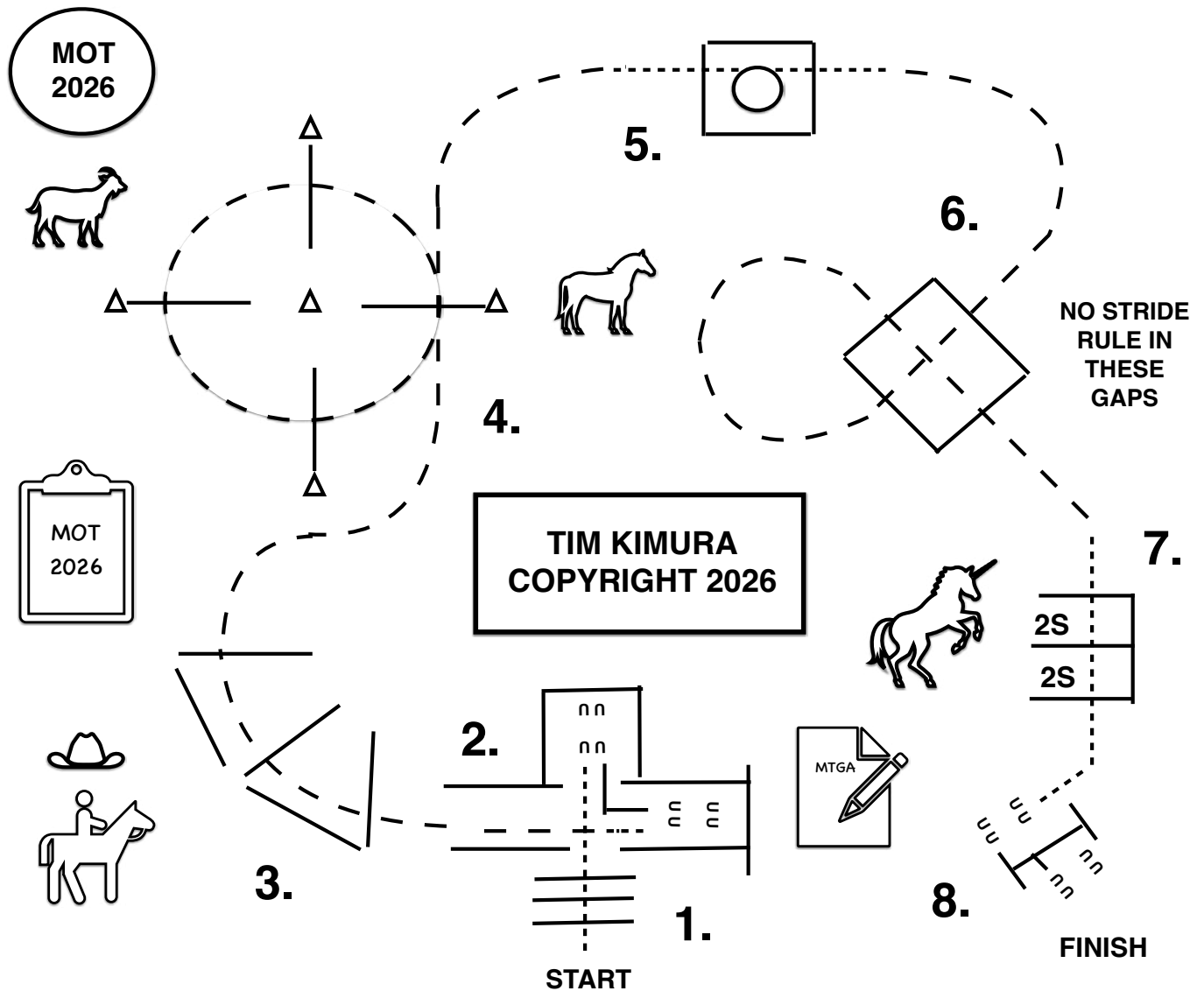

# Trail

## Classes

280 - YA Jr - Trail, English, Horse/Pony  
 281 - YA Sr - Trail, English, Horse/Pony  
 282 - YA - Trail, English, Solid Horse/Pony  
 283 - AM Jr - Trail, English  
 284 - AM Sr - Trail, English  
 285 - AM Elite - Trail, English  
 286 - AM - Trail, English, Solid  
 296 - OP - Trail, English  
 297 - OP - Trail, English, Solid

## Instructions

1. Walk into box, execute a 360° turn either way, walk out of box
2. Walk over poles
3. Canter over poles, left lead
4. Break to the trot, trot over poles
5. Canter over poles, right lead
6. Break to the trot, trot through serpentine, trot over pole
7. Canter over poles, right lead
8. Break to the trot, trot into chute, back to gate
9. Work gate, right hand
10. You may walk forward, then trot over poles and finish

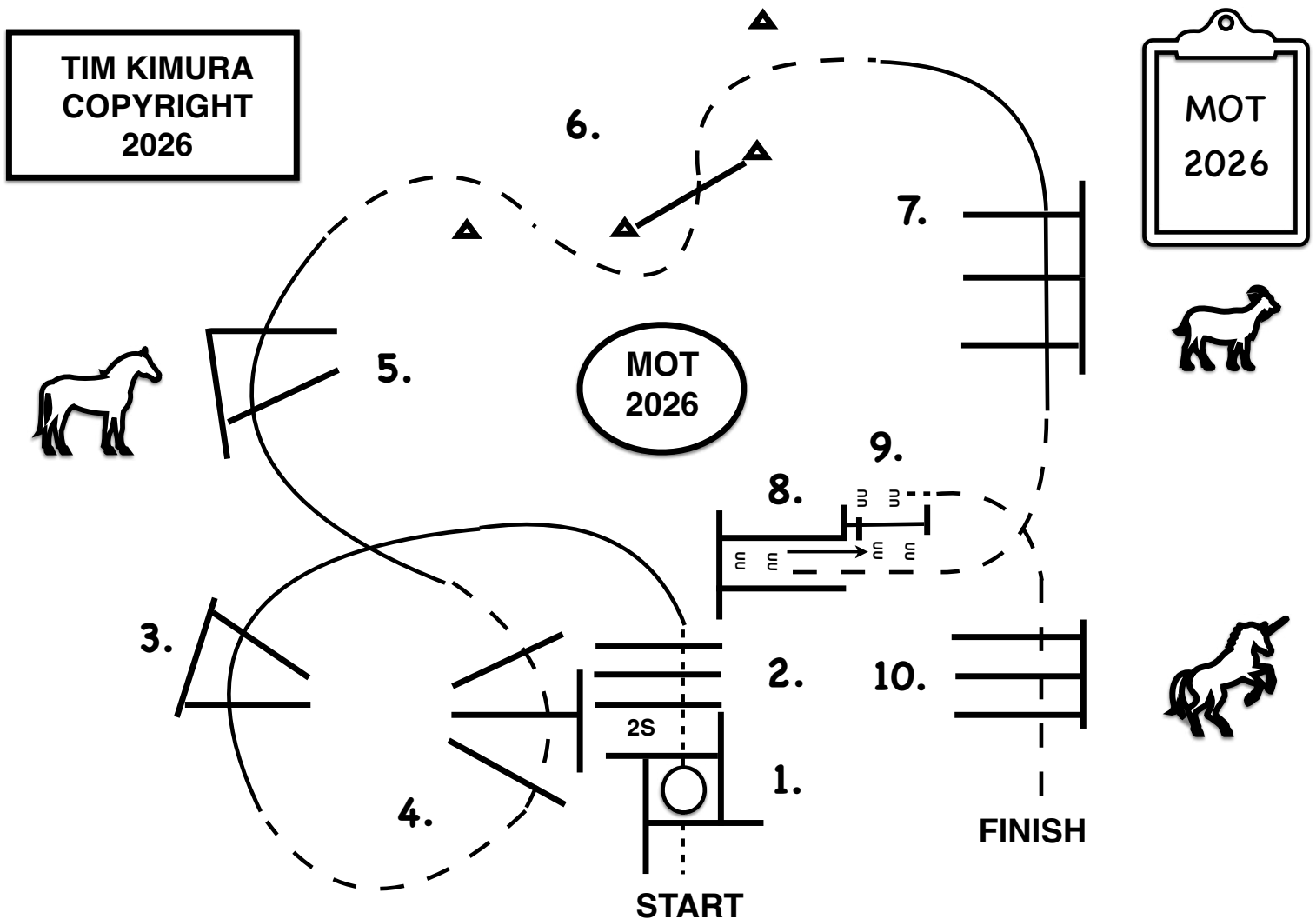

# Trail

## Classes

## Instructions

- 292 - YA Walk/Trot 11-18, English Horse/Pony
- 293 - YA Walk/Trot 11-18, English, Solid, Horse/Pony
- 294 - YA Leadline Walk/Trot, 8 & u - Trail
- 295 - YA Leadline Walk/Trot, 8 & u - Trail, Solid

1. Walk through box
2. Walk over poles
3. Trot over poles
4. Trot over poles
5. Stop or break to the walk, walk over poles
6. Trot serpentine, trot over pole
7. Trot over poles
8. Trot into chute, back to open gate
9. Walk through gate and over poles

**TIM KIMURA  
COPYRIGHT  
2026**

**MOT  
2026**

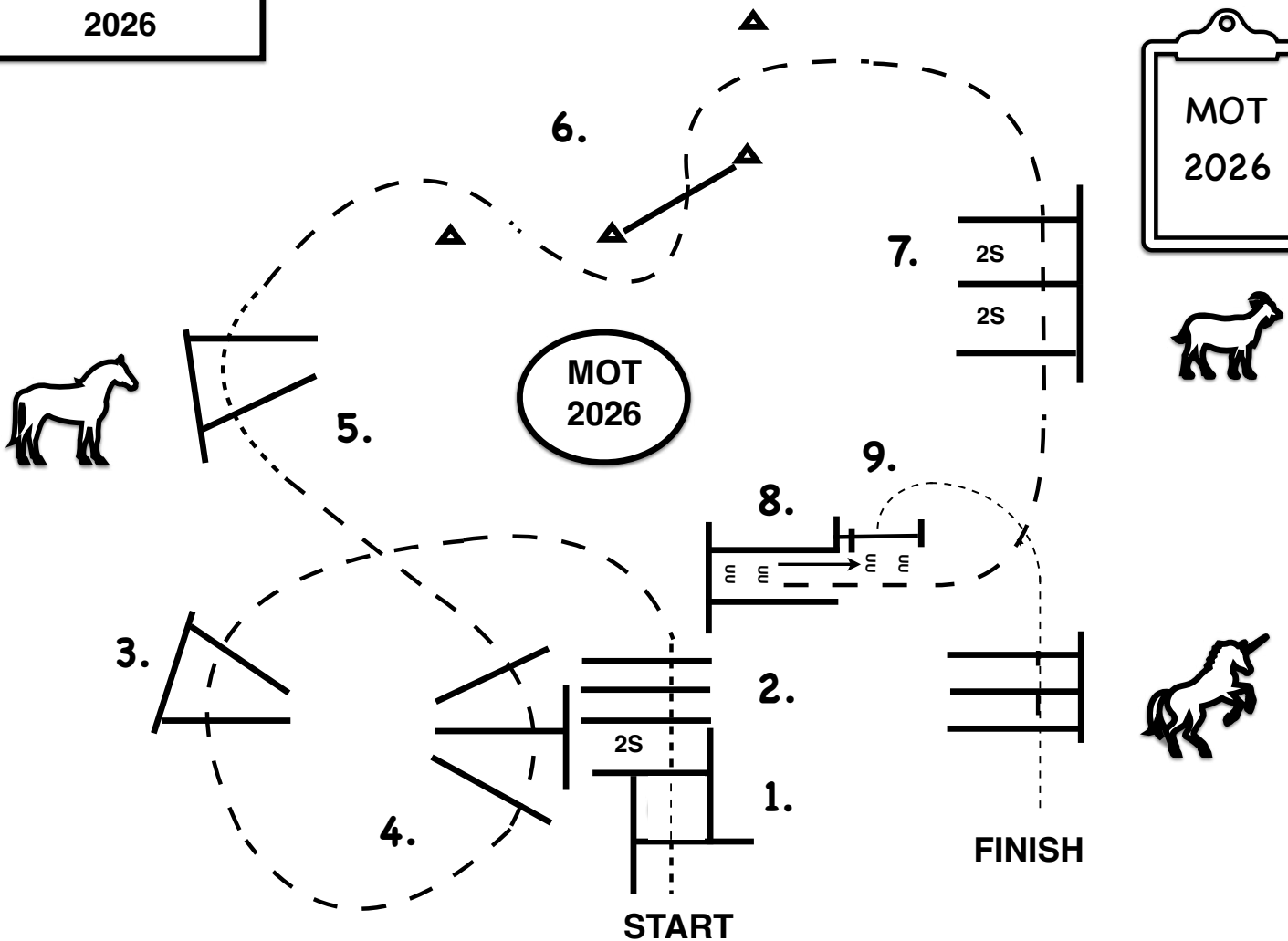

# Trail

## Classes

- 287 - AM JR Walk/Trot, English
- 288 - AM SR Walk/Trot, English
- 289 - AM Elite Walk/Trot, English
- 290 - AM JR Walk/Trot, English, Solid
- 291 - AM SR/Elite Walk/Trot, English, Solid

## Instructions

1. Walk into box, execute 360° turn either way, walk out of box
2. Walk over poles
3. Trot over poles
4. Trot over poles
5. Stop or break to walk, walk over poles
6. Trot through serpentine, trot over pole
7. Trot over poles
8. Trot into chute, back to gate
9. Work gate right hand
10. You may walk forward, then trot over poles and finish

**TIM KIMURA  
COPYRIGHT  
2026**

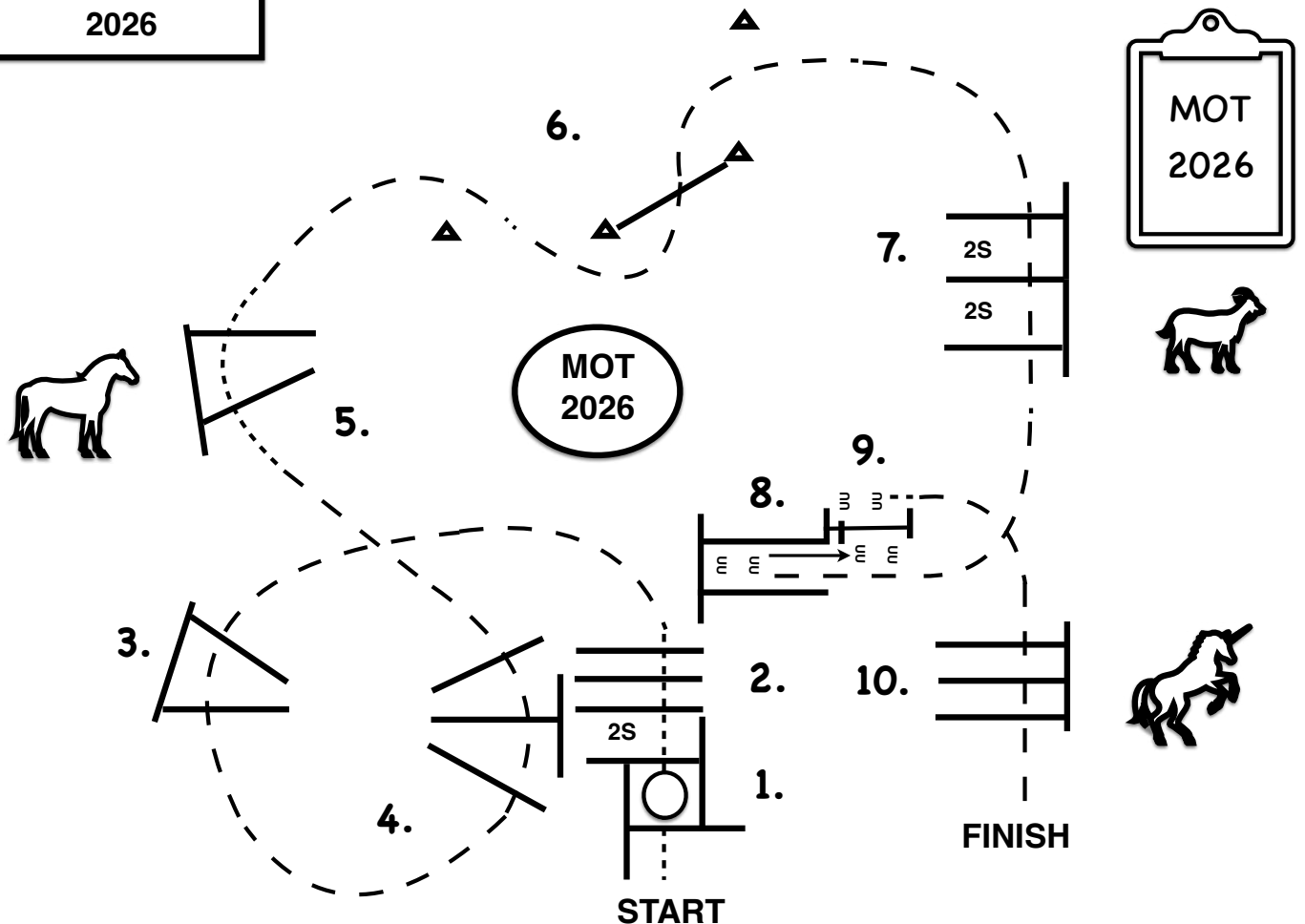

# Trail

## Classes

## Instructions

- 334 - YA Jr - Trail - Western, Horse/Pony (NSBA)
- 335 - YA Sr - Trail - Western, Horse/Pony (NSBA)
- 336 - YA Jr Novice - Trail, Horse/Pony
- 337 - YA Sr Novice - Trail, Horse/Pony
- 338 - YA Jr - Trail - Western, Solid Horse/Pony (NSBA)
- 339 - YA Sr - Trail - Western, Solid Horse/Pony (NSBA)
- 340 - YA Novice - Trail - Western, Solid Horse/Pony

1. Jog over poles
2. Jog over poles, jog into chute and stop
3. Back around corner, back between poles, walk out over poles
4. Lope over poles, left lead
5. Stop or break to the walk, walk over bridge
6. Walk over poles
7. Jog up to gate, work rope gate left hand
8. Walk forward then jog through serpentine, jog over poles
9. Lope over poles, right lead
10. Stop or break to walk, walk into box, execute a 360° turn either way, walk out of box

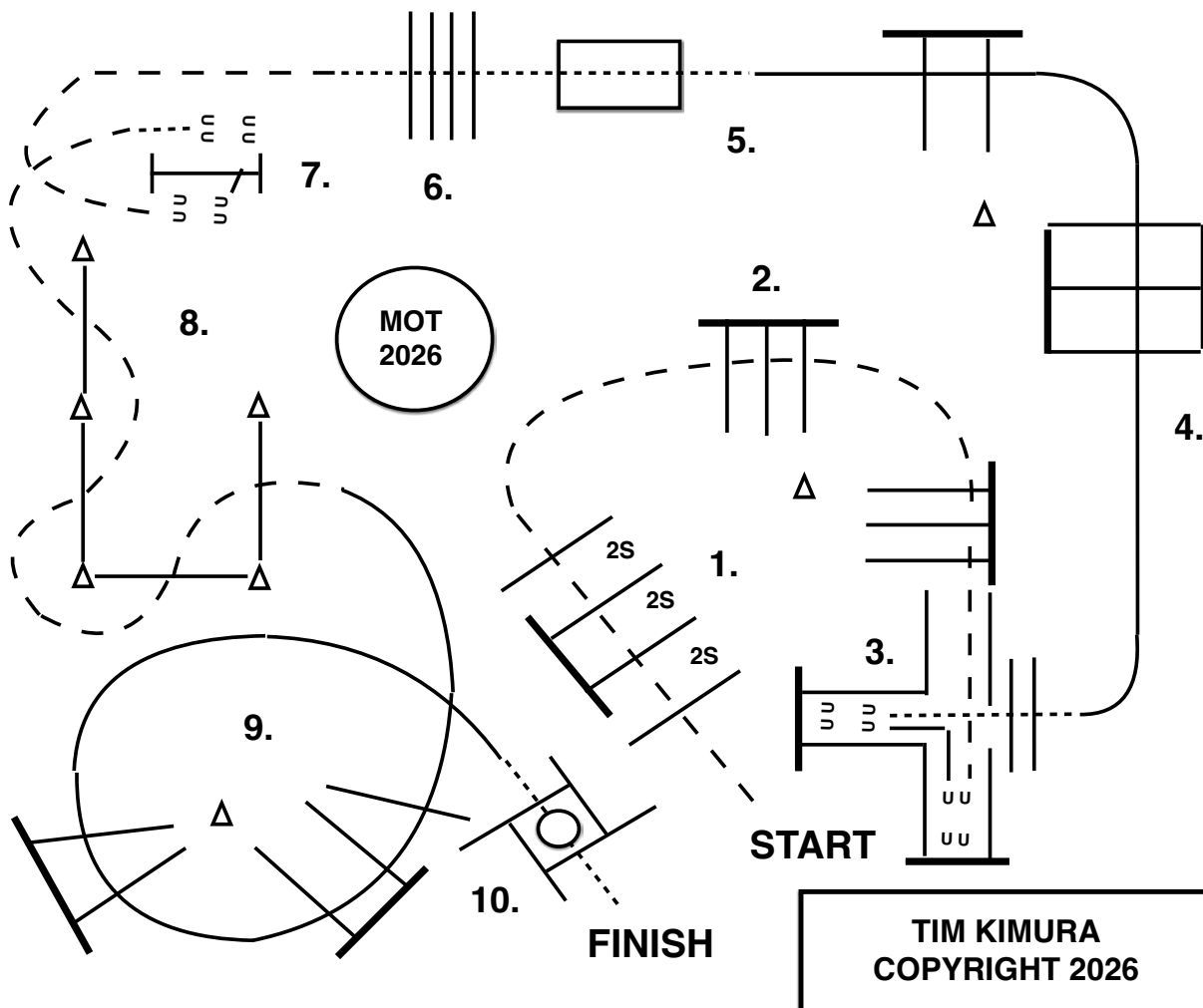

# Trail

## Classes

- 341 - YA W/T, 11 - 18 yo - Trail, Western, Horse/Pony
- 342 - YA /T, 11 - 18 yo - Trail, Western, Solid Horse/Pony
- 343 - YA W/T, 10 & u - Trail, Western, Horse/Pony
- 344 - YA W/T, 10 & u - Trail, Western, Solid Horse/Pony

## Instructions

1. Jog over poles
2. Jog over poles, jog into chute and stop
3. Back around corner, back between poles, walk out over poles
4. Jog over poles
5. Stop or break to the walk, walk over bridge
6. Walk over poles
7. Jog up to gate, work rope gate left hand
8. Walk forward then jog through serpentine, jog over poles
9. Jog over poles
10. Stop or break to walk, walk into box, execute a 360° turn either way, walk out of box

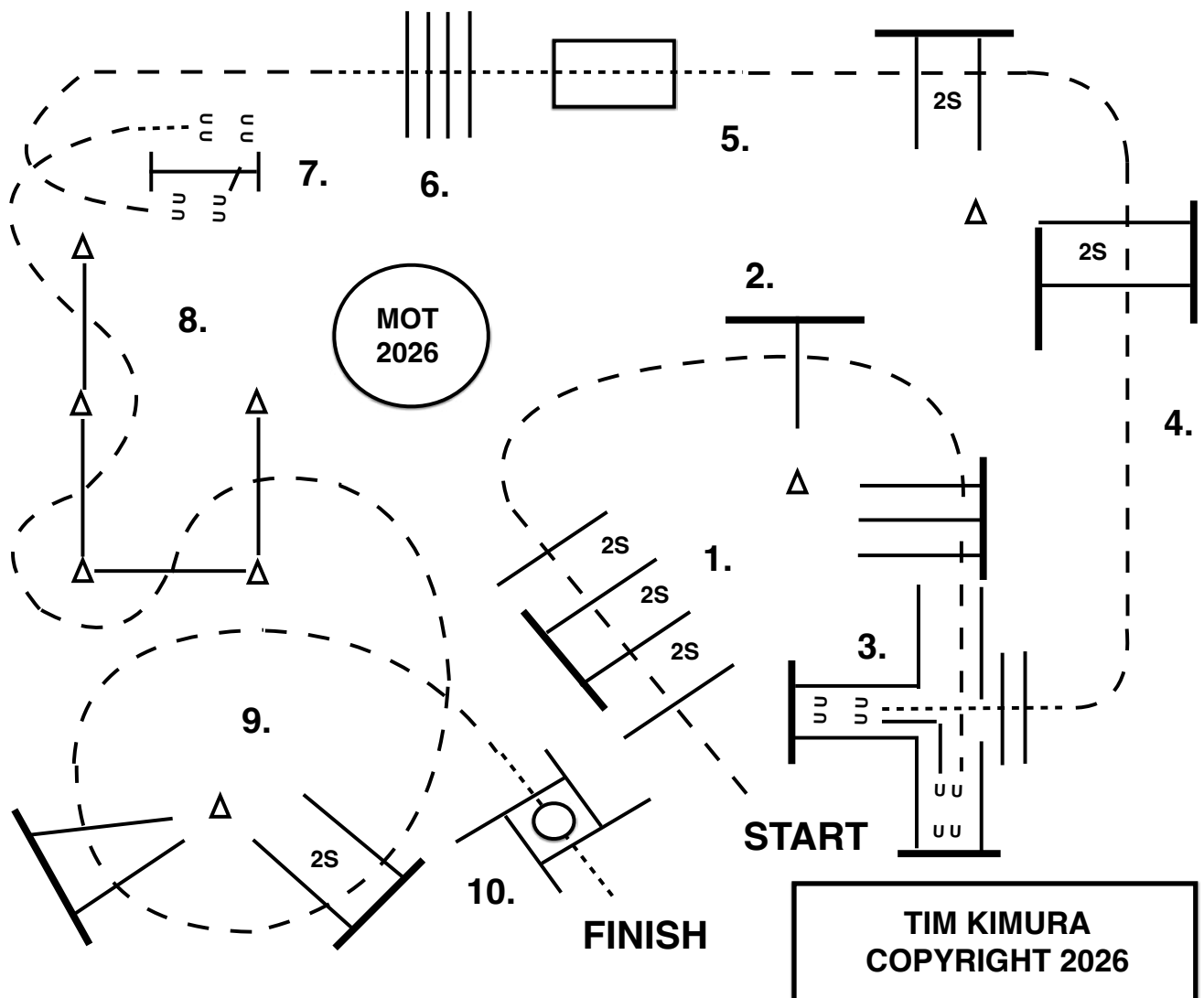

# Trail

## Classes

- 417 - OP - Trail-Western, 5 & Under (NSBA)
- 418 - OP - Trail-Western, 6 & Over (NSBA)
- 419 - OP - Trail - Western, 5 & Under, Solid (NSBA)
- 420 - OP - Trail - Western, 6 & Over, Solid (NSBA)

## Instructions

1. Lope over poles, right lead
2. Break to the jog, jog over poles
3. Stop or break to the walk, walk into box, execute 360° turn either way, walk out of box
4. Lope over poles, left lead
5. Break to the jog, jog over poles
6. Lope over poles, left lead
7. Break to the jog, jog over pole, stop, back "L"
8. Walk out of chute, walk over poles
9. Jog through serpentine, jog over poles
10. Jog over poles, jog to gate, stop and work gate, left hand

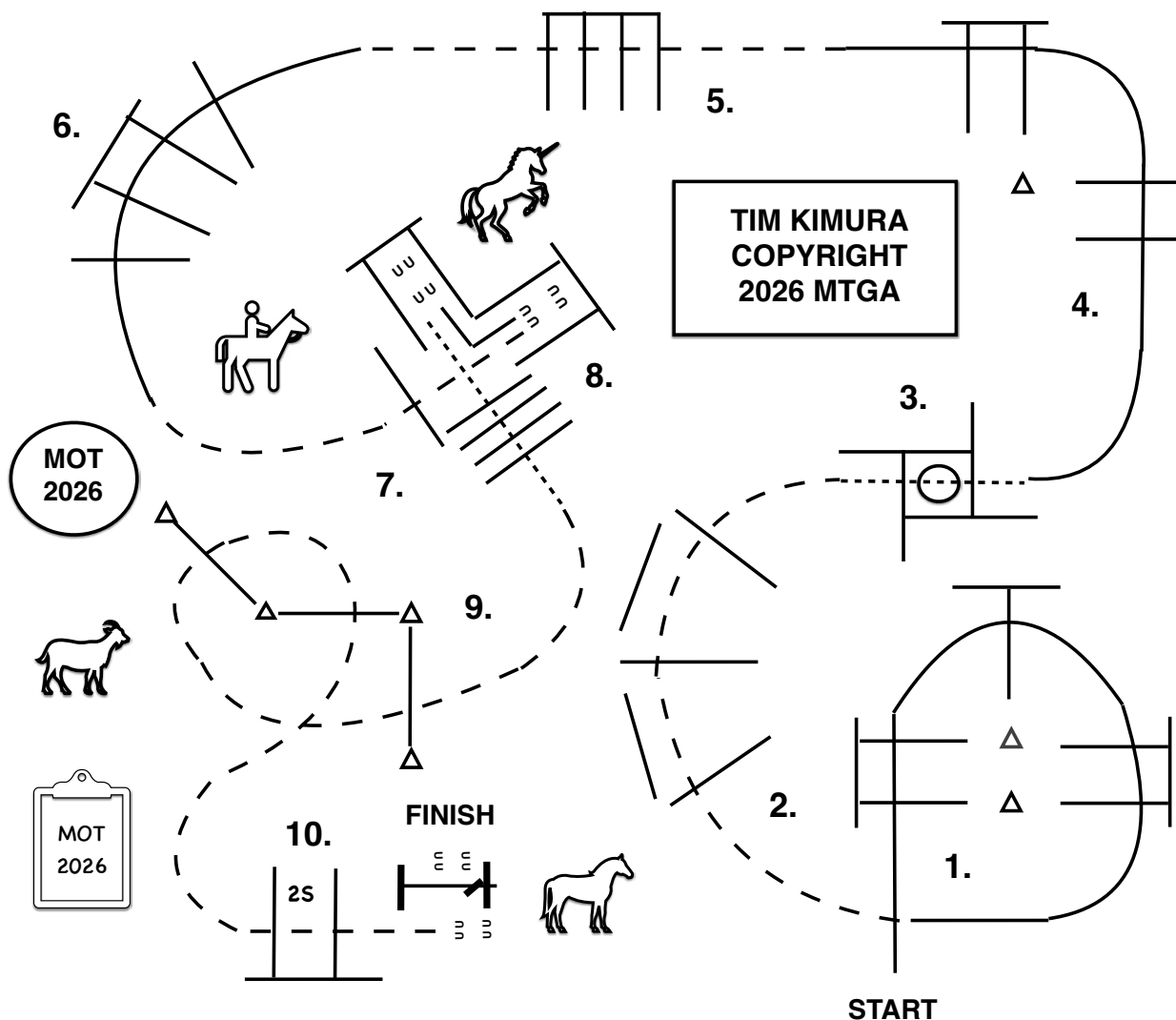

# Trail

## Classes

## Instructions

412 - AM Sr/EI Walk/Trot - Trail, Solid

1. Jog over poles
2. Jog over poles
3. Stop or break to the walk, walk into box, execute 360° turn either way, walk out of box
4. Jog over poles
5. Stop or break to the walk, walk over poles
6. Jog over poles
7. Break to the walk, walk over pole, stop, back "L" between poles
8. Walk out of chute, walk over poles
9. Jog through serpentine, jog over poles
10. Jog over poles, jog to gate, stop and work gate, left hand

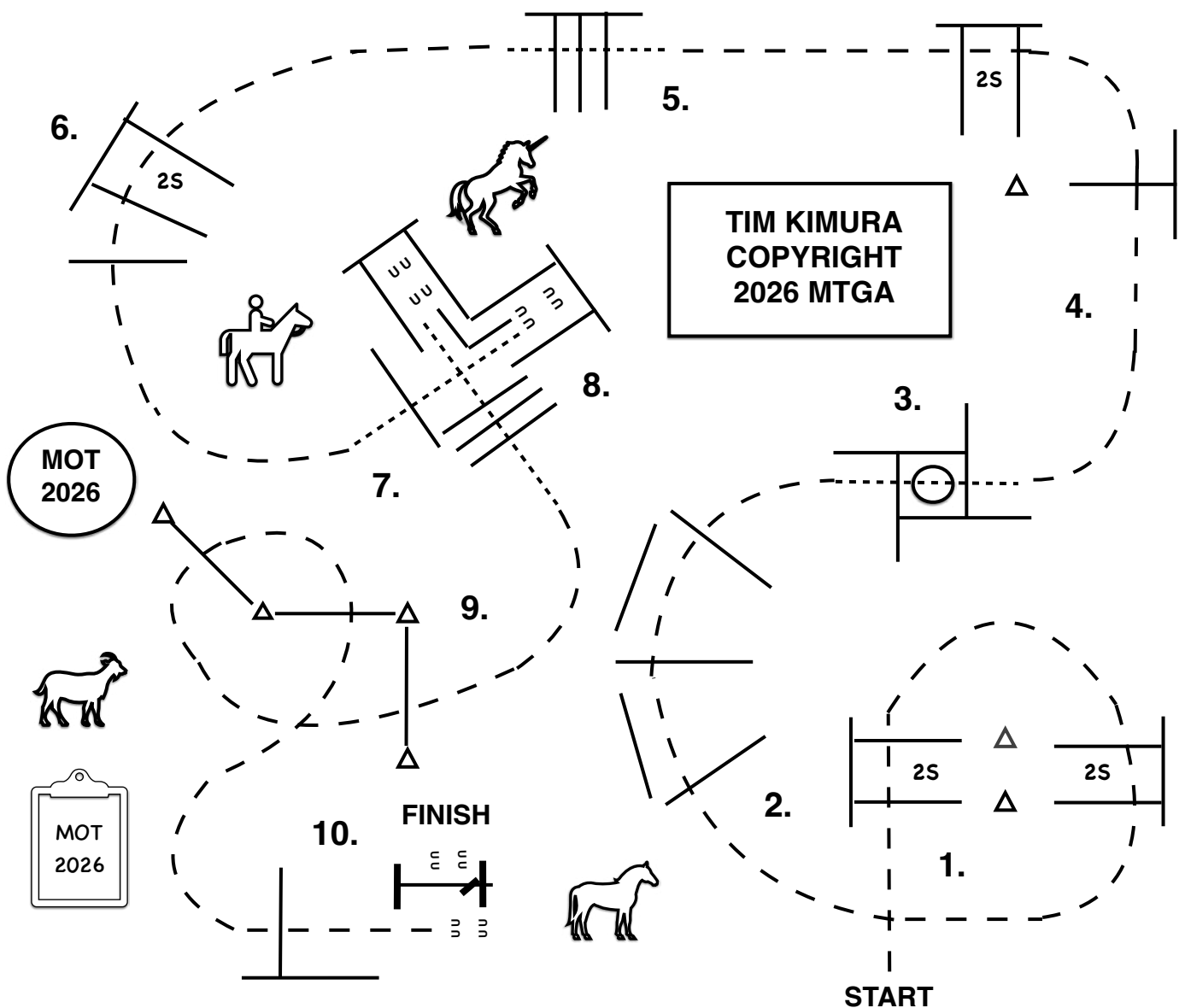

# Trail

## Classes

- 413 - OP - Green Trail - Western
- 414 - OP - Green Trail, Western - Solid
- 415 - AM Jr- Trail - Western - Solid (NSBA)
- 416 - AM Sr/El - Trail - Western - Solid (NSBA)

## Instructions

1. Lope over poles, right lead
2. Break to the jog, jog over poles
3. Stop or break to the walk, walk into box, execute 360° turn either way, walk out of box
4. Lope over poles, left lead
5. Break to the jog, jog over poles
6. Lope over poles, left lead
7. Break to the jog, jog over pole, stop, back "L" between poles
8. Walk out of chute, walk over poles
9. Jog through serpentine, jog over poles
10. Jog over poles, jog to gate, stop and work gate, left hand

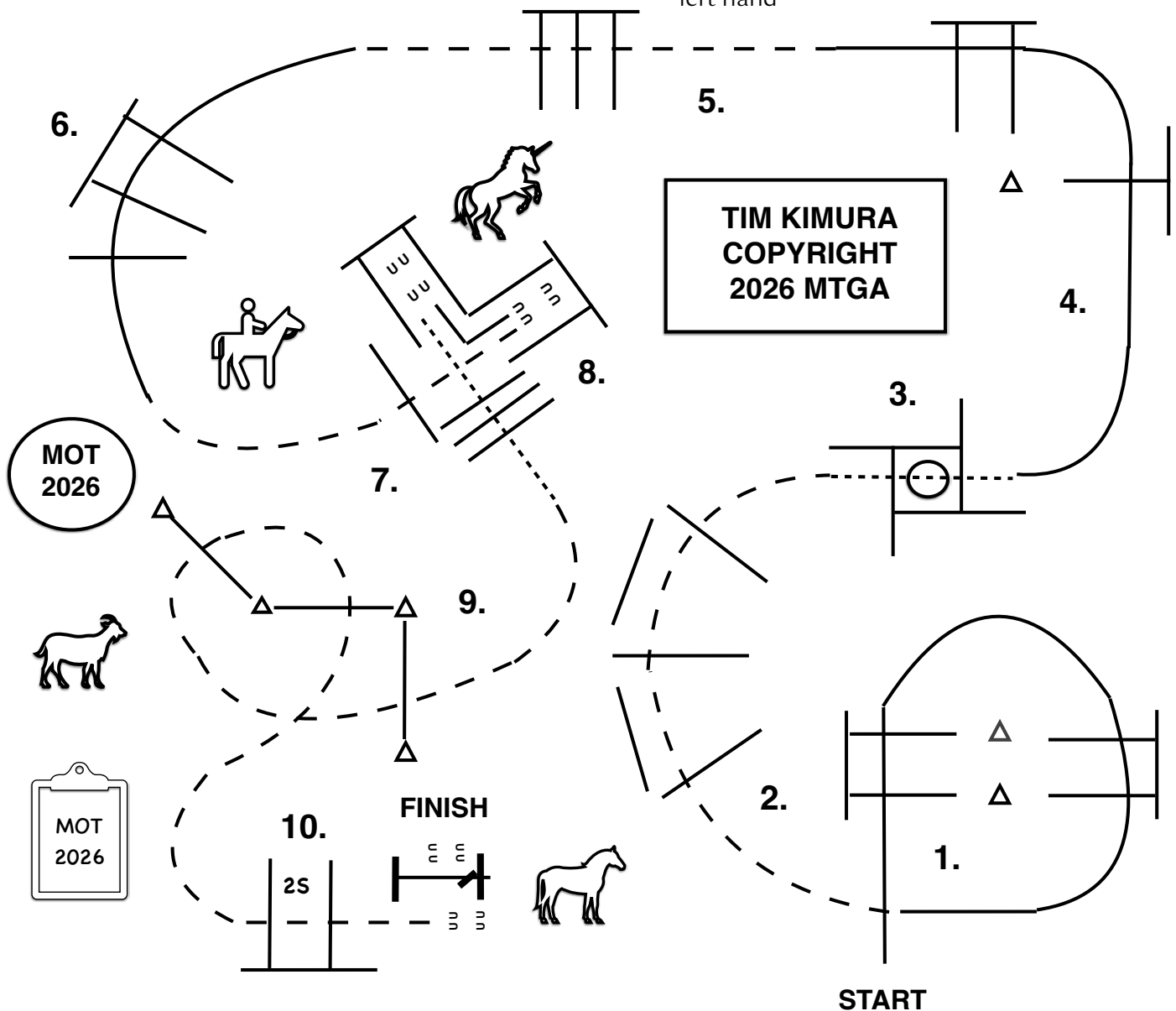

# Trail

## Classes

## Instructions

483 - AM Novice - Trail, Solid

1. Work gate, right hand
2. You may walk forward, then lope over poles, right lead
3. Break to the jog, jog over poles
4. Stop or break to the walk, walk over poles
5. Jog over poles
6. Jog through serpentine, jog over poles
7. Stop or break to the walk, walk over poles
8. Lope over poles, left lead
9. Break to the jog, jog over pole and jog into chute, back around corner and back between poles into box
10. Execute a 360° turn either way, walk out of chute, walk over pole

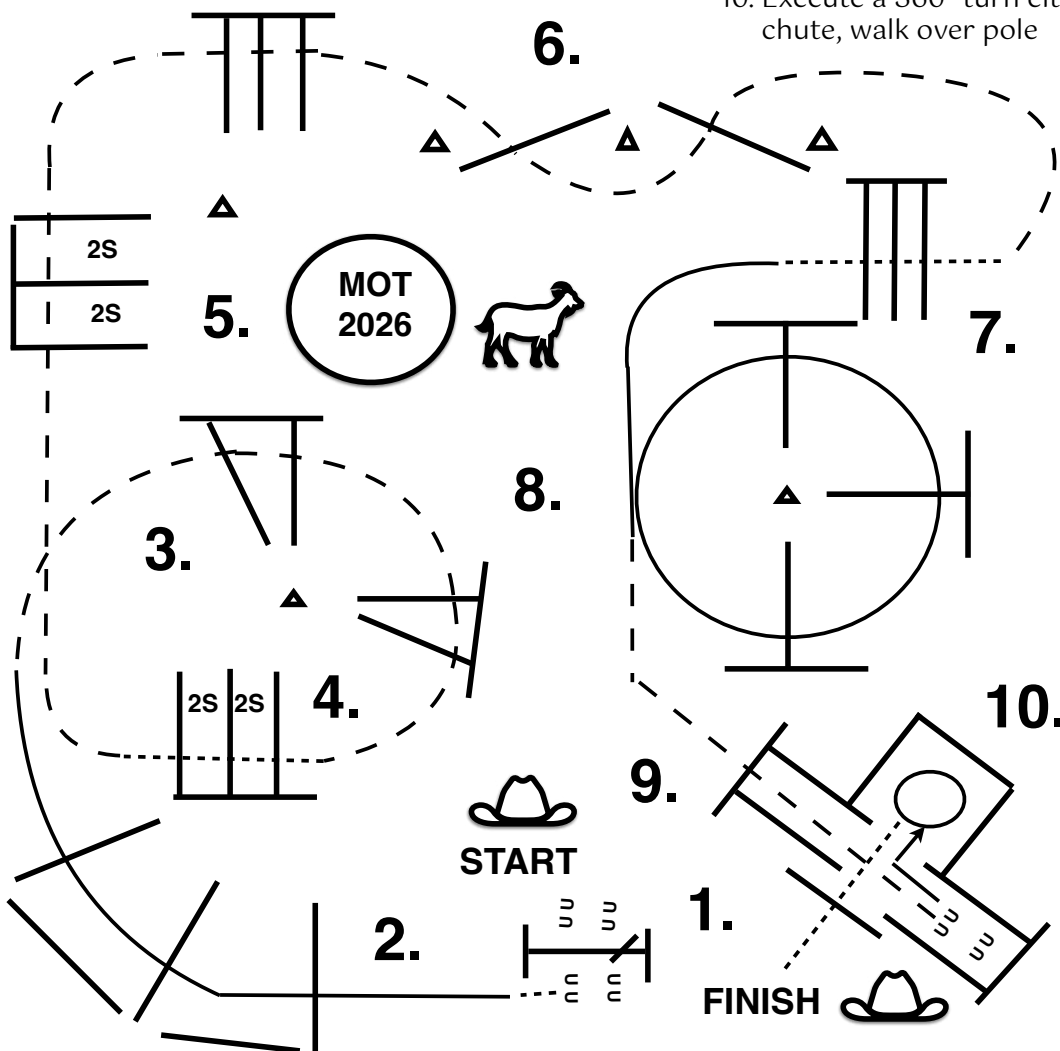

**TIM KIMURA COPYRIGHT 2026**

# Trail

## Classes

## Instructions

479 - AM Jr Walk/Trot - Trail, Solid  
 480 - AM Jr Walk/Trot - Trail  
 481 - AM Sr Walk/Trot - Trail  
 482 - AM El Walk/Trot - Trail

1. Work gate, right hand
2. You may walk forward, then jog over poles
3. Jog over poles
4. Stop or break to the walk, walk over poles
5. Jog over poles
6. Jog through serpentine, jog over poles
7. Stop or break to the walk, walk over poles
8. Jog over poles
9. Jog over pole and jog into chute, back around corner and back between poles into box
10. Execute a 360° turn either way, walk out of chute, walk over pole

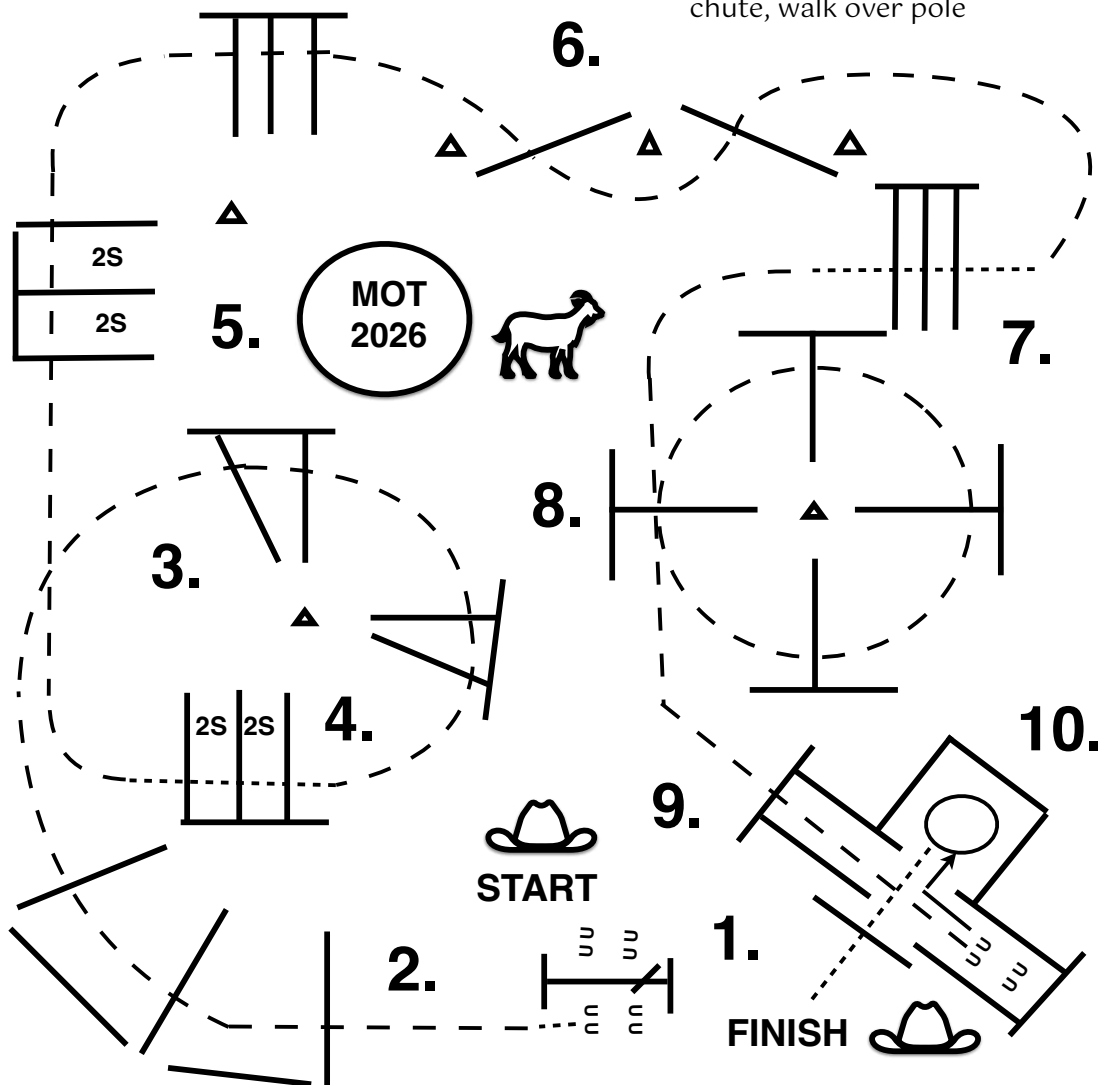

**TIM KIMURA COPYRIGHT 2026**

# Trail

## Classes

546 - AM Elite - Trail - Western, (NSBA)  
 547 - AM Sr - Trail - Western, (NSBA)  
 548 - AM Jr - Trail - Western, (NSBA)

## Instructions

1. Walk over poles, walk over bridge
2. Jog around cones, jog over poles
3. Lope over poles, right lead
4. Break to the jog, jog over poles, jog into chute, back around corner, walk out of chute, walk over pole
5. Jog over poles
6. Lope over poles, left lead
7. Break to the jog, jog over poles
8. Stop or break to walk, walk into box, execute 360° turn either way, walk out of box
9. Lope over poles, right lead
10. Lope up to cone, stop or break to walk, walk up to gate, work gate left hand

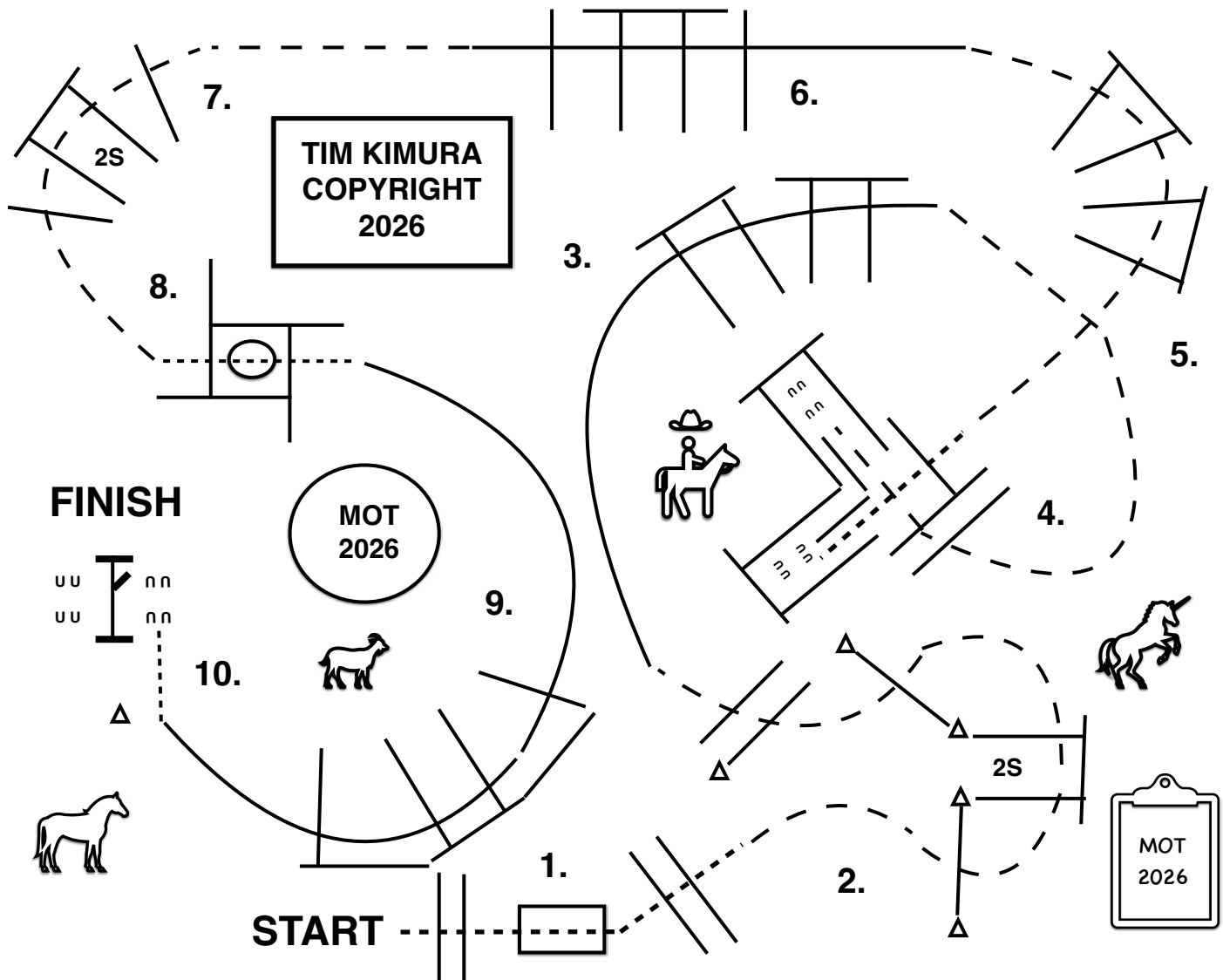

# Trail

## Classes

## Instructions

549 - AM Novice - Trail

1. Walk over poles, walk over bridge
2. Jog around cones, jog over poles
3. Lope over poles, right lead
4. Break to the jog, jog over pole, jog into chute, back around corner, walk out of chute, walk over pole
5. Jog over poles
6. Lope over poles, left lead
7. Break to the jog, jog over poles
8. Stop or break to walk, walk into box, execute 360° turn either way, walk out of box
9. Lope over poles, right lead
10. Lope up to cone, stop or break to walk, walk up to gate, work gate left hand

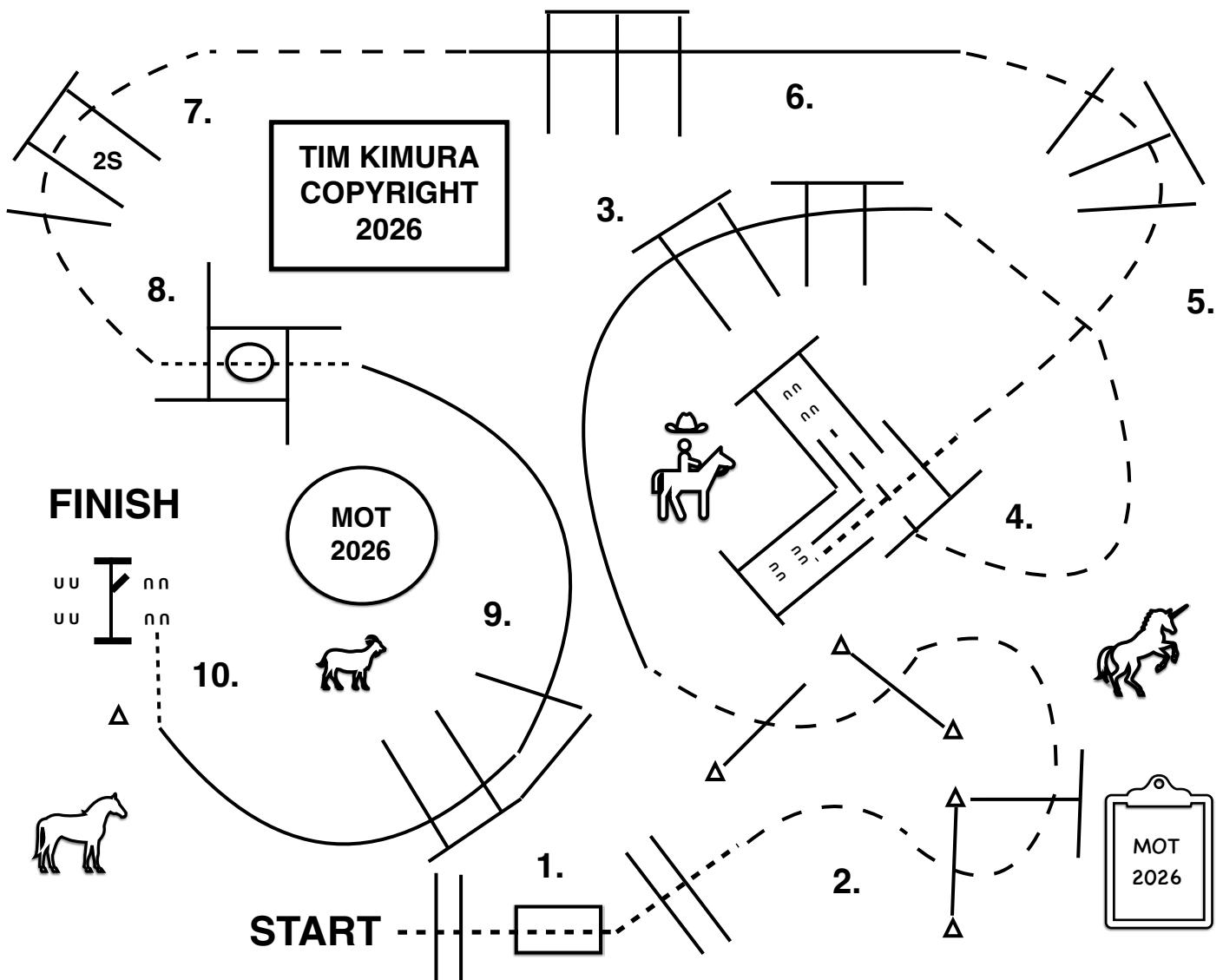

# Ranch Trail

## Classes

- 166 - YA Walk/Trot 11 - 18 - Ranch Trail, H/P
- 167 - YA Walk/Trot 11 - 18 - Ranch Trail, Solid H/P
- 168 - YA Walk/Trot 10 & u - Ranch Trail, H/P
- 169 - YA Walk/Trot 10 & u - Ranch Trail, Solid H/P
- 170 - AM Walk/Trot - Ranch Trail
- 171 - AM Walk/Trot - Ranch Trail, Solid

## Instructions

1. Extended trot, stop
2. Sidepass left over log
3. Back through chutes
4. Extended trot through gate and over pole
5. Trot to upright pole
6. Pick up object, walk the circle, rehang the object
7. Trot circle over poles
8. Trot serpentine and through standards
9. Walk over poles and bridge and to box
10. Dismount, ground tie, walk over and ring the bell
11. Return to your horse and lead out at a walk

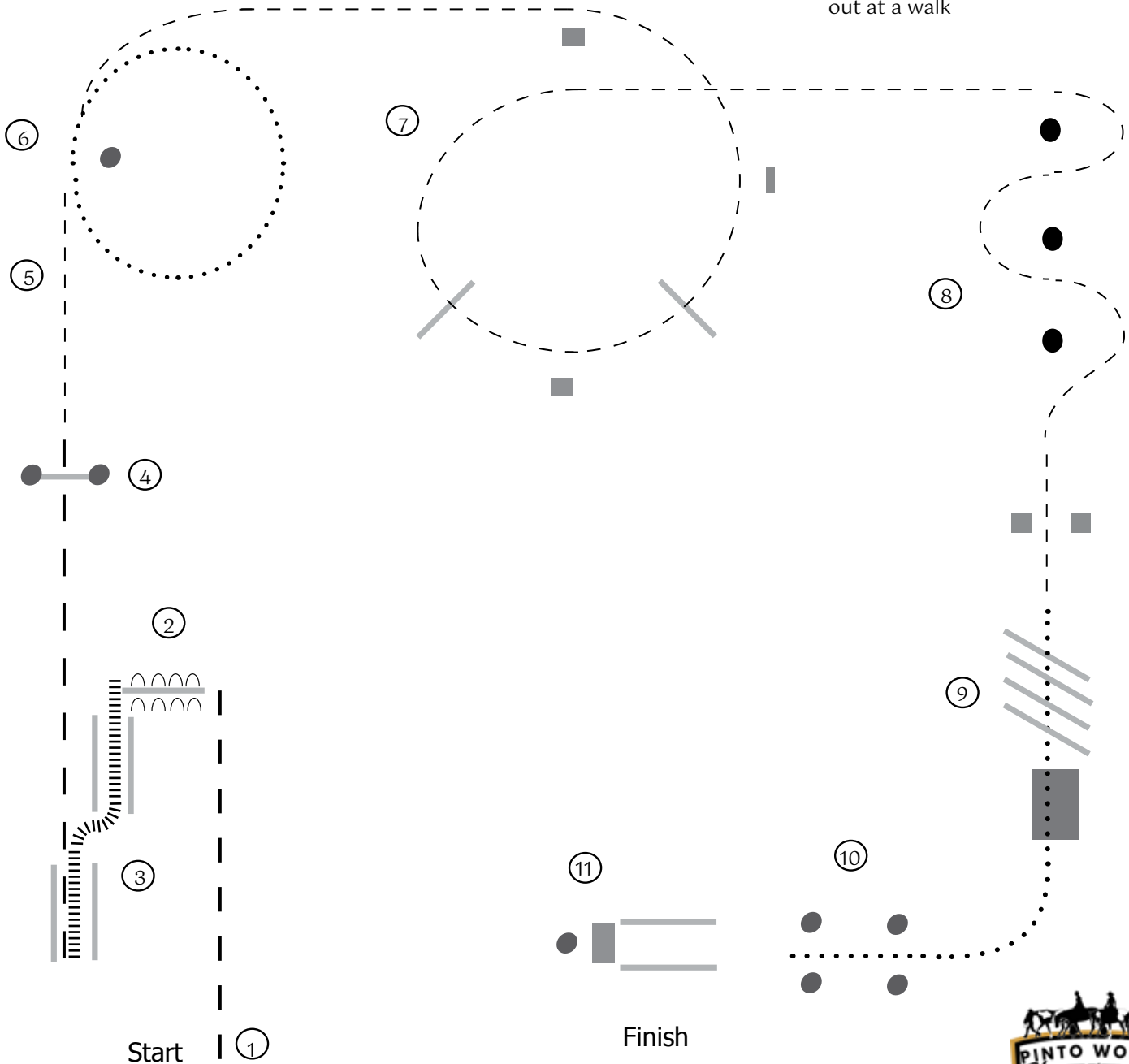

- |    |      |       |          |         |               |       |
|----|------|-------|----------|---------|---------------|-------|
| 54 | Walk | ..... | Trot     | - - - - | Extended Trot | — — — |
|    | Lope | ————  | Sidepass | ∩∩∩∩    | Back          |       |



# Ranch Trail

## Classes

- 160 - YA - Ranch Trail, Horse/Pony (NSBA)
- 161 - YA Jr - Ranch Trail, Solid H/ (NSBA)
- 162 - YA Sr - Ranch Trail, Solid H/P (NSBA)
- 163 - AM - Ranch Trail (NSBA)
- 164 - AM Jr - Ranch Trail, Solid (NSBA)
- 165 - AM Sr/EI - Ranch Trail, Solid (NSBA)

1. Lope left lead, stop
2. Sidepass left over log
3. Back through chutes
4. Extended trot to gate
5. Work gate, left hand push
6. Trot to pole, stop

## Instructions

7. Pick up object, walk the circle, rehang the object
8. Lope, right lead, over poles
9. Lope over jump
10. Walk over poles and bridge and to box
11. Dismount, ground tie, walk over and roll the log down the rail, but not off
12. Return to your horse and lead out at a walk

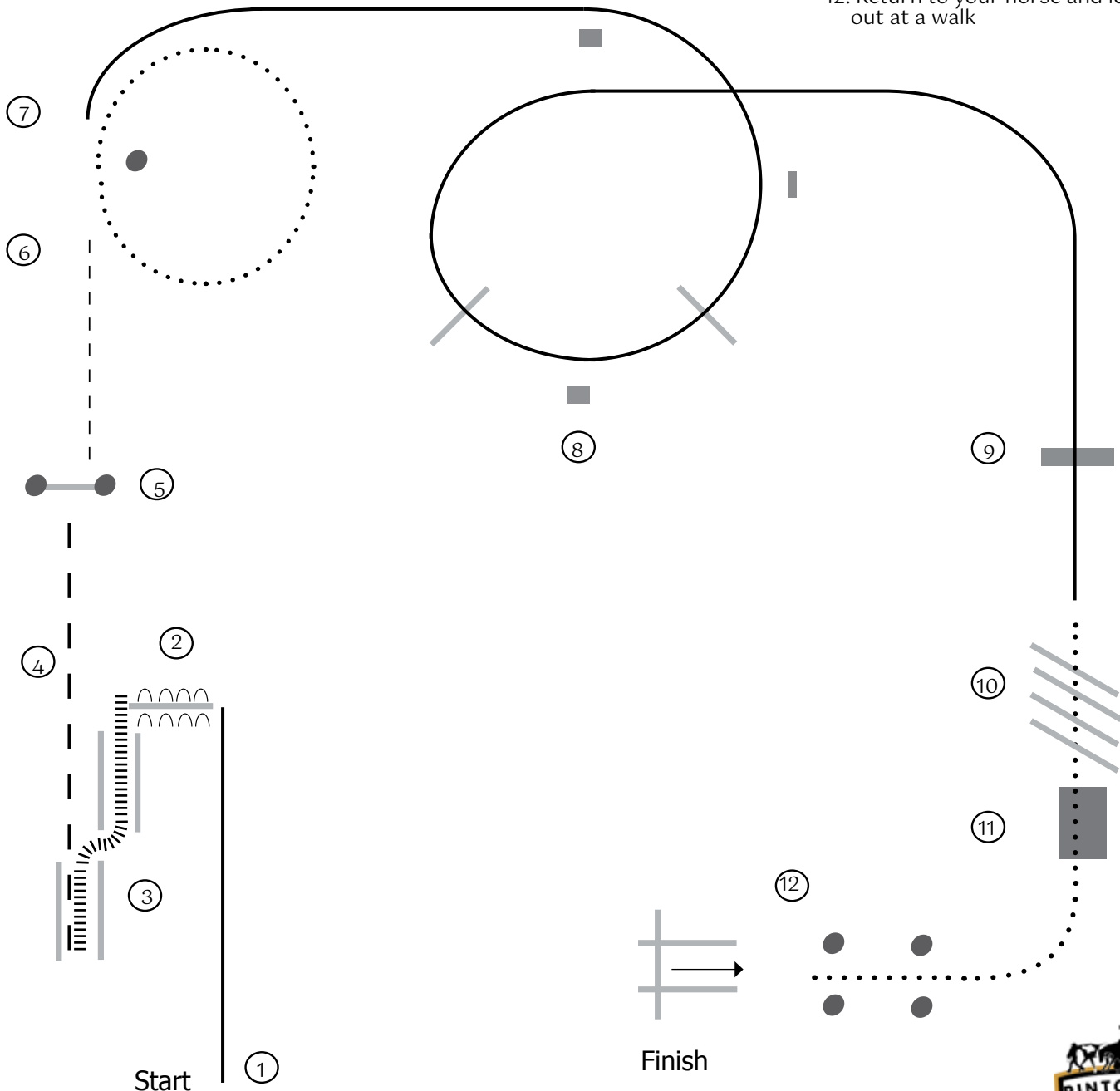

- |      |       |          |         |               |     |
|------|-------|----------|---------|---------------|-----|
| Walk | ••••• | Trot     | - - - - | Extended Trot | — — |
| Lope | —     | Sidepass | ∩∩∩∩    | Back          |     |



# Ranch Trail

## Classes

- 156 - OP - Ranch Trail, Jr. (NSBA)
- 157 - OP - Ranch Trail, Jr. Solid (NSBA)
- 158 - OP - Ranch Trail, Sr. (NSBA)
- 159 - OP - Ranch Trail, Sr. Solid (NSBA)

## Instructions

1. Lope left lead, stop
2. Sidepass left over log
3. Back through chutes
4. Extended trot to gate
5. Work gate, left hand push
6. Trot to drag, stop
7. Drag log 3/4 of the way around the circle at walk or trot, turn into your drag, back the drag to the pole and hang up the rope
8. Lope, right lead, over poles
9. Lope over jump
10. Walk over poles and bridge and to box
11. Dismount, ground tie, walk over and roll the log down the rail, but not off
12. Return to your horse and lead out at a walk

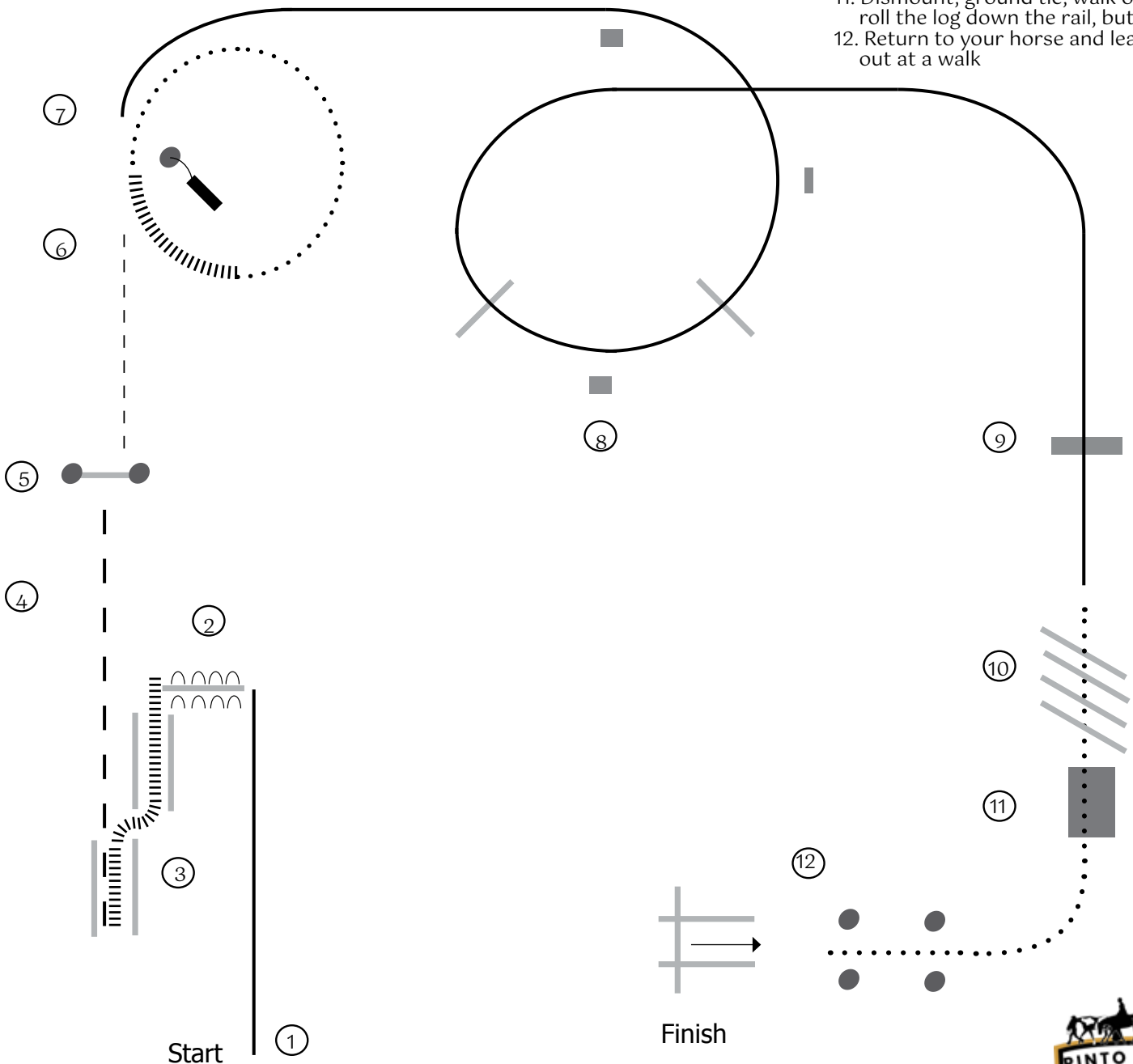

Walk .....

Trot - - - -

Extended Trot — —

Lope ————

Sidepass ^^^^

Back |||||



# Hunter Hack

## Classes

238 - AM Novice - Hunter Hack  
239 - YA Novice - Hunter Hack, Horse/Pony  
240 - OP - Hunter Hack (NSBA)  
241 - OP - Hunter Hack, Solid (NSBA)  
242 - AM - Hunter Hack (NSBA)  
243 - AM - Hunter Hack, Solid (NSBA)  
244 - YA - Hunter Hack, Horse/Pony (NSBA)  
245 - YA - Hunter Hack, Solid Horse/Pony (NSBA)

## Instructions

1. Canter over fences.
2. After 2nd fence, hand gallop to marker.
3. Stop at marker, back.

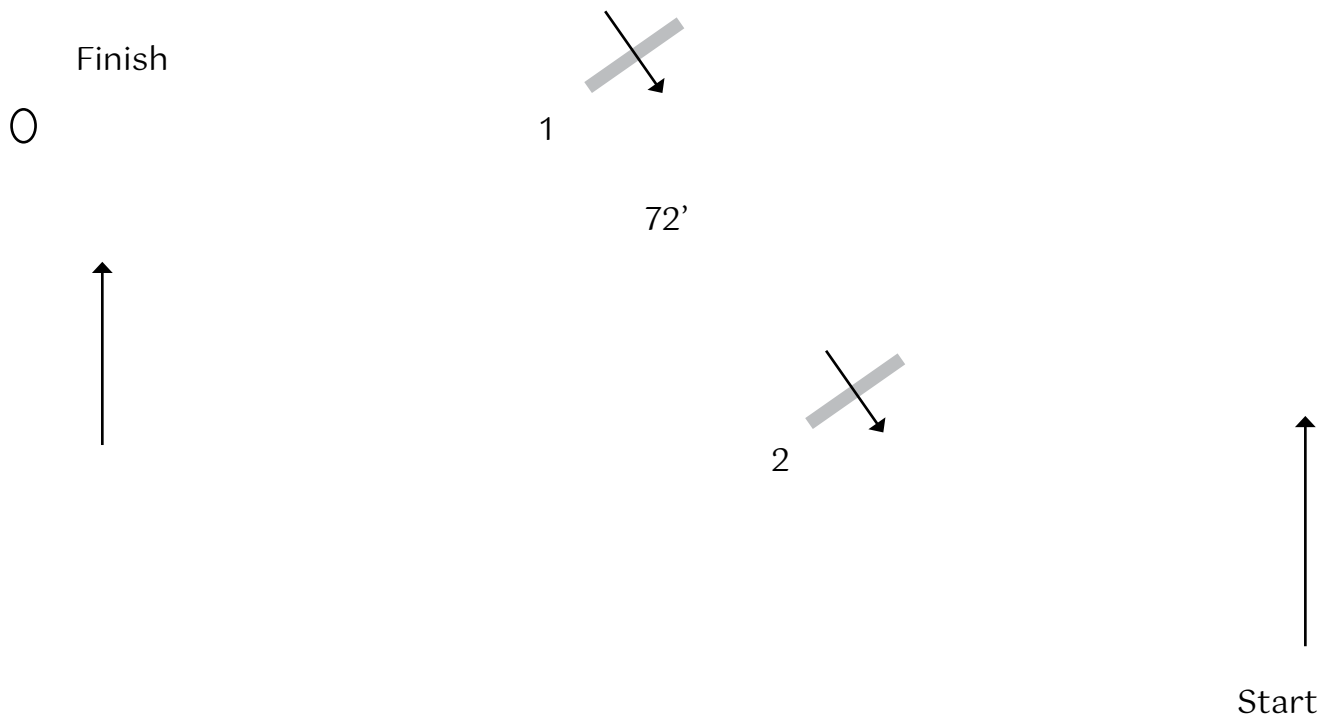

Path ———

Fence ———



# Hunter Over Fences In-Hand

Classes	Instructions
648 - OP - Hunter Over Fences In-Hand, Miniature 649 - AM - Hunter Over Fences In-Hand, Miniature/B Mini/Pony 650 - YA - Hunter Over Fences In-Hand, Miniature/B Mini/Pony 651 - OP - Hunter Over Fences In-Hand, B Mini 652 - OP - Hunter Over Fences In-Hand, Solid Miniature/B Mini 653 - OP - Hunter Over Fences In-Hand, Pony 654 - OP - Hunter Over Fences In-Hand, Solid Pony	Jump fences 1-6

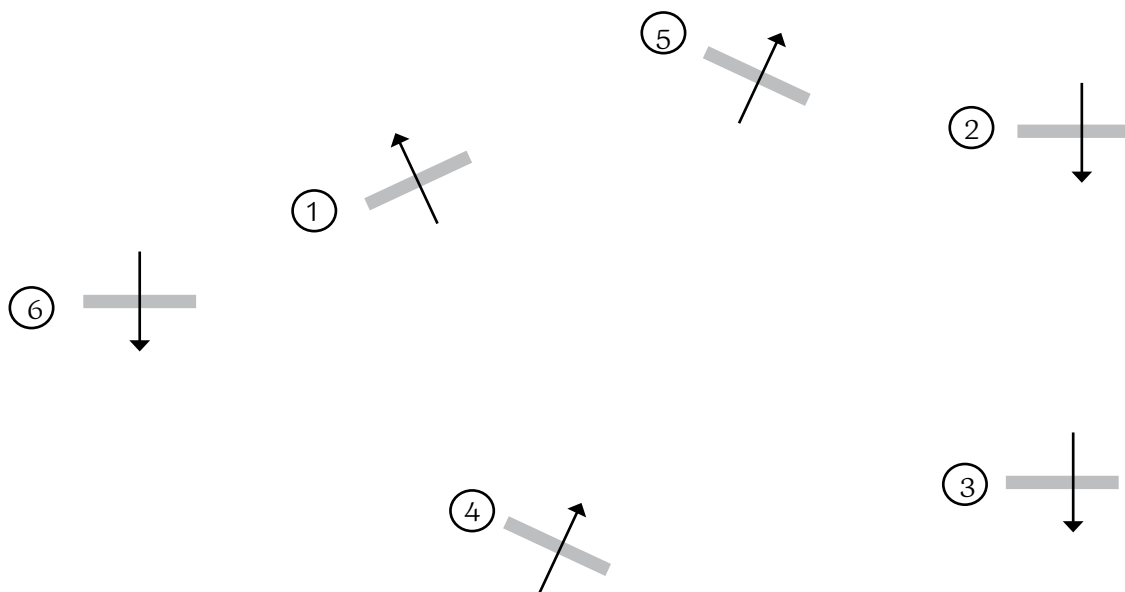

Start/Finish

Path ———

Fence ———



# Jumping In-Hand

Classes	Instructions
655 - OP - Jumping In-Hand, Miniature 656 - OP - Jumping In-Hand, B Mini 657 - OP - Jumping In-Hand, Solid Miniature/B Mini 658 - OP - Jumping In-Hand, Pony 659 - OP - Jumping In-Hand, Solid Pony 660 - AM - Jumping In-Hand, Miniature/B Mini/Pony 661 - YA - Jumping In-Hand, Miniature/B Mini/Pony	Jump fences 1-5

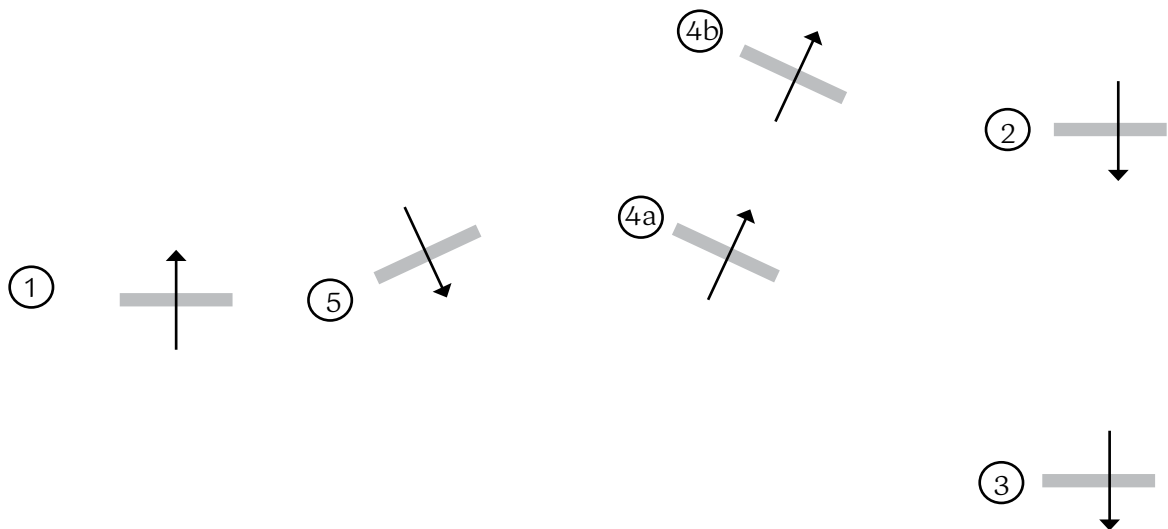

Start/Finish

Path ——— Fence ———



# Halter

Ring stewards will direct exhibitors in all halter classes. The patterns below are only meant to give exhibitors a general idea of the class procedure. After pattern is complete, ring stewards will line exhibitors up head to tail to be inspected. Exception: pleasure and saddle types will stand for inspection prior to trotting away from judges.

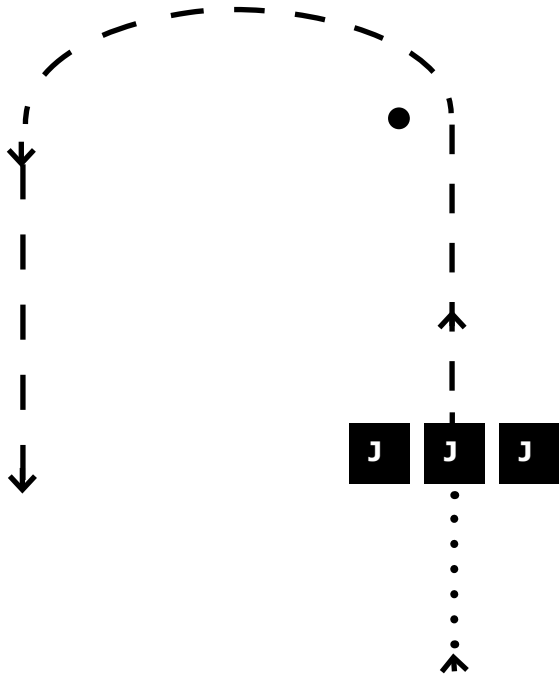

Stock Type

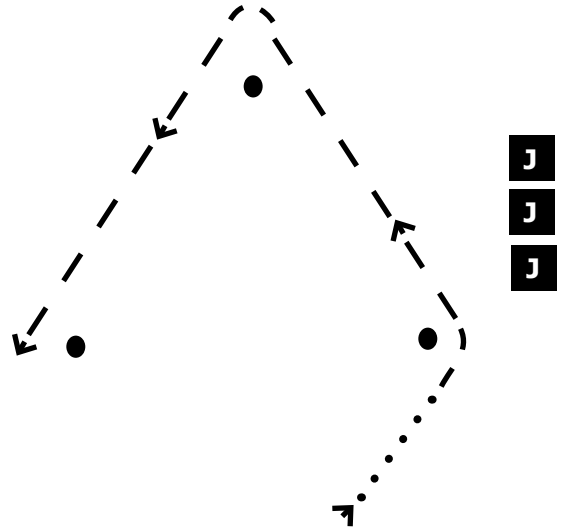

Hunter Type

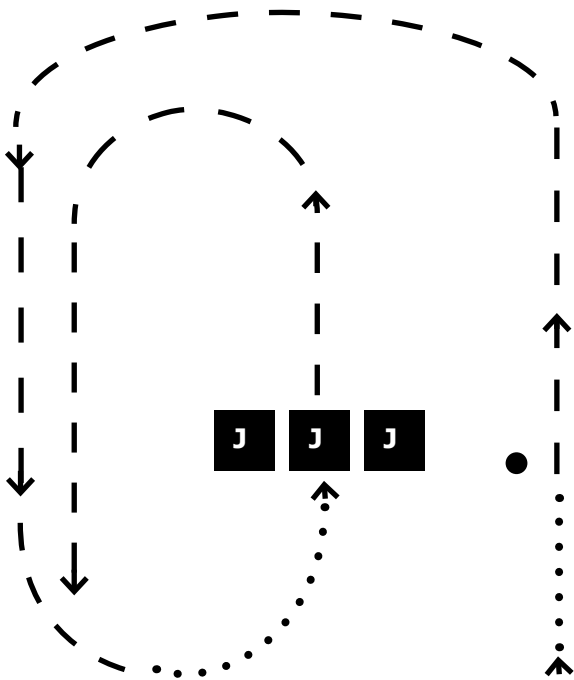

Miniature

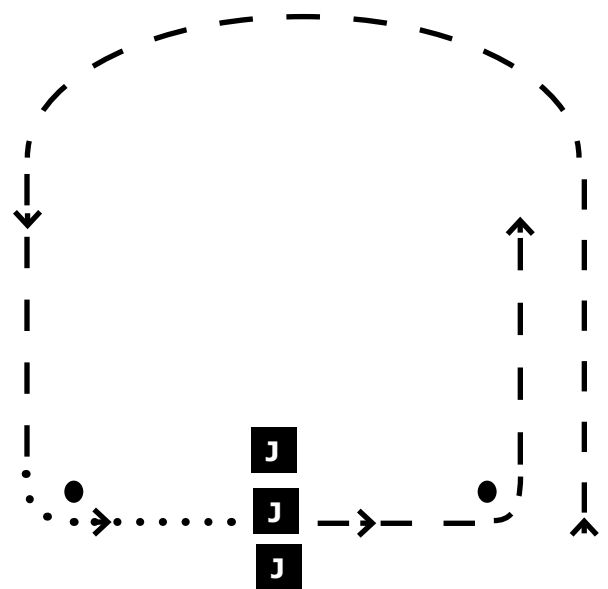

Pleasure and Saddle Type

# 2026 PINTO WORLD CHAMPIONSHIP

## PtHA.

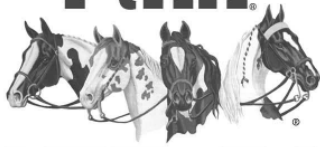

# CORPORATE PARTNERS

## DIAMOND SPUR



TULSA  
CONVENTION &  
VISITORS BUREAU

## GOLD SPUR



## RUBY SPUR



## SILVER SPUR



KELLY HERD  
FINE JEWELRY SINCE 1983



## BRONZE SPUR



## STEEL SPUR



Hodges Badge Company, Inc.  
Your **FIRST PLACE** for AWARDS®  
Family Owned & Operated Since 1920

